

TM 9-6625-2469-15

DEPARTMENT OF THE ARMY TECHNICAL MANUAL

OPERATOR'S, ORGANIZATIONAL, DIRECT SUPPORT,

GENERAL SUPPORT AND DEPOT MAINTENANCE

MANUAL [INCLUDING REPAIR PARTS]

POWER METER [HEWLETT-PACKARD MODEL 432A]

[4 9 3 1 - 4 3 6 - 4 8 8 3]

THERMISTOR MOUNT

[HEWLETT-PACKARD MODEL 478A]

[6625-866-1955]



HEADQUARTERS, DEPARTMENT OF THE ARMY

DECEMBER 1969

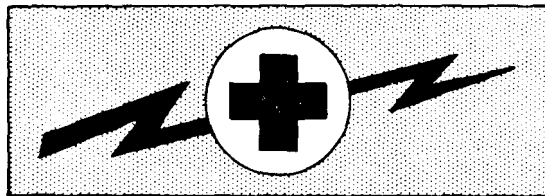

WE 20780

WARNING

HIGH VOLTAGE

is used in the operation of this equipment.

DEATH ON CONTACT

may result if personnel fail to observe safety precautions.

Learn the areas containing high voltage
in each piece of equipment.

Be careful not to contact high-voltage or 115-volt ac input connections
when installing or operating this equipment.

Before working inside the equipment, turn power off and ground points of
high potential before touching them.

POWER METER 432A

SERIAL PREFIX: 914-

This manual applies directly to HP Model 432A Power Meters having serial prefix number 914.

SERIAL PREFIXES NOT LISTED

For serial prefixes above 914, a "Manual Changes" sheet is included with this manual. For HP Model 432A with serial prefix below 914 refer to Appendix A.

(This manual contains copyright material.)

TM 9-6625-2469-15

TECHNICAL MANUAL)
)
No. 9-6625-2469-15)

HEADQUARTERS
DEPARTMENT OF THE ARMY
Washington, D.C. 22 December 1969

POWER METER (HEWLETT-PACKARD MODEL 432A)

(4931-436-4883)

THERMISTOR Mount (HEWLETT-PACKARD MODEL 478A)

(6625-866-1955)

TABLE OF CONTENTS

Section	Page	Section	Page
I GENERAL INFORMATION	1-1	V MAINTENANCE (Cont.)	
1-1. Description	1-1	5-15. Initial Setup	5-1
1-5. Instrument Identification	1-1	5-16. Meter Accuracy Test	5-1
II INSTALLATION	2-1	5-17. Calibration Factor Test	5-2
2-1. Initial Inspection	2-1	5-18. Meter Linearity Check	5-2
2-2. Mechanical Check	2-1	5-19. Zero Carryover Test	5-2
2-4. Performance Checks	2-1	5-20. Fine Zero Range Check	5-3
2-6. Damage Claims	2-1	5-21. 432 Calibration without 8477A Calibrator	5-3
2-9. Three-Conductor Power Cable	2-1	5-24. Calibration Procedure 1	5-3
2-12. Primary Power Requirements	2-1	5-26. Calibration Procedure 2	5-8
2-14. Internal Battery Operation	2-1	5-27. Cover Removal and Replacement	5-8
2-16. Battery Installation.	2-1	5-29. Top Cover Removal	5-8
2-17. Battery Storage	2-1	5-30. Top Cover Replacement	5-8
2-19. Rack Mounting	2-1	5-31. Bottom Cover Removal	5-8
2-21. Combining Case	2-1	5-32. Bottom Cover Replacement	5-8
2-23. Adapter Frames	2-2	5-33. Adjustment Procedures	5-8
2-25. Repacking for Shipment	2-2	5-34. Initial Setup	5-8
III OPERATING INFORMATION.	3-1	5-35. Mechanical Meter Adjustment	5-8
3-1. Introduction	3-1	5-36. Bridge Amplifier Tests	5-9
3-4. Controls, Connectors, and Indicators	3-1	5-37. Meter and Recorder Output Calibration	5-9
3-12. Battery Operation	3-1	5-38. Battery Charger Adjustment (Option 01 Only)	5-9
3-17. Microwave Power Measurement Accuracy	3-2	5-39. Battery Removal	5-10
3-23. Calibrator Factor and Effective Efficiency	3-2	5-40. Isolating Trouble in Transistor Circuits	5-10
3-27. Precision Power Measurement	3-2	5-46. Out-of-Circuit Testing	5-10
3-28. General	3-2	5-48. Component Replacement in Etched Circuits	5-13
3-30. Measurement Procedure	3-2	5-50. Axial-Lead Components	5-13
IV PRINCIPLES OF OPERATION	4-1	5-52. Other Components	5-13
4-1. Simplified Description	4-1	VI REPLACEABLE PARTS	6-1
4-5. Functional Block Diagram	4-1	6-1. Introduction	6-1
V MAINTENANCE	5-1	6-3. Ordering Information	6-1
5-1. Introduction	5-1	VII TROUBLESHOOTING. SCHEMATICS. AND COMPONENT TICATIONS	7-1
5-3. Content	5-1	7-1. Introduction	7-1
5-4. Performance Tests	5-1	7-5. Troubleshooting	7-1
5-6. Adjustments	5-1	7-8. Schematics	7-1
5-10. Test Equipment	5-1	7-12. AIAI Auto Zero Assembly	7-1
5-12. Service Information	5-1	7-14. Test Conditions	7-1
5-14. 432 A Performance Tests with 8477A Calibrator.	5-1		

LIST OF TABLES

Number	Title	Page	Number	Title	Page
1-1.	Specifications,	1-1	7-1.	Schematic Notes	7-2
1-2.	Thermistor Mounts for the 432A	1-2	7-2.	Overall Troubleshooting	7-5
5-1.	Recommended Test Equipment	5-0	7-3.	RF Bridge Troubleshooting	7-6
5-2.	Meter Accuracy Test	5-2	7-4.	Compensation Bridge Troubleshooting..	7-6
5-3.	Calibration Factor Test.	5-2	7-5.	Auto-Zero Troubleshooting.	7-7
5-4.	Performance Test Card.	5-5	7-6.	Chopping and Summing Circuit Troubleshooting	7-7
5-5.	Out-of-Circuit Transistor Resistance Measurements	5-11	7-7.	5 kHz Multivibrator Troubleshooting	7-7
5-6.	Etched Circuit Soldering Equipment	5-13	7-8.	Range Amplifier Troubleshooting	7-7
5-7.	Safe Ohmmeter Range for Transistor Resistance Measurements	5-13	7-9.	Calibration Factor Amplifier Troubleshooting	7-7
6-1.	Reference Designation Index	6-2	7-10.	Pulse Width Modulator and Meter Troubleshooting	7-7
6-2.	Replaceable Parts	6-12	7-11.	Power Supply Troubleshooting	7-9
6-3.	Code List of Manufacturers	6-15			

LIST OF ILLUSTRATIONS

Number	Page	Number	Page
1-1.	HP Model 432A Power Meter	1-0	
1-2.	Instrument Identification	1-1	
2-1.	Sub- module Installation in Rack Adapter Frame	2-2	
2-2.	HP Model 1051A Combining Case Instrument Installation	2-2	
3-1.	Precision Power Measurements	3-3	
3-2.	Front Panel Controls, Connectors and Indicators	3-4	
3-3.	Rear Panel Controls and Connectors	3-6	
3-4.	Turn On and Zeroing Procedure	3-8	
4-1.	Model 432A Simplified Block Diagram.	4-0	
4-2.	Model 432A Block Diagram.	4-3	
4-3.	Model 432A RF Bridge Talking Schematic.	4-4	
4-4.	Model 432A Meter Logic Talking Schematic	4-6	
4-5.	Model 432A Power Supply Talking Schematic	4-8	
5-1.	Check and Adjustment Test Setup	5-1	
5-2.	Zero Carryover Test Setup	5-3	
5-3.	Bridge Amplifier Test,	5-10	
5-4.	Transistor Biasing and Operating Characteristics	5-12	
7-1.	Servicing Block Diagram	7-3	
7-2.	Model 432A Top Internal View	7-4	
7-3.	Model 432A Waveforms	7-4	
7-4.	Model 432A Test Point Locations	7-5	
7-5.	Model 432A Bottom View, Component Locations	7-6	
7-6.	Model 432A Front Panel Interior	7-6	
7-7.	A1 Bridge Assembly, Component Locations	7-10	
7-8.	Model 432A Rear Panel Interior	7-10	
7-9.	RF and Compensation Bridge Schematic Diagram	7-11	
7-10.	Model 432A Switches	7-12	
7-11.	A2 Meter Logic Assembly, Component Locations	7-13	
7-12.	Meter Logic Schematic Diagram	7-13	
7-13.	A2 Meter Logic Assembly, Power Supply Component Locations	7-15	
7-14.	A7 Battery Charging Circuit (Option 01) Component Locations	7-15	
7-15.	Power Supply, Schematic Diagram	7-15	
7-16.	Thermistor Cable Wiring Diagram	7-16	
A1-1.	A2 Meter Logic, Component Locations	A1-2	
A1-2.	A2 Meter Logic Assembly, Power Supply, Component Locations	A1-2	
A1-3.	Meter Logic Schematic Diagram	A1-3	
 APPENDIX A. MANUAL CHANGES -----			A1-1
B. BASIC ISSUE ITEMS LIST -----			B1-1
C. MAINTENANCE ALLOCATION CHART -----			C1-1
D. REPAIR PARTS LIST -----			D1-1

THERMISTOR MOUNT 478A

TABLE OF CONTENTS

	Page		
GENERAL INFORMATION -----	8-1		
1. Introduction -----	8-1		
4. Incoming Inspection -----	8-2		
OPERATION -----	8-2		
7. Precautions -----	8-2		
8. Mechanical Shock -----	8-2		
10. Biasing Thermistors -----	8-2		
11. Minimum Input -----	8-2		
13. Average Power -----	8-2		
14. Pulse Energy and Peale Power 478A/432 -----	8-2		
15. Pulse Energy and Peak Power 478A/431 -----	8-3		
19. Drift Precaution -----	8-3		
21. Zero-Set -----	8-3		
23. RF Power Turned Off For Zero-Set -----	8-3		
25. Thermistor Mount Dis- connected For Zero- Set -----	8-4		
26. 478A/431 -----	8-4		
30. 478A/432 -----	8-4		
31. Mount Calibration Data --	8-5		
33. -Calibration Factor -----	8-5		
35. Effective Efficiency ----	8-5		
37. Calibration Data Application -----	8-5		
39. Thermoelectric Effect ---	8-5		
43. Thermoelectric Effect Error Correction 478A/431 -----	8-6		
45. Thermoelectric Error 478A/432 -----	8-5		
OPERATING PRINCIPLES -----	8-5		
47. Circuit Description -----	8-5		
52. 431-Power Meter Detection	8-6		
54. 432 Power Detection -----	8-6		
MAINTENANCE -----	8-6		
56. Mechanical Shock -----	8-6		
58. Check On Thermistor Match -----	8-6		
60. Repair -----	8-7		
71. Thermistor Assembly Re- placement Procedure ---	8-8		
75. Removal Procedure -----	8-9		
76. Installation Procedure --	8-9		

LIST OF TALBLES			
Number	Title	Page	
1	Specifications -- - -----	8-2	
2	Methods of Switching Off RF Output of Various HP Signal Generators -----	8-4	
3	Parts Furnished in Thermistor Assembly Replacement Kit, HP 00478-600-----	8-8	
List of ILLUSTRATIONS			
Number	Title	Page	
1	Maximum Power Meter Read- ing vs PRF for Pulses Shorter than 250 u s ----	8-3	
2	Maximum Power Meter Read- ings vs Duty Cycle for Pulses Longer than 250 u s -----	8-3	
3	3 Maximum Power Meter Read- ing vs Square and Sine Wave Frequency -----	8-3	
4	Source Impedance Shunting One RF Thermistor Mount -----	8-4	
5	Schematic Diagram of a Model 478A Thermistor Mount when Connected to a 431 Power Meter -----	8-5	
6	Schematic Diagram of a Model 478A Thermistor Mount when Connected to a 4,82 Power Meter ----	8-7	
7	Check on Model 478A Thermistor Resistance Match -----	8-7	
8	Thermistor Compensation ---	8-8	
9	Model 478A Thermistor Mount Assembly -----	8-9	
10	HP Model 478A Printed Circuit Assy Wiring -----	8-10	



Figure 1-1. HP Model 432A POWER METER

SECTION I GENERAL INFORMATION

1-1. DESCRIPTION.

1-2. The Hewlett-Packard Model 432A Power Meter, with HPtemperature -compensated thermistor mounts, measures RF power from 10 microwatt (-20 dBm) to 10 milliwatts (+10dBm) full scale with 1% of full scale accuracy from 10 MHz to 40 GHz. With a selector switch, the instrument normalizes the power meter reading to compensate for the Calibration Factor of a thermistor mount used for a given measurement. For portable operation, Option 01 instruments have a rechargeable nickel-cadmium battery. See Table 1-1 for complete specifications.

1-3. The Model 432A has provision for dc substitution measurements and for power meter calibration. An output is provided for recorders or digital voltmeter readout.

1-4. Accessories, Two accessories are supplied with the Model 432A Power Meter: a 7.5-foot (2290 mm) detachable power cable and a 5-foot (1520 mm) cable that connects the thermistor mount to the meter. Thermistor mounts are available but not supplied with the power meter (refer to Table 1-2). Table 1-1 lists those accessories supplied and also those available.

1-5. INSTRUMENT IDENTIFICATION.

1-6. Hewlett-Packard instruments are identified by an 8-digit serial number. The first three digits are the Serial Prefix. To properly match a manual with the instrument to which it applies, the prefix on the instrument must be the same as the prefix at the front of the manual. If the numbers are different, information is supplied either on yellow Manual Change Supplements, or in an Appendix in the Manual. If the change information is missing, contact your HP Sales Office (Sales Offices are listed at the back of the Manual).

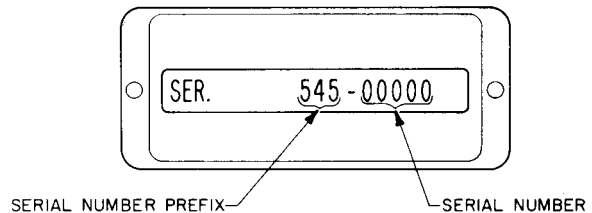

Figure 1-2. Instrument Identification

Table 1-1. Specifications

<p>Instrument Type: Automatic, self -balancing power meterforuse with temperature -compensated thermistor mount.</p> <p>Power Range: 7 ranges with full-scale readings of 10, 30, 100, and 300 μW, 1, 3 and 10 mW; also calibrated in dBm from -20 dBm to +10 dBm full scale in 5-dB steps.</p> <p>Accuracy: \pm1% of full scale on all ranges (+0°C, to +55°C).</p> <p>Calibration Factor Control: 13-position switch normalizes meter reading to account for thermistor mount Calibration Factor. Range: 100% to 88% in 1% steps.</p> <p>Thermistor Mount: External temperature -compensated thermistor mounts required for operation (see Table 1-2).</p> <p>Meter: Taut -band suspension, individually computer-calibrated, mirror-backed scales. Mini -watt scale more than 4-1/4 inches (108 mm) long.</p>	<p>Zero Carryover: Less than +0.5% of full scale when zeroed on most sensitive range.</p> <p>Fine Zero: Automatic, operated by toggle switch.</p> <p>Recorder Output: 1.000 volt into open circuit corresponds to full-scale meter deflection (I. O on O,- 1 scale) +0.5%; 1000-ohm output impedance, BNC connector.</p> <p>RFI: Meets all conditions specified in MIL-I-6181D.</p> <p>Power: 115 or 230 Vac \pm10%, 50 to 400 Hz, 2-1/2 watts. Optional rechargeable battery provides up to 20 hours continuous operation. Automatic battery recharge.</p> <p>Weight: Net 6-1/2lb(3kg), shipping 9-1/4lb(4.2kg).</p> <p>Weight with Optional Battery Pack: Net 9-1/4 lb (4.2 kg), shipping 12 lb (5.5 kg).</p>
--	--

Table 1-1. Specifications (Cont.)

Dimensions:

NOTE
 DIMENSIONS IN INCHES AND (MILLIMETERS)
 (A) FOR TOTAL LENGTH INCLUDING KNOBS
 ADD 1/4 IN. (25 MM)
 (B) FOR HEIGHT INCLUDING FEET
 ADD 7/16 IN. (11 MM)

Combining Cases:
 1051A, 11-1 4 in. (286 mm) deep.
 1052A, 16-3 8 in. (416 mm) deep.

The combining cases accept the 1 3-module HP instruments for bench use or rack mounting. See 1051A data sheet for details.

Options:
 01: Rechargeable battery installed, provides up to 24 hours continuous operation.
 02: Rear thermistor mount input connector wired in parallel with front panel input connector.
 03: Input connector placed on rear panel instead of front.

Note
 Thermistor mount cable impedance is part of the 432A input bridge circuit. For cables over 20 feet long the bridge is matched to specific cable options, so the various cables should not be interchanged.

Accessories Furnished: 5-ft (1,42 m) cable for HP temperature compensated thermistor mounts; 7-1/2 ft (2,29 m) power cable, NEMA plug.

Accessories Available:
 00415-606 Rechargeable Battery Pack for field installation.
 5060-0797 Rack Adapter Frame (holds three instruments the size of the 432A).
 8477A Power Meter Calibrator.
 11076A Carrying Case.

09: 10-foot (3,05 m) cable for 100-ohm or 200-ohm mount.
 10: 20-foot (6,10 m) cable for 100-ohm or 200-ohm mount.
 11: 50-foot (15,24 m) cable for 100-ohm or 200-ohm mount.
 12: 100-foot (30,48 m) cable for 100-ohm or 200-ohm mount.
 13: 200-foot (60,96 m) cable for 100-ohm or 200-ohm mount.

Table 1-2. Thermistor Mounts for the 432A

HP Model	Frequency Range (GHz)	Operating Resistance (Ohms)
COAXIAL MOUNTS:		
478A (Type N Connector)	0.01-10	200
8478B (Type N Connector)	0.01-18	200
8478B-Option 11 (APC-7 Connector)	0.01-18	200
WAVEGUIDE MOUNTS:		
S486A	2.6-3.95	100
G486A	3.95-5.85	100
J486A	5.3-8.2	100
H486A	7.05-10	100
X486A	8.2-12.4	100
M486A	10-15	100
P486A	12.4-18	100
K486A	18-26.5	200
R486A	26.5-40	200
WAVEGUIDE MOUNT ACCESSORIES:		
11515A: Circular Flange Adapter for K486A.		
11516A: Circular Flange Adapter for R486A.		

SECTION II

INSTALLATION

2-1. INITIAL INSPECTION.

2-2. MECHANICAL CHECK.

2-3. If damage to the shipping carton is evident, ask that the carrier's agent be present when the instrument is unpacked. Inspect the instrument for mechanical damage. Also check the cushioning material for signs of severe stress.

2-4. PERFORMANCE CHECKS.

2-5. The electrical performance of the Model 432A should be verified upon receipt. Performance checks suitable for incoming inspection are given in Section V, Maintenance.

2-6. DAMAGE CLAIMS.

2-7. If the instrument is mechanically damaged in transit, notify the carrier and the nearest Hewlett-Packard field office immediately. A list of field offices is at the back of this manual. Retain the shipping carton and padding material for the carrier's inspection. The field office will arrange for replacement or repair of your instrument without waiting for claim settlements against the carrier.

2-8. Before shipment this instrument was inspected and found free of mechanical and electrical defects. If there is any deficiency, or if electrical performance is not within specifications, notify your nearest Hewlett-Packard Sales and Service Office.

2-9. THREE-CONDUCTOR POWER CABLE.

2-10. To protect operating personnel, the National Electrical Manufacturers Association (NEMA) recommends that the instrument panel and cabinet be grounded. All Hewlett-Packard instruments are equipped with a three-conductor power cable which, when plugged into an appropriate receptacle, grounds the instrument. The offset pin on the power cable three-prong connector is the ground wire.

2-11. To preserve the protection feature when operating the instrument from a two-connector outlet, use a three-prong to two-prong adapter and connect the green pigtail on the adapter to ground.

2-12. PRIMARY POWER REQUIREMENTS.

2-13. The Model 432A operates from 115 or 230 volts ac line voltage. Line frequency may vary from 50 to 400 Hz. A slide switch on the rear panel is moved to the correct position for the line voltage available. Before operating the equipment, ensure that the fuse installed in the instrument corresponds to the value marked on the panel for the line voltage available (1/8 amp slow-blow).

2-14. INTERNAL BATTERY OPERATION.

2-15. Model 432A Option 01 instruments contain an internal battery and a battery charging assembly. By connecting the 432A to an ac source, the battery may be charged overnight. The battery can be maintained in the charging state indefinitely without damage. It will assume its full capacity, 1.25 ampere-hours, and will not charge in excess of that. This enables the instrument to operate for approximately 20 hours continuously without recharging.

2-16. BATTERY INSTALLATION.

a. Set power switch to off and remove power plug from rear panel,

b. Remove top and bottom, and side instrument covers.

c. The battery is installed with the terminals toward the right hand side of the instrument when faced from the front. The two terminals on the battery fit into spaces provided on the circuit board.

d. Using the retaining nuts, fasten the battery firmly in place. Be careful not to short the battery terminals at any time as this may cause battery cell damage.

e. Install Assembly A7, battery charging board, in the space provided for it just ahead of the battery.

f. Reinstall instrument covers and adjust circuit. Instrument is now ready for operation.

2-17. BATTERY STORAGE.

2-18. Store the battery at or below room temperature. Extended storage at high temperature will reduce the cell charge, but will not damage the battery if the storage temperature is below 140° F. Install the battery in the instrument and recharge before using Model 432A in battery operation.

2-19. RACK MOUNTING.

2-20. Model 432A is narrower than full-rack width. It is what is termed a sub-modular unit. When used alone, the instrument can be bench mounted. When used in combination with other sub-modular units it may be bench or rack mounted. The HP 1051A and 1052A Combining Cases and Rack Adapter Frames are designed specifically for this purpose.

2-21. COMBINING CASE.

2-22. A model 1051A Combining Case is shown in Figure 2-1. This case is full rack width and accepts varying combinations of submodular instruments. The case, purchased separately, is provided with a rack mounting kit. The combining case will hold three

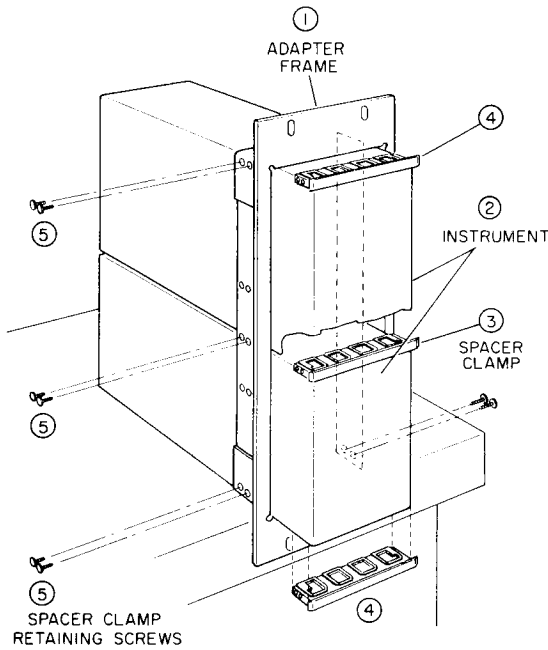

Figure 2-1. Sub -module Installation in Rack Adapter Frame

instruments the same size as the Model 432A. When instruments are installed in the combining case, they may be installed or removed individually.

2-23. ADAPTER FRAMES.

2-24. The 5060-0797 Adapter Frame is shown in Figure 2-2. The frame will accept a variety of submod - ular units in a manner suitable for rack mounting. Submodular units, in combination with any necessary spacers are assembled within the frame. A submod - ular unit cannot be removed individually.

2-25. REPACKING FOR SHIPMENT.

2-26. When returning an instrument to Hewlett-Packard use the original packing material. If the orig - inal foam type packing material is not available, contact an authorized HP Sales Office for assistance. If this is not possible, first protect the instrument sur - faces by wrapping in heavy kraft paper or with sheets of cardboard flat against the instrument. Protect the instrument on all s i d e s using approximately 4" of packing material and pack in a durable container. Mark the container clearly for proper handling and insure adequately before shipping.

2-27. When an instrument is returned to HP for service or repair, attach atagtothe instrument specifying the owner and desired action. All correspondence should identify the instrument by model number and full eight -digit serial number.

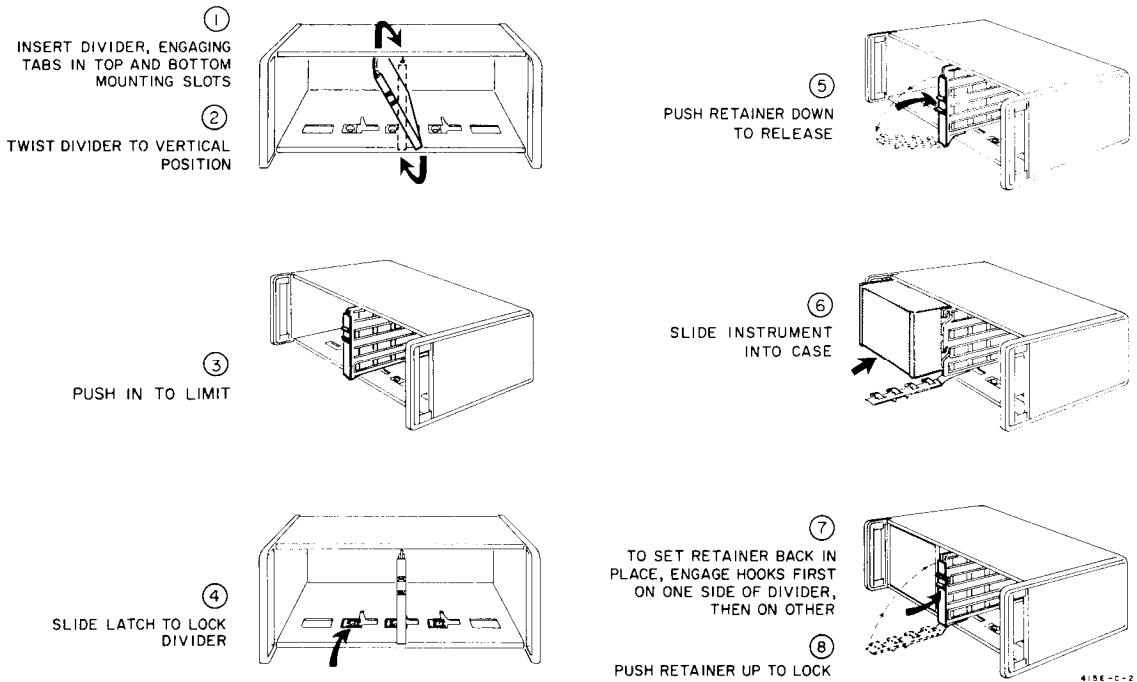

Figure 2-2. HP Model 1051A Combining Case Instrument Installation

SECTION III

OPERATING INFORMATION

3-1. INTRODUCTION.

3-2. The Model 432A Power Meter operates with HP temperature-compensated thermistor mounts such as the 8478B and 478A Coaxial, and 486A Waveguide series. The frequency range of the 432A with these mounts in 50-ohm coaxial systems is 10 MHz to 18 GHz; in waveguide systems it is 2.6 GHz to 40 GHz. Full-scale power ranges are 10 microwatts to 10milliwatts (-20 dBm to +10dBm). Extended measurements may be made to 1 microwatt (-30 dBm). The total measurement capacity of the instrument is divided into seven ranges, selected by a front-panel RANGE switch.

3-3. This section describes general operating procedures and error analysis in microwave power measurement. Application Note 64, available on request from Hewlett-Packard, is a detailed analysis of microwave power measurement problems and techniques.

3-4. CONTROLS, CONNECTORS, AND INDICATORS.

3-5. The front and rear panel controls, connectors, and indicators are explained in Figure 3-2. The descriptions are keyed to the corresponding items which are indicated on the figure.

3-6. The COARSE ZERO and FINE ZERO controls zero the meter. Zero carry-over from the most sensitive range to the other six ranges is within $\pm 0.5\%$. When the RANGE switch is set to COARSE ZERO, the meter indicates thermistor bridge unbalance, and the front panel COARSE ZERO adjust is for initial bridge balance. For best results, FINE ZERO the 432A on the particular meter range in use.

3-7. The CALIBRATION FACTOR switch provides discrete amounts of compensation for measurement uncertainties related to SWR and thermistor mount efficiency. The Calibration Factor value permits direct meter reading of the RF power delivered to an impedance equal to the characteristic impedance (Z_0) of the transmission line between the thermistor mount and the RF source. Calibration Factor values are marked on the label of each 8478B, 478A, or 486A Thermistor Mount. For further details, see Paragraph 3-23.

3-8. The MOUNT RESISTANCE switch on the front panel compensates for three types of thermistor mounts. Model 486A waveguide mounts can be used by setting the MOUNT RESISTANCE switch to 100 Ω or 200 Ω , depending on the thermistor mount used (refer to Table 1-2). The 200 Ω position is used with Models 478A and 8478B Thermistor Mounts.

3-9. The rear-panel BNC connector labeled RECORDER provides an output voltage linearly proportional to the meter current; 1 volt into an open cir-

cuit equals full-scale meter deflection. This voltage is developed across a 1K resistor; therefore, when a recorder with a 1K input impedance is connected to the RECORDER output, approximately .5 volts will equal full scale deflection. This loading of the RECORDER output has no effect on the accuracy of the 432A panel meter.

3-10. A digital voltmeter can be connected to the rear-panel RECORDER output for more resolution of power meter readings. When a voltmeter with input impedance greater than 1 megohm is connected to the RECORDER output, 1 volt equals full scale deflection.

3-11. The 432A has two calibration jacks (VRF and vcomp) on the rear panel that can be used for precision power measurements. Instrument error can be reduced from $\pm 1\%$ $\pm (0.2\%$ of reading $+5\mu\text{W})$ of reading, depending on the care taken in measurement, and on the accuracy of auxiliary equipment. For further information, see Paragraph 3-27.

3-12. BATTERY OPERATION,

3-13. The Model 432A Option 01 operates from battery and conventional 115- or 230-volt line power. A rechargeable Nickel-Cadmium battery is factory-installed in Option 01 instruments. The same battery can be ordered and later installed in the basic instrument, thereby modifying the power meter to the Option 01 configuration. The battery installation kit (including battery charging circuit) may be ordered from the nearest HP Sales Office.

3-14. It is recommended that the Model 432A be battery-operated for up to 8 hours, and then allowed to recharge 8 hours, or overnight. Continuous battery operation is possible for up to about 24 hours, but then the battery must be recharged for about 24 hours.

3-15. The 432A automatically operates on its internal batteries whenever the ac line power is disconnected and the POWER switch is ON. When the battery terminal voltage decreases far enough to force the power supply voltage regulator out of regulation, then the meter stops working and the meter indicator points to the red RECHG BAT. To recharge the battery, simply connect the 432A to ac line power, and turn it ON.

3-16. Battery Storage. Storage of the battery at or below room temperature is best. Extended storage at temperatures above room temperature will reduce cell charge, but will not damage the battery; however, the battery should not be stored where the temperature exceeds 60° C (+140° F).

3-17. MICROWAVE POWER MEASUREMENT ACCURACY.

3-18. A number of factors affect the overall accuracy of power measurement. The major sources of error are mismatch error, RF losses, and instrumentation error.

3-19. Mismatch Error. In a practical measurement situation, both the source and thermistor mount have SWR, and the source is seldom matched to the thermistor mount unless a tuner is used. The amount of mismatch loss in any measurement depends on the total SWR present. The impedance that the source sees is determined by the actual thermistor mount impedance, the electrical length of the line, and the characteristic impedance of the line, Z_0 .

3-20. In general, neither the source nor the thermistor mount has Z_0 impedance, and the actual impedances are known only as reflection coefficients, mismatch losses, or SWR. The power delivered to the thermistor mount - and hence the mismatch loss - can only be described as being somewhere between two limits. The uncertainty of power measurement due to mismatch loss increases with SWR. Limits of mismatch loss are generally determined by means of a chart such as the Mismatch Loss Limits charts in Application Note 64. The total mismatch loss uncertainty in power measurement is determined by algebraically adding the thermistor mount losses to the uncertainty caused by source and thermistor mount mismatch.

3-21. RF Losses. RF losses account for the power entering the thermistor mount but not dissipated in the detection thermistor element. Such losses may be in the walls of a waveguide mount, the center conductor of a coaxial mount, capacitor dielectric, poor connections within the mount, or due to radiation.

3-22. Instrumentation Error. The degree of inability of the instrument to measure the substitution power supplied to the thermistor mount is called power meter accuracy or instrumentation error. Instrumentation error of the Model 432A is $\pm 1\%$ of full scale, 0°C to $+55^\circ\text{C}$.

3-23. CALIBRATION FACTOR AND EFFECTIVE EFFICIENCY.

3-24. Calibration factor and effective efficiency are correction factors for improving power measurement accuracy. Both factors are marked on every HP thermistor mount. Calibration factor compensates for thermistor mount VSWR and RF losses whenever the thermistor mount is connected to an RF source without a tuner. Effective efficiency compensates for thermistor mount RF losses when a tuner is used in the measurement system.

3-25. When the 432A CALIBRATION FACTOR selector is set to the appropriate factor indicated on the thermistor mount, the power indicated by the meter is the power that would be delivered by the source to

a load impedance equal to Z_0 . More accurately, the relationship between indicated power and the power available to a Z_L load is given by the following equation:

$$P_o = \frac{P \text{ indicated } (1 \pm \rho_s \rho_m)^2}{\text{Calibration Factor}}$$

where

P_o = power available to a Z_0 load

ρ_s = source reflection coefficient

ρ_m = thermistor mount reflection coefficient

$$\rho = \frac{\text{SWR} - 1}{\text{SWR} + 1}$$

Calibration factor does not compensate for source VSWR, or for multiple reflections between the source and the thermistor mount.

3-26. To minimize mismatch between the source and the thermistor mount without a tuner, insert a low SWR precision attenuator in the transmission line between the thermistor mount and the source. Since the mount impedance (and corresponding SWR) deviates significantly only at the high and low ends of a microwave band, it is generally unnecessary to use a tuner. A tuner or other effective means of reducing mismatch error is recommended when the source SWR is high or when more accuracy is required. For further details, there is a complete discussion of microwave power measurement with emphasis on modern techniques, accuracy considerations and sources of error available in Application Note 64.

3-27. PRECISION POWER MEASUREMENT.

3-28. GENERAL.

3-29. Using precision instruments and careful procedures, measurement error can be reduced to $\pm 0.2\%$ of reading $+0.5 \mu\text{W}$. The technique involves: 1) zeroing the bridge circuits and measuring the bridge amplifier output voltage difference with a digital voltmeter, then 2) connecting RF power to the thermistor mount and then measuring the bridge amplifier output voltage difference again, and 3) calculating the power from the two measurements. Figure 3-1 shows the instrument setup for dc substitution measurement. Use an HP Model 3440A DVM, with a 3443A Plug-in Unit or a digital voltmeter with equivalent accuracy,

3-30. MEASUREMENT PROCEDURE.

a. Connect the DVM to the 432A rear panel Vcomp and VRF outputs. Be sure that the digital voltmeter input is isolated from chassis ground,

b. Turn off, or disconnect the RF power from the thermistor mount.

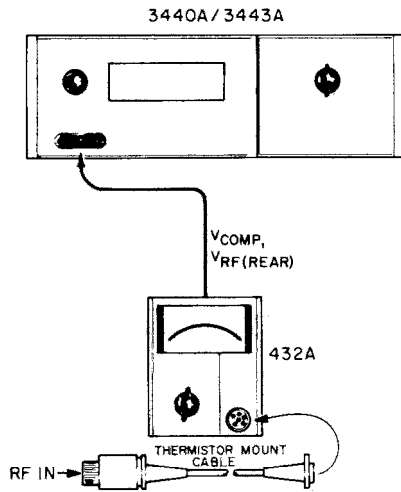

Figure 3-1. Precision Power Measurements

- c. Zero the 432A with the COARSE ZERO controls.
- d. Depress the FINE ZERO toggle, and measure the differential voltage (V_0) between V_{comp} and V_{RF} .

$$V_0 = V_{COMP} - V_{RF}$$

- e. Release the FINE ZERO toggle, and turn on, or reconnect the RF power to the thermistor mount.

- f. Measure again the differential voltage (V_1) between V_{RF} and V_{COMP} .

$$V_1 = V_{COMP} - V_{RF}$$

- g. Measure V_{COMP} to ground.

- h. Calculate incident RF power from the equation

$$P_{RF} = \frac{1}{4R} \frac{2V_{COMP}(V_1 - V_0) + V_0^2 - V_1^2}{\text{EFFECTIVE EFFICIENCY}}$$

where

R is the thermistor mount resistance.

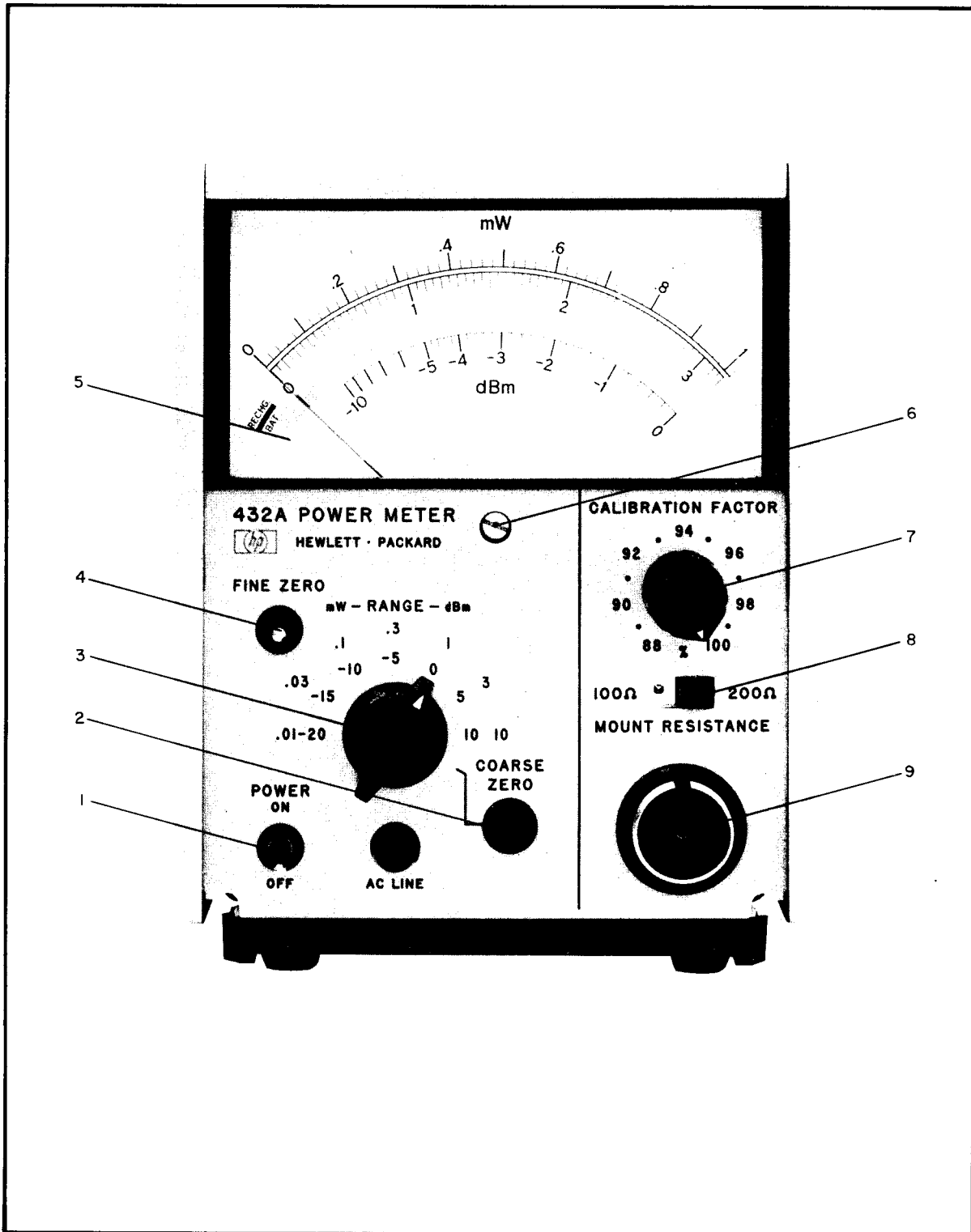

Figure 3-2. Front Panel Controls, Connectors and Indicators (Sheet 1 of 2)

1. **POWER.** Instrument power ON/OFF switch; connects either ac line voltage or internal battery (Option 01 only) to internal voltage regulator circuits. When ac power is on, optional battery charging circuit operates.
2. **COARSE ZERO.** Meter zero adjustment; set the RANGE selector to COARSE ZERO, turn OFF the RF power, and adjust to zero the meter.
3. **RANGE.** Power measurement range selector; selects ranges from 0.01 to 10 milliwatts (-20 to +10dBm). COARSE ZERO setting is used to zero meter with no power applied to thermistor mount.
4. **FINE ZERO.** Electronic zero that balances the compensation bridge with zero RF input. To zero meter during operation, close the switch momentarily. Be sure that RF power is not applied to the thermistor mount when the FINE ZERO switch is depressed.
5. **Meter.** Indicates power input to thermistor mount in milliwatts and dBm. To use the dBm scale, note the value in dBm of the range in use, and subtract from it the reading on the meter dBm scale.
6. **Mechanical Meter Zero.** Sets meter suspension so that meter indicates zero. To adjust the zero:
 - a. Turn POWER switch off.
 - b. Turn the adjustment screw clockwise until the indicator falls below zero and comes back up to zero again.
 - c. Turn the adjustment very slightly counterclockwise to free up the mechanism from the adjusting peg.
7. **CALIBRATION FACTOR.** Amplifier gain compensation selector. Set to correspond to the calibration factor printed on the thermistor mount body. See Paragraph 3-23 for more information.
8. **MOUNT RESISTANCE.** Selects resistance equal to that of mount in use to balance bridges. Table 1-2 lists Hewlett-Packard thermistor mounts and resistances. Set with meter power OFF, when mount is initially connected to the meter.
9. **Thermistor Mount Cable Connector.** Input connector for 5-1/2 foot cable that connects to the 478A, 8478B, or 486A Thermistor Mounts.

Figure 3-2. Front Panel Controls, Connectors and Indicators (Sheet 2 of 2)

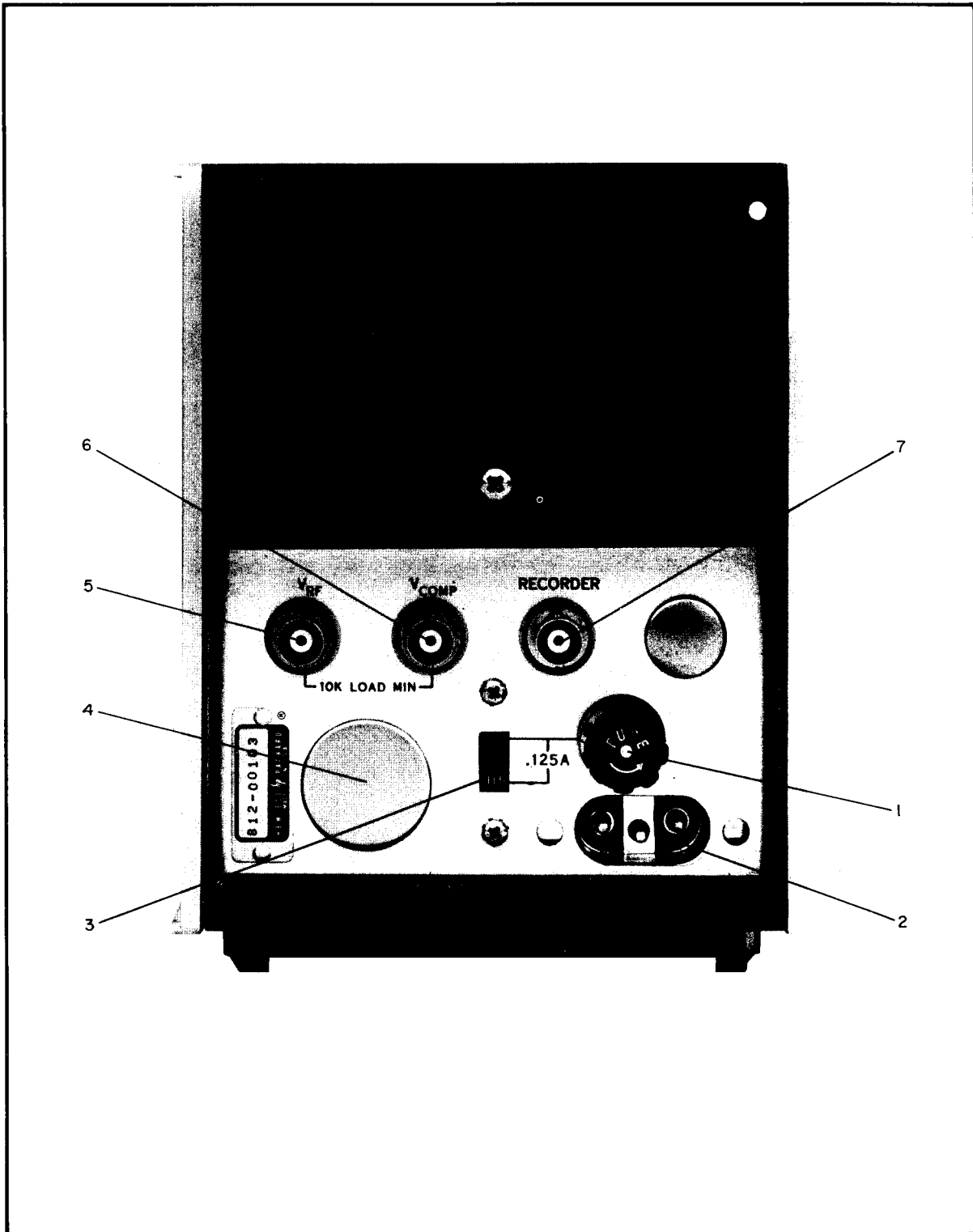

Figure 3-3. Rear Panel Controls and Connectors (Sheet 1 of 2)

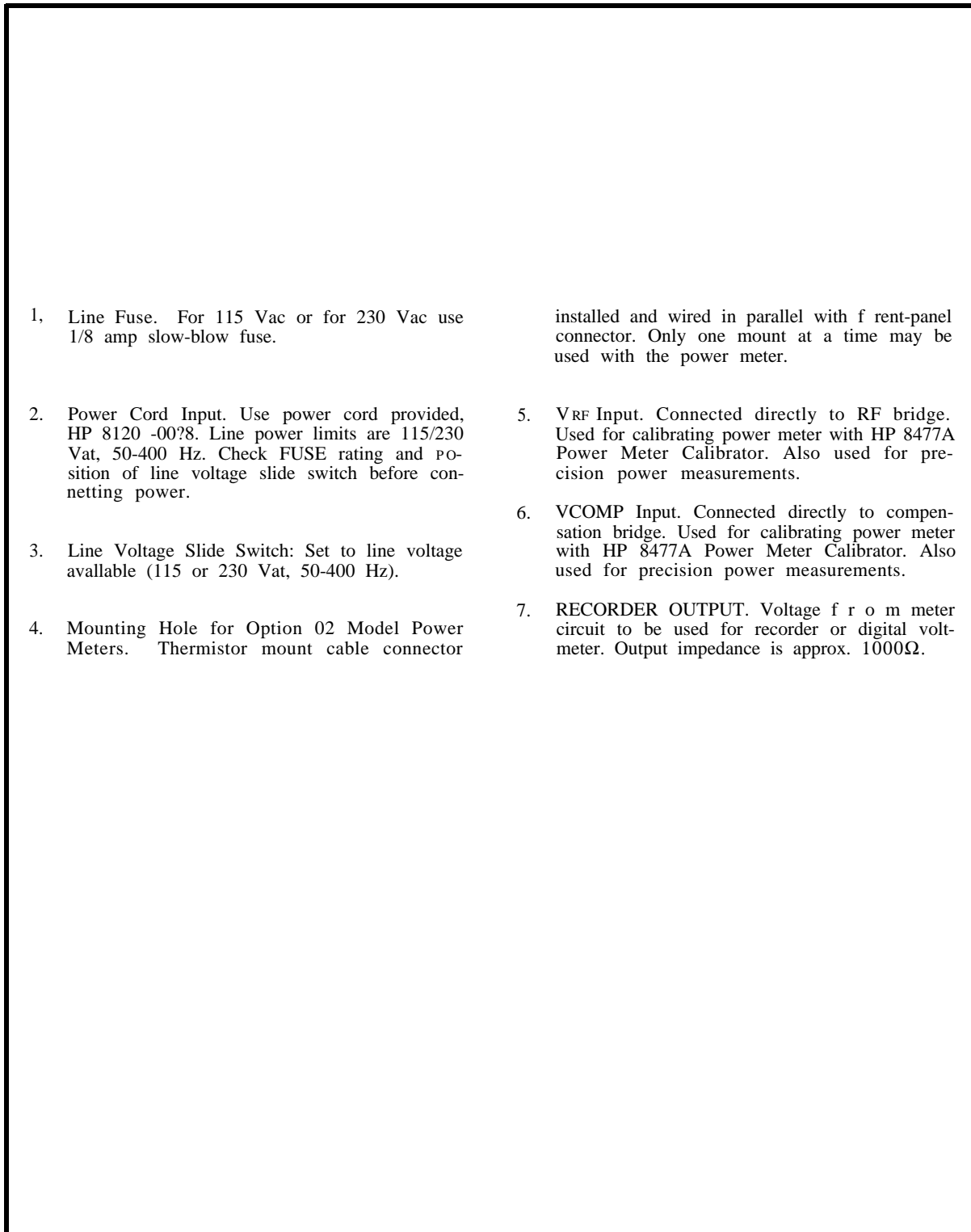

Figure 3-3. Rear Panel Controls and Connectors (Sheet 2 of 2)

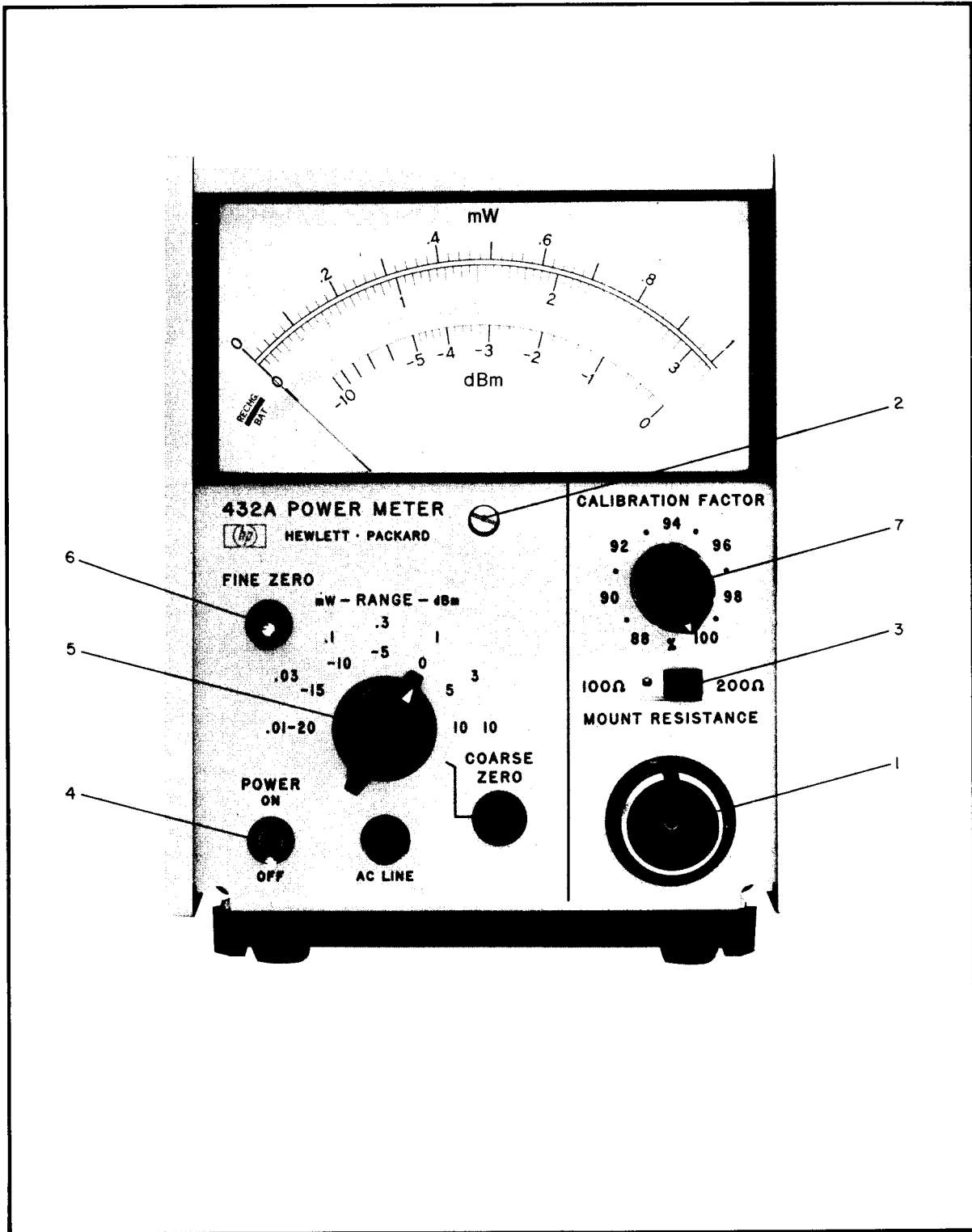

Figure 3-4. Turn On and Zeroing Procedure (Sheet 1 of 2)

1. Connect the thermistor mount and cable to THERMISTOR MOUNT connector. Refer to Table 1-2 for recommended thermistor mounts and their frequency ranges.
2. Meter Mechanical Zero:
 - a. With the instrument turned off, rotate the meter adjustment screw clockwise until the pointer approaches the zero mark from the left.
 - b. Continue the clockwise rotation until the pointer coincides with the zero mark. If the pointer overshoots, continue rotating the adjustment screw clockwise until the pointer once again approaches the zero mark from the left.
 - c. Rotate the adjustment screw about three degrees counterclockwise to disengage screw adjustment from the meter suspension.
3. Set the MOUNT RES switch to correspond to the operating resistance of thermistor mount used.
4. Turn the 432A POWER switch ON. For battery operation, the AC LINE indicator does not turn on.
5. Set the RANGE selector to COARSE ZERO and then zero the meter with the COARSE ZERO screwdriver adjustment.

Note

The power meter should be zeroed with the RF power source turned off, or the mount disconnected from the source.
6. Set the range selector to the 0.01 mW range; then depress the FINE ZERO switch until the meter indicates zero.

Note

Range-to-range zero carryover is less than $\pm 0.5\%$ if the meter zero has been adjusted (step 2 above), and the instrument has been properly zero-set on the sensitive range. For maximum accuracy, zero-set the power meter on the range to be used.
7. Set CALIB FACTOR switch to correspond to Calibration Factor imprinted on HP thermistor mount label.
8. Apply RF power to the thermistor mount. Power is indicated on the meter directly in mW or dBm.

Figure 3-4. Turn On and Zeroing Procedure

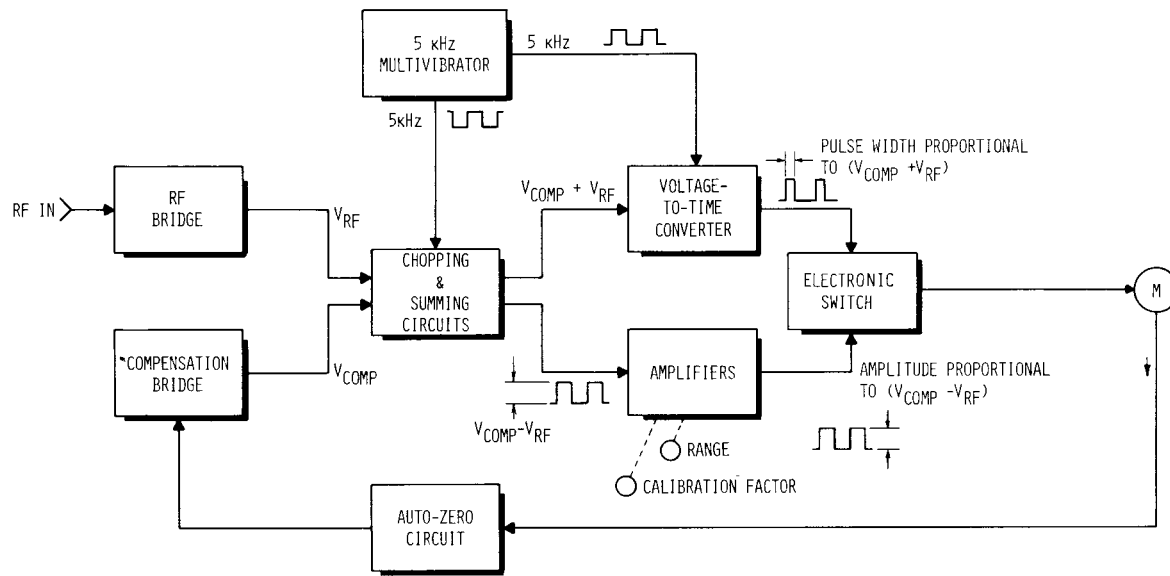

Figure 4-1. Simplified 432A Block Diagram

SECTION IV

PRINCIPLES OF OPERATION

4-1. SIMPLIFIED DESCRIPTION

4-2. The HP 432A Power Meter consists of two major sections: the bridge and meter logic assemblies. The instrument also contains an auto zero circuit which provides for automatic zeroing on any range. A simplified Mock diagram of the HP 432A is shown in Figure 4-1.

4-3. The bridge section contains circuits which form two self-balancing bridge circuits when a suitable thermistor mount is connected to the 432A. Each bridge is automatically brought to balance by the action of a high gain dc amplifier feeding power to the top of the bridge. The voltage at the top of the RF bridge V_{RF} is responsive to both input RF power and ambient temperature changes. The voltage at the top of the compensation bridge, V_{COMP} is responsive only to ambient temperature changes. Knowing V_{RF} and V_{COMP} , the RF power can be calculated.

4-4. The meter logic section processes V_{RF} and V_{COMP} to produce a meter current proportional to RF power. The sum ($V_{RF} + V_{COMP}$) controls the width of 5 kHz pulses. The difference ($V_{COMP} - V_{RF}$) is chopped, amplified and fed to an electronic switch actuated by the controlled width pulses. Therefore, the meter current is pulses of variable height and width with the meter indicating the average current. (This process produces a meter current proportional to $(V_{RF} + V_{COMP})(V_{RF} - V_{COMP})$. Paragraph 4-10 explains why this is necessary.

4-5. FUNCTIONAL BLOCK DIAGRAM

4-6. A functional block of the 432A power meter is shown in Figure 4-2. The instrument comprises two major assemblies: bridge assembly A1 and meter logic assembly A2. Auto zero circuit A1, which provides for automatic zeroing of the instrument, is included as part of logic assembly A1.

4-7. The thermistor bridges are biased with direct current from the bridge amplifiers. Each bridge amplifier supplies enough heating current to bring the thermistor resistance to 100 or 200 ohms, depending upon the setting of the MOUNT RESISTANCE switch on the 432A. If one of the thermistor bridges is unbalanced due to incorrect thermistor resistance, an error voltage occurs and is amplified by the bridge amplifier. The error voltage is applied to the top of the bridge and changes the power dissipation of the negative temperature coefficient thermistor. The change of power dissipation causes the resistance to the thermistor to change in the direction required to balance the bridge. Application of RF power to the RF bridge heats the thermistor and lowers its resistance. The bridge circuit responds by reducing the dc voltage applied to the top of the bridge thus maintaining bridge balance.

4-8. If ambient temperature causes changes in the thermistor resistance, the bridge circuits respond by applying an error voltage to the bridges to maintain bridge balance. The voltage at the top of the RF bridge is dependent upon both ambient temperature and the RF input. The voltage at the top of the compensation bridge is dependent upon the ambient temperature only. The power meter reading is brought to zero with no applied RF power by making V_{COMP} equal to V_{RF} so ($V_{COMP} - V_{RF}$) equals zero. Since ambient temperature causes both thermistors to respond similarly, there will be no net difference between the amplifier output voltages. Therefore, any difference in output voltages from the bridges is now due to RF power absorbed by the thermistor mount.

4-9. The RF bridge voltage, V_{RF} , and the compensation bridge voltage, V_{COMP} , contain the "RF power" information. To provide a meter reading proportional to RF power the dc voltages (V_{RF} , V_{COMP}) must be further processed by the meter logic circuits.

4-10. The required processing is derived as follows: P_0 is absorbed power needed by the RF thermistor to bring its resistance to R ohms (100 or 200 ohms). P_0 consists of two components: RF power from the signal source to be measured and dc power supplied by the 432A. The self balancing action of the bridge circuit automatically adjusts the dc power so that the total power in the thermistor is P_0 . This dc power is related to the voltage V_{RF} at the top of the bridge by $(V_{RF}/2)^2/R$. Thus

$$\begin{aligned} P_0 &= \text{RF power} + \text{DC power} \\ &= \text{RF power} + \frac{V_{RF}^2}{4R} \end{aligned}$$

4-11. RF power can be redetermined by measuring V_{RF} with and without applied RF power and then doing some arithmetic. But this power measuring scheme is neither convenient nor temperature compensated (since P_0 changes with temperature). The 432A introduces another thermistor bridge circuit exposed to the same ambient temperature but not RF power. This circuit includes adjustments (COARSE and FINE ZERO) so that the dc voltage V_{COMP} at the top of its bridge can be set equal to V_{RF} . Assuming matched RF and compensation thermistors, V_{RF_0} (with no RF power) and V_{COMP} remain equal with ambient temperature fluctuation. They differ only when the RF power to be measured is applied to the RF thermistor. Thus, we have

$$\begin{aligned} V_{COMP} &= V_{RF_0} \quad \text{when RF power} = 0 \\ \text{and} \\ P_0 &= 0 + \frac{V_{COMP}^2}{4R} \end{aligned}$$

Combining equations, we have

$$\frac{V_{\text{COMP}}^2}{4R} = \text{RF power} + \frac{V_{\text{RF}}^2}{4R}$$

or

$$\begin{aligned} \text{RF power} &= \frac{V_{\text{COMP}}^2 - V_{\text{RF}}^2}{4R} \\ &= \frac{1}{4R} (V_{\text{COMP}} + V_{\text{RF}})(V_{\text{COMP}} - V_{\text{RF}}) \end{aligned}$$

4-12. Thus an RF power measurement reduces to setting $V_{\text{COMP}} = V_{\text{RF}_0}$ (with zero RF power) initially,

measuring V_{COMP} and V_{RF} , and computing with the above formula. The 432A carries out the computation by forming the indicated sum and difference, performing the multiplication and displaying the result on a meter.

4-13. The meter logic circuits change the two dc voltages to two pulse signals which contain all the RF power information. One of the signals will be a square wave whose amplitude is proportional to $V_{\text{COMP}} - V_{\text{RF}}$. The other signal will have a pulse width proportional to $V_{\text{COMP}} + V_{\text{RF}}$.

4-14. The $V_{\text{COMP}} - V_{\text{RF}}$ signal is obtained by taking the dc voltage outputs from the AI assembly and applying them to a chopper circuit. This chopper circuit is driven by a 5-kHz multivibrator. The output of the chopper is a square wave signal whose amplitude is proportional to $V_{\text{COMP}} - V_{\text{RF}}$. The output of the chopper is coupled to the range amplifier and then to the calibration factor amplifier. The amplification that the signal receives in these two amplifiers depends upon the setting of the RANGE switch and the CALIBRATION FACTOR switch. The output of the calibration factor amplifier is V . This current is fed to the electronic switch. A square wave current with amplitude proportional to $(V_{\text{COMP}} - V_{\text{RF}})$.

4-15. The $V_{\text{COMP}} + V_{\text{RF}}$ signal is obtained by taking the two dc voltages from AI assembly through a summing circuit and feeding this voltage to a voltage-to-time converter. The voltage-to-time converter is driven by a 5-kHz multivibrator. The output of the voltage-to-time converter is a signal whose pulse width is proportional to the sum of $V_{\text{COMP}} + V_{\text{RF}}$. This signal controls the electronic switch. From the $V_{\text{COMP}} - V_{\text{RF}}$ and $V_{\text{COMP}} + V_{\text{RF}}$ inputs, the electronic switch provides a 5-kHz pulse train whose amplitude is proportional to $V_{\text{COMP}} - V_{\text{RF}}$ and whose pulse width is proportional to $V_{\text{COMP}} + V_{\text{RF}}$. The pulse width is always 90 msec or less.

4-16. The bias circuit switch and filter provides a zero current reference for the meter circuit. This is accomplished by controlling the dc bias to the first stage of the calibration factor amplifier. This circuit, in effect, restores the dc component to the square wave which has been amplified by ac coupled amplifiers.

4-17. The meter is 0-1 mA, full-scale meter that has a capacitor across its terminals. The capacitor integrates the output pulses from the current switch so the current into the meter is proportional to the time average of the input pulses. That is, the input current to the meter is proportional to the product of

$$(V_{\text{COMP}} + V_{\text{RF}})(V_{\text{COMP}} - V_{\text{RF}}) = (V_{\text{COMP}})^2 - (V_{\text{RF}})^2.$$

4-18. The output from the meter is further filtered so the voltage at the rear panel RECORDER output is suitable for use with either a digital voltmeter or X-Y recorder. The RECORDER output voltage is returned to the compensation bridge through the automatic zero circuit when the FINE ZERO switch is depressed. The automatic zero circuit holds a correction voltage at the input of the compensation bridge amplifier, so when the RF is zero, the meter indication will also be zero.

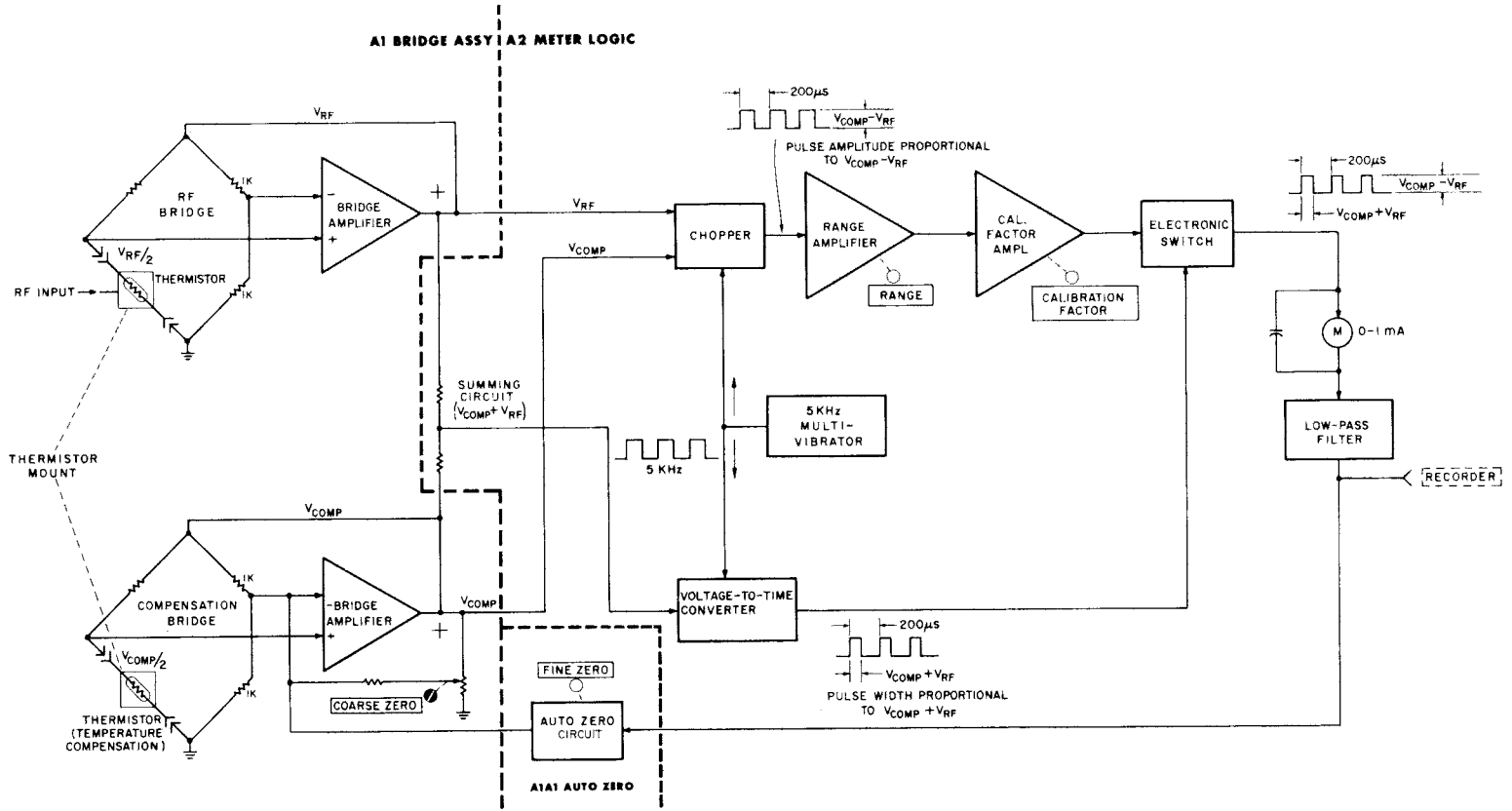

Figure 4-2. Model 432A Block Diagram

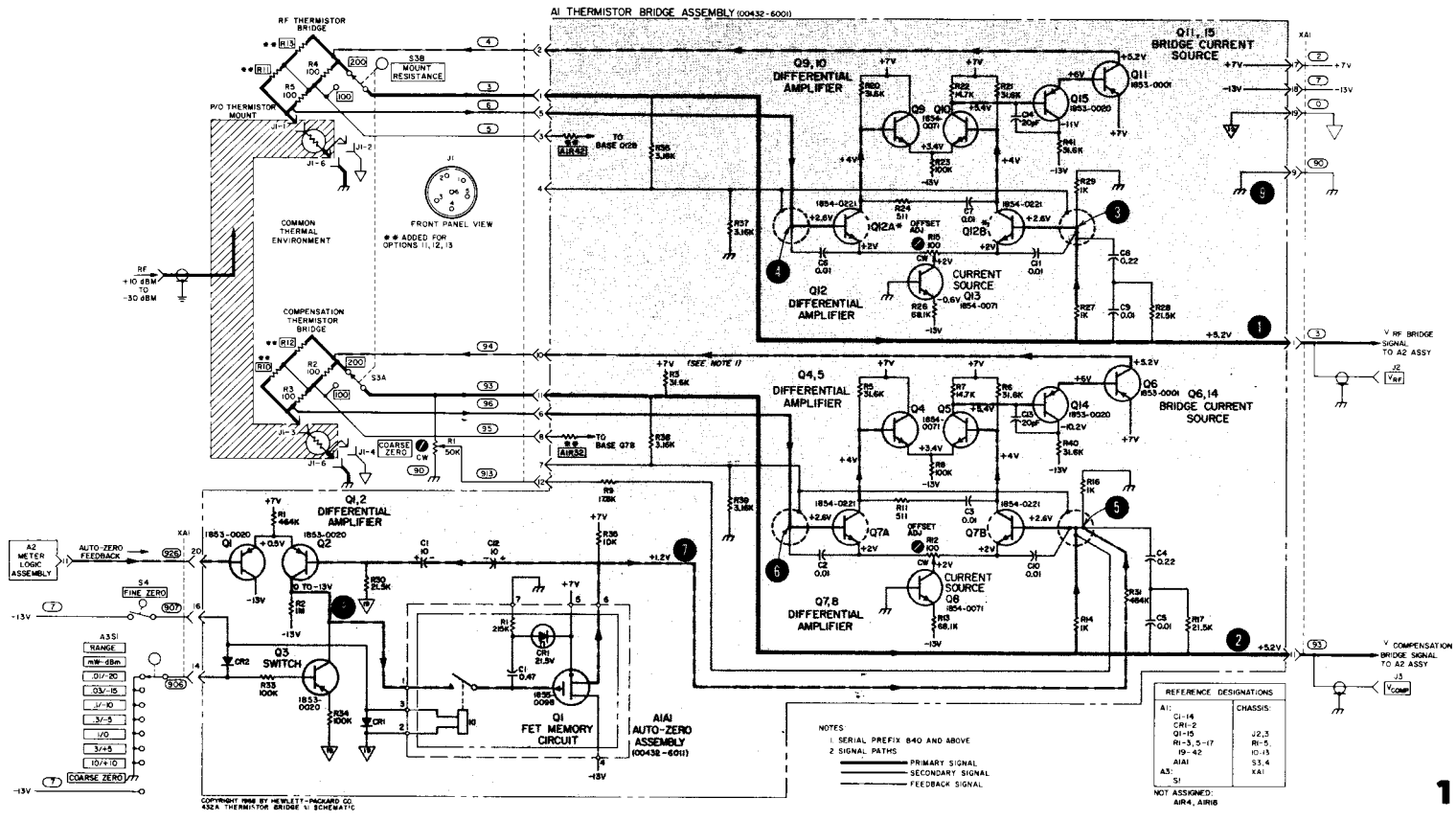

Figure 4-3. Model 432A RF Bridge Talking Schematic (Sheet 1 of 2)

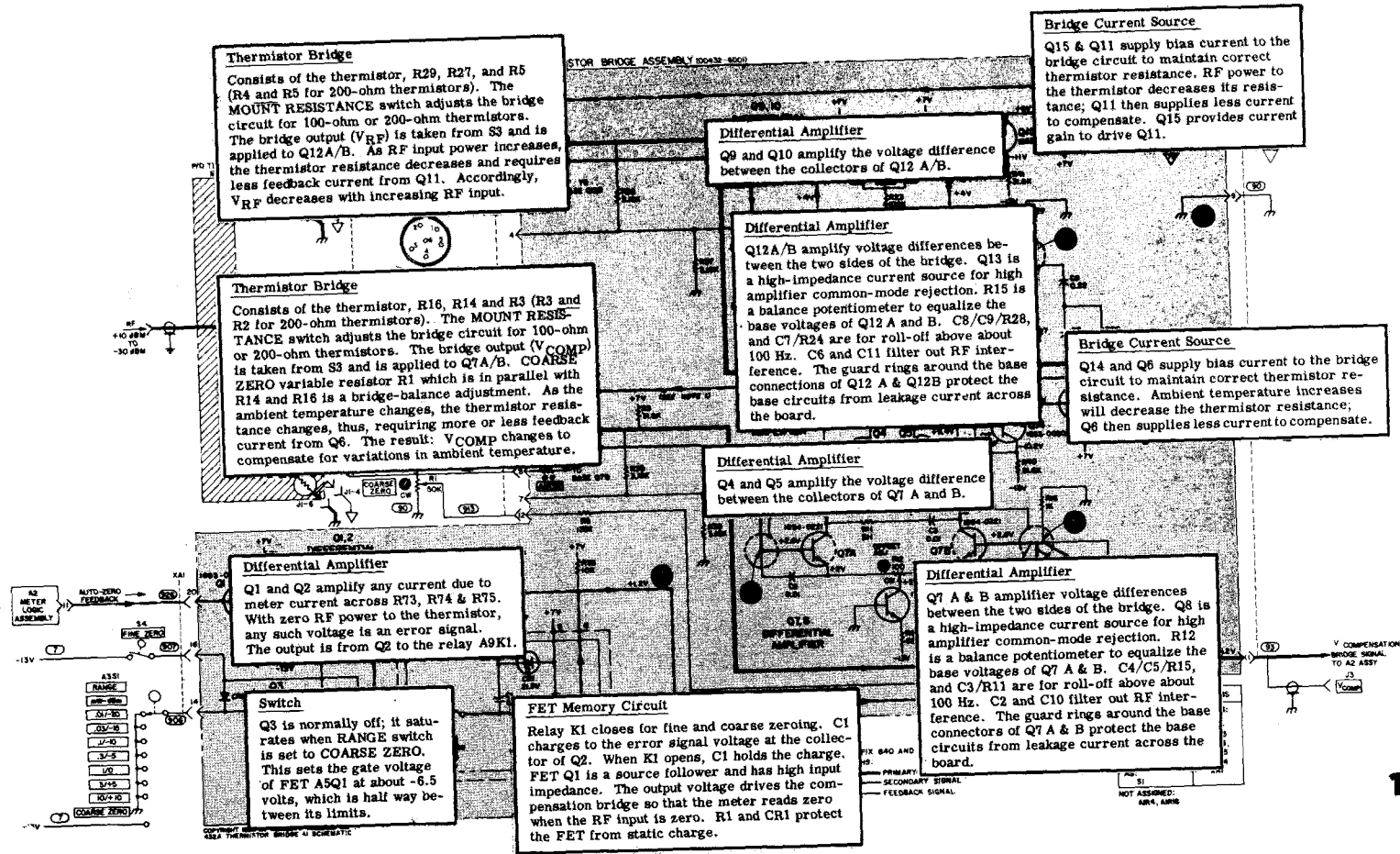

Figure 4-3. Model 432A RF Bridge Talking Schematic (Sheet 2 of 2)

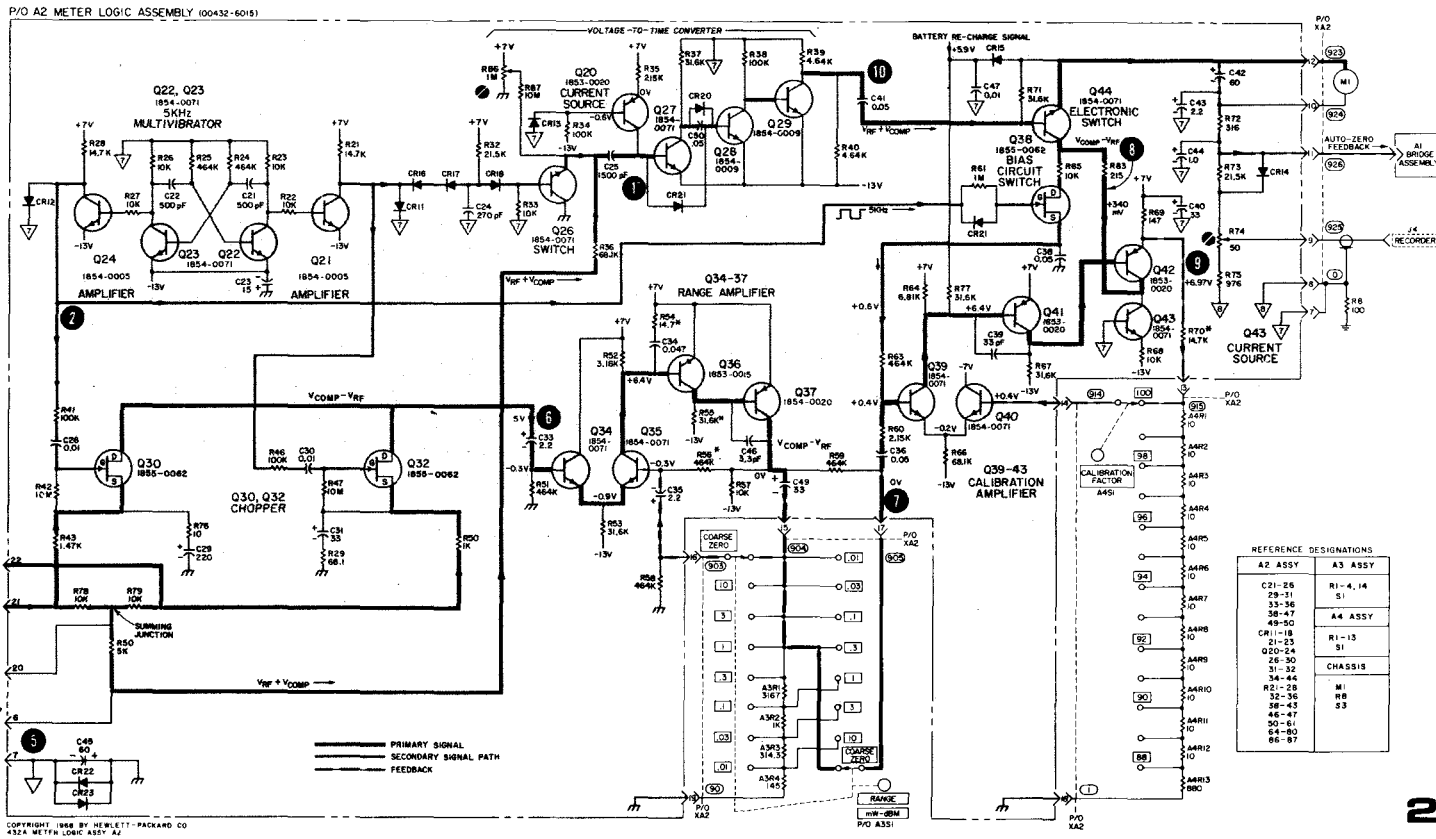

Figure 4-4. Model 432A Meter Logic Talking Schematic (Sheet 1 of 2)

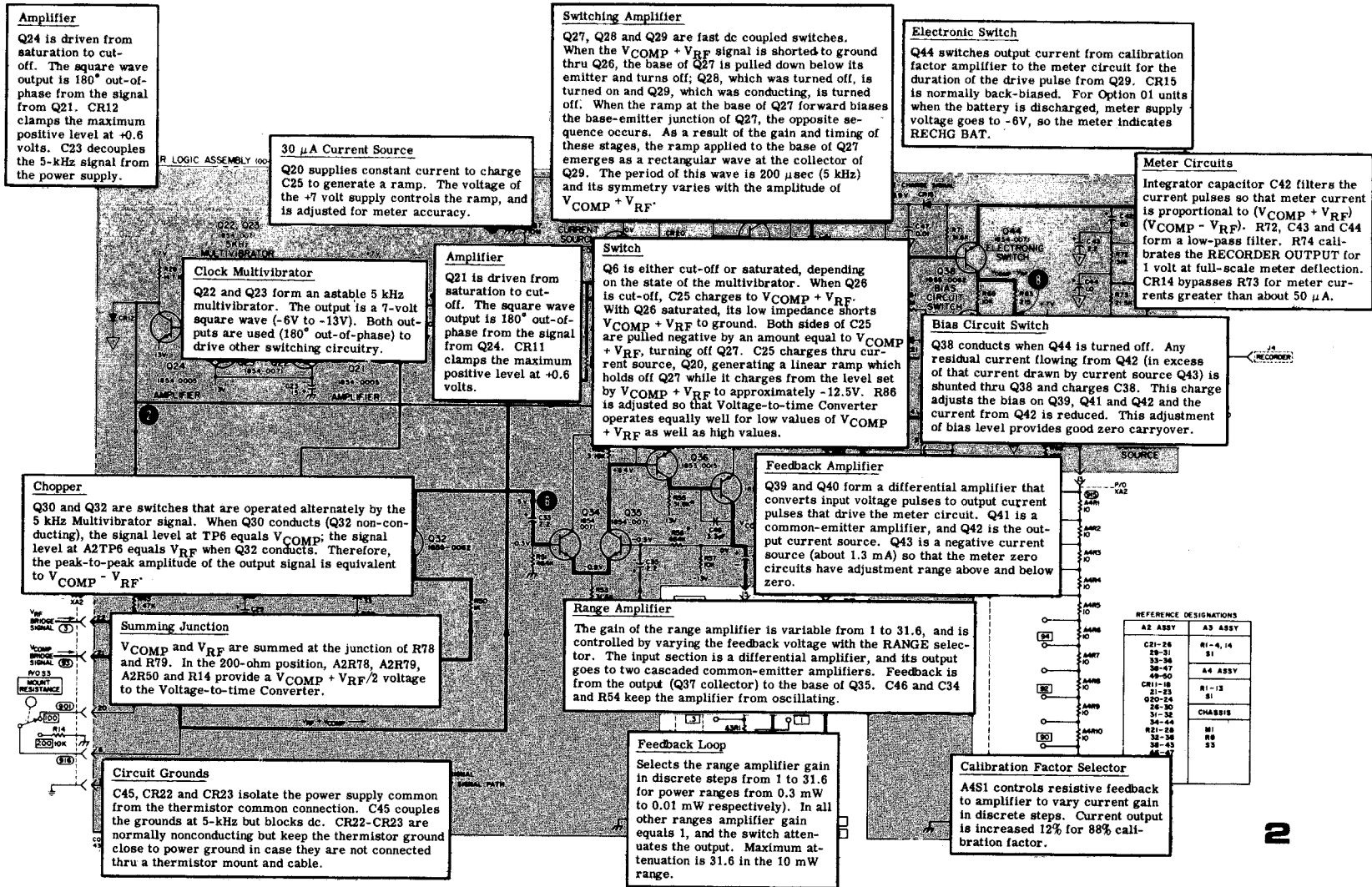

Figure 4-4. Model 432A Meter Logic Talking Schematic (Sheet 2 of 2)

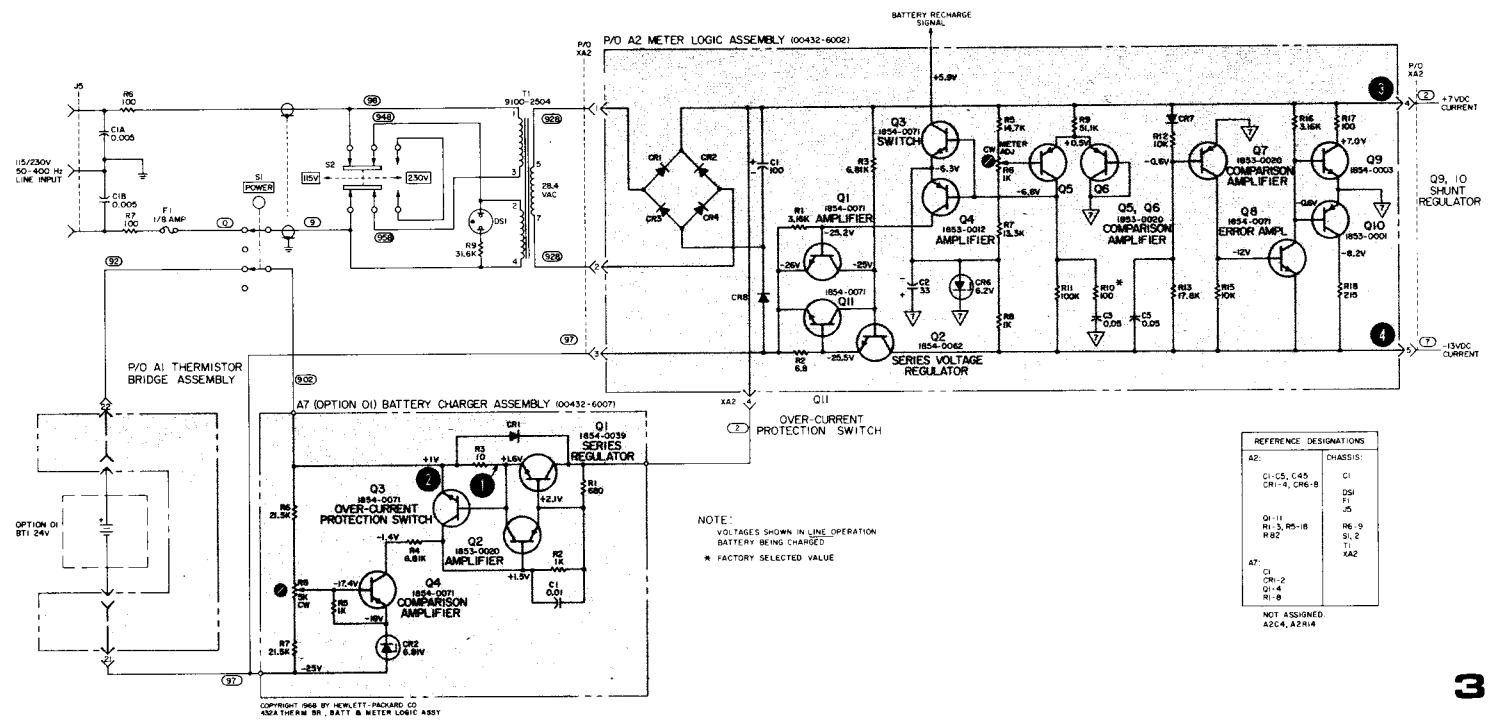

Figure 4-5. Model 432A Power Supply Talking Schematic (Sheet 1 of 2)

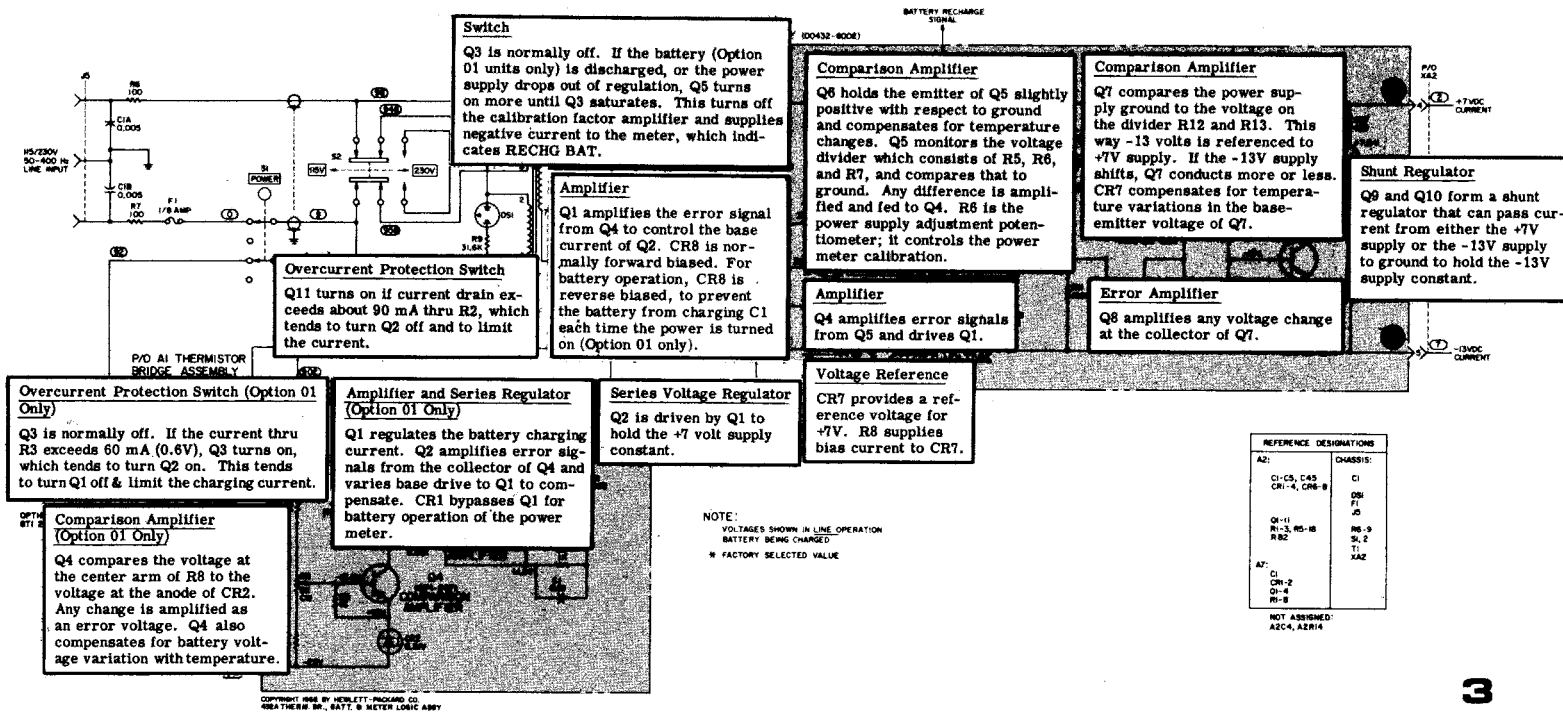

Figure 4-5. Model 432A Power Supply Talking Schematic (Sheet 2 of 2)

Table 5-1. Recommended Test Equipment

Instrument Type	Critical Specifications	Recommended Model
Power Meter Calibrator	Range: 0.1 to 10 mW Accuracy: .1 to 10 mW ranges: 0.2% .01 and .03 mW ranges: 0.5%	HP 8477A
DC Digital Voltmeter	Range: 0.5 to 50 volts dc Accuracy: $\pm 0.05\%$ Input Impedance: 10 megohms, floating Resolution: 4 digits	HP 3440A with 3443A Plug-in Unit
Storage Oscilloscope	Variable Persistence Display Bandwidth: dc to 5 MHz Input Impedance: 1 megohm Sensitivity: 5 mV/division	HP 141A with 1405A and 1420A Plug-in Units
Vertical Plug-in	Bandwidth: 400 kHz Input Impedance: 1 megohm Sensitivity: 1 mV/division	HP 1401A
Cable Assembly (2 required)	RG 58C/U coaxial cable with 2 each BNC male connectors	HP 10503A
Test Lead	Insulated cable terminated with dual banana plug and test clips	HP 11001A
Cable Assembly	Shielded cable with one each BNC and dual banana plug connectors	HP 11000A
Thermistor Mount	Operating Resistance: 100 ohm or 200 ohms	HP 478, 8478
Filter Network		See Figure 5-2
Oscilloscope Probes (2)	Division Ratio: 10:1 $\pm 2\%$ Bandwidth: dc to 30 MHz Rise Time: 5 nsec	HP 10001A
Differential Voltmeter	Accuracy: $\pm 0.005\%$ of reading $+0.0004\%$ of range $\pm 1 \mu\text{V}$	HP 740B
Resistor (2)	10K 1%, 1/8 watt	0757-0442

SECTION V MAINTENANCE

5-1. INTRODUCTION.

5-2. This section provides information for performance testing, adjusting, troubleshooting and repairing the 432A Power Meter. Performance tests allow the instrument to be checked for conformance to specifications. If performance is not within specifications, adjust or troubleshoot the instrument.

5-3. CONTENT.

5-4. PERFORMANCE TESTS .

5-5. The procedures test power meter performance for incoming inspection, periodic evaluation, calibration and troubleshooting, Specifications in Table 1-1 are the performance standards. If the power meter fails to meet any of the performance test specifications. refer to the troubleshooting diagrams.

5-6. ADJUSTMENTS

5-7. Procedures describe the adjustments necessary to calibrate the power meter. Adjust the power meter only when it is determined that the meter is out of adjustment, and not malfunctioning due to a circuit failure.

5-8. To avoid errors due to possible ground loop currents, isolate the power meter from ground used for other auxiliary equipment. A power plug adapter that removes the ground connection at the line outlet can be used to isolate the power meter.

5-9. Several circuit components are factory-selected to meet specific circuit requirements. The factory selected parts are indicated on the schematic diagrams.

5-10. TEST EQUIPMENT.

5-11. Instruments and accessories required for adjusting and testing the power meter are listed and briefly described in Table 5-1. Instruments used to maintain the instrument must meet or exceed the specifications given.

5-12. SERVICE INFORMATION.

5-13. Service information in the form of troubleshooting, waveforms, schematics, and component locations are given in Section VII. Also, an overall system block diagram is included which contains keyed numbers corresponding to the test points.

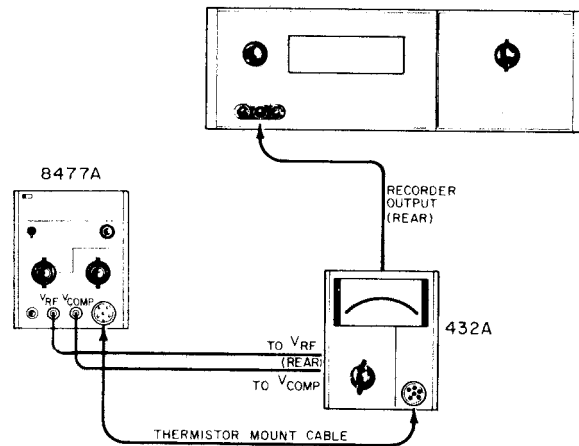

Figure 5-1. Check and Adjustment Test Set-up

5-14. 432A PERFORMANCE TESTS WITH 8477A CALIBRATOR

5-15. INITIAL SET-UP.

a. Connect the 8477A outputs to the 432A inputs as shown in Figure 5-1. Use appropriate test equipment as listed in Table 5-1.

b. If necessary, mechanically zero the meter movement as follows:

- (1) With instrument turned off, rotate meter adjustment screw clockwise until pointer approaches zero mark from the left.
- (2) Continue rotating clockwise until pointer coincides with zero mark. If pointer overshoots, continue rotating adjustment screw clockwise until pointer once again approaches zero mark from the left.
- (3) Rotate adjustment screw about three degrees counterclockwise to disengage screw adjustment from meter suspension.

5-16. METER ACCURACY TEST.

a. Set the 8477A Calibrator controls as follows:

POWER	0.01mW
FUNCTION	200Ω
ZERO/TEST	ZERO

b. Set the 432A controls as follows:

MOUNT RESISTANCE.	200Ω
RANGE	0.01mW
POWERON
CALIBRATION FACTOR	100%

**Section V
Maintenance**

c. Adjust 8477A ZERO knob for 0 volts ± 2 mV indication on the DVM.

d. Set the 8477A controls as follows:

POWER 0.01mW
ZERO/TEST TEST

e. The digital voltmeter should indicate 1000 ± 10 millivolts.

f. The 432A meter should indicate full scale $\pm 1/2$ division.

g. Repeat steps d through f for each of the other ranges. Set the power meter range selector to the position indicated in Column 1 of Table 5-2, and set the 8477A meter reading selector to the corresponding position indicated in Column 2 of Table 5-2. In each case, the meter indications should correspond to those shown in Table 5-2, Columns 3 and 4.

Table 5-2. Meter Accuracy Test

432A Range (mW)	8477A Range (mW)	Digital Voltmeter Indication (millivolts ± 10 mV)	432A Meter Indication (Full scale $\pm 1/2$ Div.)
.01	.01	1000	1
.03	.03	948.8	3
.1	.1	1000	1
.3	.3	948.8	3
1	1	1000	1
3	3	948.8	3
10	10	1000	1

5-17. CALIBRATION FACTOR TEST.

a. Set 432A controls as follows:

RANGE 0.1 mW
CAL FACTOR 88%
MOUNT RESISTANCE 2000

b. Set 8477A controls as follows:

FUNCTION 200 Ω
ZERO/TEST Switch TEST
POWER 0.1mW

c. Set 8477A ZERO control so that the digital voltmeter reads 1000 ± 2 mV.

d. Set the calibration factor selector to 89%.

e. The digital voltmeter should indicate 989 ± 10 millivolts.

f. Repeat steps d and e for each position of the CALIBRATION FACTOR selector. In each case, the digital voltmeter should indicate the voltage shown in the second column of Table 5-3 for the CALIBRATION FACTOR shown in the first column.

Table 5-3. Calibration Factor Test

Calibration Factor Selector Setting (%)	Digital Voltmeter Indication (mV)
88	1000 ± 2
89	989 ± 10
90	978 ± 10
91	967 ± 10
92	957 ± 10
93	946 ± 10
94	935 ± 10
95	926 ± 10
96	916 ± 10
97	907 ± 10
98	897 ± 10
99	889 ± 10
100	880 ± 10

5-18. METER LINEARITY CHECK.

a. Set the 8477A POWER (MW) selector to 1 mW, and FUNCTION to 200 Ω , ZERO/TEST switch to TEST.

b. Set the 432A RANGE selector to 3 mW, MOUNT RESISTANCE to 200 Ω .

c. The 432A meter should indicate 1 mW $\pm 1/2$ division.

d. Set the 8477A POWER (MW) selector to 2 mW.

e. The 432A meter should indicate 2 mW $\pm 1/2$ division.

f. Set the 8477A POWER (MW) selector to 3 mW.

g. The 432A meter should indicate 3 mW $\pm 1/2$ division.

5-19. ZERO CARRYOVER TEST.

a. Disconnect the 432A from the 8477A.

b. Turn the 432A power OFF, and connect the thermistor mount cable to a thermistor mount.

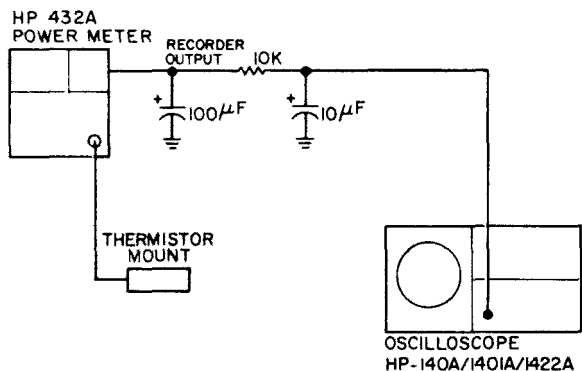

Figure 5-2. Zero Carryover Test Setup

- c. Set the 432A Power Meter MOUNT RESISTANCE selector to the resistance shown on the thermistor mount,
- d. Turn ON the 432A power.
- e. Connect 141A through filtering network to rear of 432A as shown in Figure 5-2. Set 141A controls as follows:

INPUT DC
 Sensitivity 1 mV/cm
 SWEEP ICE 2 sec/cm
 TRIGGER LEVEL max clockwise (free run)

- f. Zero the 432A as follows:
 - 1) Set the RANGE selector maximum cw to COARSE ZERO.
 - 2) Set the COARSE ZERO screwdriver adjust so that the meter indicates zero.
 - 3) Set 432 ARANGE switch to .01 mW. Depress the FINE ZERO switch. The meter indication should to to zero without overshoot.
- g. Rotate the RANGE switch clockwise, one step at a time, while the oscilloscope is sweeping. On each 432 A range, the scope trace should be within .01mW divisions (± 5 mV) from where it was on the .01 mW range,

5-20. FINE ZERO RANGE CHECK.

- a. Set the 432A RANGE selector to 0.3 mW. Leave the thermistor mount connected to the cable, and the MOUNT RESISTANCE selector set to correspond to the resistance of the mount used.
- b. Depress the FINE ZERO switch.
- c. Slowly turn the COARSE ZERO screwdriver adjustment counterclockwise until the meter will no longer zero. The FINE zero circuit is at one end of its range.
- d. Release FINE ZERO.
- e. Set the COARSE ZERO screwdriver adjustment so that the meter indicates full scale on the 0-3 scale (0.3 mW range).

Note. Calibration will be performed in the AN/TSM-55V5 Maintenance Calibration Equipment Shelter.

f. Depress FINE ZERO switch (the fine zero circuit is at the other end of its range). Meter should indicate below 2 on the 0-3 scale. Record the indication.

g. Release FINE ZERO.

h. Rotate RANGE switch to COARSE ZERO position. The fine zero circuit is now in the center of its range. The meter reading should be (1.5 + reading of +1/2 of reading in step f, ± 0.1 on the 0-3 scale.

5-21. 432A CALIBRATION WITHOUT 8477A CALIBRATOR

5-22. The 432A Power Meter can be calibrated without an 8477A Calibrator using a method similar to the precision power method outlined in Paragraph 3-27.

5-23. A major difference between the two measurements is that external power need not be applied when calibrating the instrument. Normally, in a stable environment, the VCOMP output voltage remains constant, not being affected by external RF power; only the VRF output varies during power measurement. Since the power that the meter indicates is proportional to VCOMP and VRF, we can cause the meter to indicate a power also by holding VRF constant and varying VCOMP. This is easily done on the 432A by turning the COARSE ZERO control. Two calibration procedures are given below.

5-24. CALIBRATION PROCEDURE 1.

- a. Connect thermistor mount to power meter; let instrument warm up for at least 10 minutes.
- b. Select range which instrument is to be calibrated on. Note: ranges below 0.3 mW require a precise differential voltmeter capable of resolving 1 μ V. The HP 740B DC Standard/A Voltmeter, which has an accuracy of $\pm(0.005\%$ of reading $\pm 0.0004\%$ of range $\pm 1\mu$ V) is recommended. A digital voltmeter is adequate for the 1.0 mW and higher ranges.
- c. Connect Differential Voltmeter (or DVM differentially) between the VCOMP and VRF output jacks on the rear panel. See Figure 3-3 for location of V_{RF} and VCOMP outputs.
- d. While pressing the FINE ZERO switch, measure and record V₀. (V₀ is the difference of the bridge voltages with no power applied.)
- e. Turn COARSE ZERO control (on front panel) clockwise to a convenient power, e.g., 9 on the zero to 10 scale or 2 on the 0 to 3 scale.
- f. Differentially measure and record V₁. V₁ is the difference voltage between VCOMP and VRF with power applied.
- g. Measure and record VCOMP. Note that the VCOMP jack is isolated from chassis ground; measure from the center conductor of the BNC to the outer conductor.

INSTRUMENT SERIAL NO. _____

DATE _____

TABLE 5-4. PERFORMANCE TEST CARD

Data in this test card corresponds to Performance Tests in Paragraphs 5-16 through 5-20.

TABLE 5-4. PERFORMANCE TEST CARD

Para. Ref.	Test	Measurement Unit	Min.	Actual	Max.	
5-16	<u>METER ACCURACY</u>					
e	0.01 mW applied; measure RECORDER OUT voltage	mVdc	990	_____	1010	
f	Meter indicates full-scale (0-1 scale)	divisions	-1/2	_____	+ 1/2	
	<u>Repeat on remaining 432A power ranges:</u>					
e	Power applied: 0.03 mW	mVdc	938.8	_____	958.8	
f	Meter indication (0-3 scale)	divisions	-1/2	_____	+ 1/2	
e	Power applied: 0.1 mW	m.Vdc	990	_____	1010	
f	Meter indication (0-1 scale)	divisions	-1/2	_____	+1/2	
e	Power applied: 0.3 mW	mVdc	938.8	_____	958.8	
f	Meter indication (0-3 scale)	divisions	-1/2	_____	+1/2	
e	Power applied: 1 mW	mVdc	990	_____	1010	
f	Meter indication (0-1 scale)	divisions	-1/2	_____	+ 1/2	
e	Power applied: 3 mW	mVdc	938.8	_____	958.8	
f	Meter indication (0-3 scale)	divisions	-1/2	_____	+1/2	
e	Power applied: 10 mW	mVdc	990	_____	1010	
f	Meter indication (0-1 scale)	divisions	-1/2	_____	+ 1/2	
5-17	<u>CALIBRATION FACTOR</u>					
i	<u>Calibration Factor (%)</u>	<u>DVM Reading (mVdc)</u>				
	88	1000	mVdc	990	_____	1010
	89	989	mVdc	979	_____	999
	90	978	mVdc	968	_____	988
	91	967	mVdc	957	_____	977
	92	957	mVdc	947	_____	967
	93	946	mVdc	936	_____	956
	94	935	mVdc	925	_____	945
	95	926	mVdc	916	_____	936
	96	916	mVdc	906	_____	926
	97	907	mVdc	897	_____	917
	98	897	mVdc	887	_____	907
	99	889	mVdc	879	_____	899
	100	880	mVdc	870	_____	890

TABLE 5-4. PERFORMANCE TEST CARD

Para. Ref.	Test	Measurement Unit	Min.	Actual	Max.
5-18	<u>METER LINEARITY</u>				
c	1 mW applied, 3 mW scale: meter indicates 1 mW	divisions	-1/2	_____	+1/2
e	2 mW applied, 3 mW scale: meter indicates 2 mW	divisions	-1/2	_____	+1/2
g	3 mW applied, 3 mW scale: meter indicates 3 mW	divisions	-1/2	_____	+1/2
5-19	<u>ZERO CARRY-OVER</u>				
d	Zero carry-over:				
	<u>Range (mW)</u> <u>Scope Indication</u>				
	.01 0 ±5 mVdc	mVdc	-5	_____	+5
	.03 0 ±5 mVdc	mVdc	-5	_____	+5
	.1 0 ±5 mVdc	mVdc	-5	_____	+5
	.3 0 ±5 mVdc	mVdc	-5	_____	+5
	1 0 ±5 mVdc	mVdc	-5	_____	+5
	3 0 ±5 mVdc	mVdc	-5	_____	+5
	10 0 ±5 mVdc	mVdc	-5	_____	+5
5-20	<u>FINE ZERO RANGE</u>				
f	Meter indication on 1-3 scale:	divisions	1.75	_____	2.0
g	Meter indication on 1-3 scale: 1.5+ 1/2 reading of step f.	divisions		_____	1.5

h. Calculate the power using the following formula*:

$$P = \frac{1}{4R} \left[2V_{\text{COMP}} (V_1 - V_0) - V_1^2 \right] \quad (1)$$

where R is the resistance of the thermistor mount and should be identical to the setting of the MOUNT RESISTANCE switch.

i. If calculated power is different from the value that was set with the COARSE ZERO control, adjust A2R6 so that the meter reads calculated power. If the range of A2R6 is insufficient to set new power, it will be necessary to change the value of A2R70.

j. Set COARSE ZERO so that meter reads one on the 0 to 1 scale. Set A2R72 for 1.000 V ± 10 mV at the RECORDER output jack on the rear panel.

5-25. There is a simpler form of the equation that was used to calculate power in step h above. This form ignores V_0 , the small voltage difference between the two bridges with no power applied. However, V_0 becomes negligible on the higher ranges, that is, 1 mV and above, and can be ignored with little decrease in accuracy. The simpler form is as follows:

$$P = \frac{1}{4R} (V_C - V_{\text{RF}}) (V_C + V_{\text{RF}}) \quad (2)$$

5-26. CALIBRATION PROCEDURE 2.

a. Connect thermistor mount to power meter; let instrument warm up for at least 10 minutes.

b. Select 1, 3, or 10 mW range.

c. Turn the COARSE ZERO control clockwise to indicate some convenient on-scale reading.

d. Measure V_{COMP} and record. Note that V_{COMP} jack is isolated from chassis ground; measure from the center conductor of the BNC to the outer conductor.

e. Measure V_{RF} and record. Follow measurement procedure in step d.

f. Measure and record $V_{\text{COMP}} - V_{\text{RF}}$. This term must be measured differentially, that is, one side of the DVM connected to V_{COMP} and the other side connected to V_{RF} . In this way the full resolution of the DVM can be used.

g. Substituting the measured values into the above formula, calculate the power,

h. If calculated power is different from the power set with the COARSE ZERO control, adjust A2R6 so that meter indicates that power. If the range of A2R6 is not great enough to set new power level, the value of A2R70 will have to be changed.

i. Adjust COARSE ZERO so that meter reads 1 on the 0 to 1 scale. Set A2R72 for 1.000 V ± 10 mV at the RECORDER output jack on the rear panel.

*This formula is accurate for on-scale readings; however, with no power applied (i. e., $V_1 = V_0$) it does not solve to $P = 0$ because of a deleted term $+ V_0$. This term can be neglected for any on-scale reading.

5-27. COVER REMOVAL AND REPLACEMENT.

5-28. The side covers can be removed and replaced independently of the top and bottom covers. Each side cover is held in place by four screws retained by nuts which are fastened to the side frames.

5-29. TOP COVER REMOVAL.

a. At the rear of the instrument, remove the screw that retains the cover.

b. Grasp the cover from the rear, and slide it back 1/2 inch. Then tilt forward edge of the cover upward and lift the cover from the instrument.

5-30. TOP COVER REPLACEMENT.

a. Rest the cover flat on the cast guides projecting inward near the top of each side frame.

b. Slide the cover forward, allowing its forward edge to enter the groove in the front panel.

c. Replace the cover retaining screw.

5-31. BOTTOM COVER REMOVAL.

a. Remove the retaining screw at the rear of the cover.

b. Swing the tilt stand out to free the cover

c. Slide the cover rearward far enough to free the forward edge.

d. Tilt the forward edge of the cover upward and lift the cover from the instrument.

5-32. BOTTOM COVER REPLACEMENT.

a. Set the tilt stand out of the way of the cover

b. Rest the bottom cover flat on the cast guides projecting inward near the bottom of each side frame.

c. Slide the cover forward on the guides so that the formed portion at the rear of the cover slides over the two short projections at the rear corner of each side frame.

d. Replace the retaining screw.

5-33. ADJUSTMENT PROCEDURES.

5-34. INITIAL SETUP.

a. Remove the power meter side panels.

b. Connect the equipment as shown in Figure 5-1. Refer to Table 5-1 for equipment specifications.

5-35. MECHANICAL METER ADJUSTMENT.

a. When the meter is properly zero-set, the pointer rests over the zero mark on the meter scale when the instrument is:

- (1) at normal operating temperature
- (2) in its normal operating position
- (3) turned off

b. Set the pointer as follows to obtain best accuracy and mechanical stability:

- (1) Turn instrument off.
- (2) Rotate the meter mechanical adjustment screw clockwise until the meter pointer is to the left of zero and moving up the scale toward zero. Stop when the pointer is exactly over the zero mark. If the pointer overshoots, repeat step 2.
- (3) When the pointer is exactly on zero, rotate the adjustment screw approximately 3 degrees counterclockwise. This frees the adjustment screw from the meter suspension. If the pointer moves during this step, repeat steps 2 and 3.

5-36. BRIDGE AMPLIFIER TESTS

- a. Connect equipment as shown in Figure 5-3.
- b. Compensation Bridge.
 1. Connect 3440A/3443A between A1TP5 and A1TP6 (using 10K isolation resistors).

2. Make the following settings:

432A
 RANGE 10mW
 MOUNT RESISTANCE 200Ω
 FUNCTION 8477A
 SET

3. Adjust A1R12 (OFFSET ADJUST) for 0.0 ±0.1 mV dc reading on the digital voltmeter.
4. Change 8477A FUNCTION to CHECK. The digital VM reading should not exceed ±0.4 mVdc.

c. RF BRIDGE

1. Connect DVM between A1TP3 and A1TP4 using 10 kΩ isolation resistors in series with the leads.
3. Set 8477A FUNCTION to SET. Adjust A1R15 (OFFSET ADJUST) for DVM reading of 0.0 ± 0.1 mVdc.

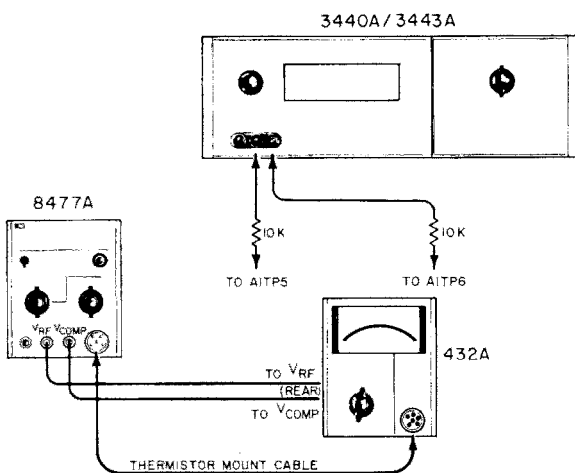

Figure 5-3. Bridge Amplifier Test

4. Change 8477A FUNCTION to CHECK. The reading should not exceed ±0.4 mVdc.

Note: Failure of the instrument to meet the specification of steps (4) of b and c above indicates insufficient bridge gain. Refer to Table 7-3 or 7-4 in the troubleshooting section.

5-37. METER AND RECORDER OUTPUT CALIBRATION

- a. Connect the DVM to the 432A RECORDER output.
- b. Set 8477A controls as follows:
 FUNCTION 200Ω
 ZERO/TEST ZERO
 POWER 1mw

- c. Set 432A controls as follows:
 MOUNT RES 200Ω
 RANGE 1mW
 CAL FACTOR 100%

d. Adjust ZERO control on 8477A for DVM indication of 0.000 ±0.001V.

e. ZERO/TEST on 8477A to TEST

f. Adjust A2R6 in 432A for 432A meter reading of 1.0 mW ±0.1 mW.

g. Adjust A2R74 in 432A for DVM reading of 1.0V ±.001V

h. Change the following settings:

432A RANGE to 10 mW
 8477A POWER (mW) to 10 mW and ZERO/TEST to ZERO.

Note: When switching 432A to 10 mW or switching from 10 mW to any other range, the meter will react slowly for a short period. This is due to time constants in the instrument and is normal.

i. Zero instrument as in step d and c.

j. Adjust A2R86 for DVM reading of 1.00 ±0.00 IV.

k. Return 432A RANGE and 8477A POWER switches to 1 mW and zero as before.

l. Adjust A2R6 for DVM reading of 1.000 ±0.00 1V.

m. Perform the adjustments of steps h through l again until 432A reads 1 ±0.010V (at recorder output) on both 1 mW and 10 mW ranges.

n. Turn to the beginning of this section; verify that the instrument meets its specifications by completing the PERFORMANCE TESTS.

5-38. BATTERY CHARGER ADJUSTMENT (OPTION 01 ONLY)

- a. Remove the power meter top panel.
- b. Connect 432A to ac line power and turn ON.

- c. Set A7R8 fully clockwise for maximum battery charge rate.
- d. With the digital voltmeter, measure the voltage between A7TP1 and A7TP2.
- e. Adjust A7R8 for digital voltmeter reading of 0.2 to 0.4 volts (20 to 40 mA through R3).
- f. Disconnect the test equipment and power and replace the power meter top and side panels.

5-39. BATTERY REMOVAL

- a. Remove the top cover.
- b. Remove the two Phillips screws on the top rear of the battery cover.
- c. Lift off the battery cover.
- d. Loosen the nuts on the battery binding posts.
- e. Lift out the battery.

5-40. **ISOLATING TROUBLE IN TRANSISTOR CIRCUITS.**

5-41. General. The following information should help determine if a transistor works. There are tests for both in-circuit and out-of-circuit transistors, which help to determine if a particular trouble is due to a faulty transistor or some other component. See Figure 5-2.

5-42. hi-circuit Testing. Intransistor Circuit testing the most important consideration is the transistor base-emitter junction. Like the control grid of a vacuum tube, this is the control point in the transistor.

5-43. To check a transistor, first see if the emitter-base diode is forward-biased by measuring the voltage difference between emitter and base. When using an electronic voltmeter, do not measure directly between emitter and base; there may be sufficient loop current between the voltmeter lead to damage the transistor. Instead, measure each voltage separately with respect to a voltage common point (e.g., chassis).

5-44. If the transistor base-emitter junction is forward-biased, the transistor conducts. If the diode is heavily forward-biased, the transistor saturates. However, if the base-emitter diode is reverse-biased, the transistor is cut off (open). The voltage drop across a forward-biased emitter-base junction varies with transistor collector current. A germanium transistor has a typical base-emitter voltage of 0.2-0.3 volt with 1-10 mA collector current, and 0.4-0.5 volt with 10-100 mA collector current. In contrast, base-emitter voltage for silicon transistors is about twice that for germanium types; about 0.5-0.6 volt for low collector current, and about 0.8-0.9 for high collector current.

5-45. If the emitter base-junction is forward-biased, check for amplifier action by short-circuiting base to emitter while observing collector voltage. The transistor should stop conduction (cut off), which should shift the collector voltage close to the supply voltage. Any difference is due to current leadage through the transistor. In general, the smaller the current, the better the transistor. If collector voltage does not change, the transistor has either an emitter-collector short circuit or emitter-base open circuit.

5-46. OUT-OF-CIRCUIT TESTING,

5-47. The two common causes of transistor failure are internal short - and open-circuits. Remove the transistor from the circuit and use an ohmmeter to measure internal resistance. See Table 5-5 for measurement data.

Table 5-5. Out-of-Circuit Transistor Resistance Measurements

Transistor Type		Connect Ohmmeter		Measure Resistance (ohms)
		Positive Lead to	Negative Lead to	
PNP Germanium	Small Signal	emitter	base *	200-500
		emitter	collector	10K - 100K
	Power	emitter	base*	30 - 50
		emitter	collector	several hundred
NPN Silicon	Small Signal	base	emitter	1K - 3K
		collector	emitter	very high (might read open)
	Power	base	emitter	200 -1000
		collector	emitter	high, often greater than 1M

* To test for transistor action, add collector -base short. Measured resistance should decrease.

DEVICE	SYMBOL	CUT OFF	CONDUCTING
NPN TRANSISTOR			
PNP TRANSISTOR			

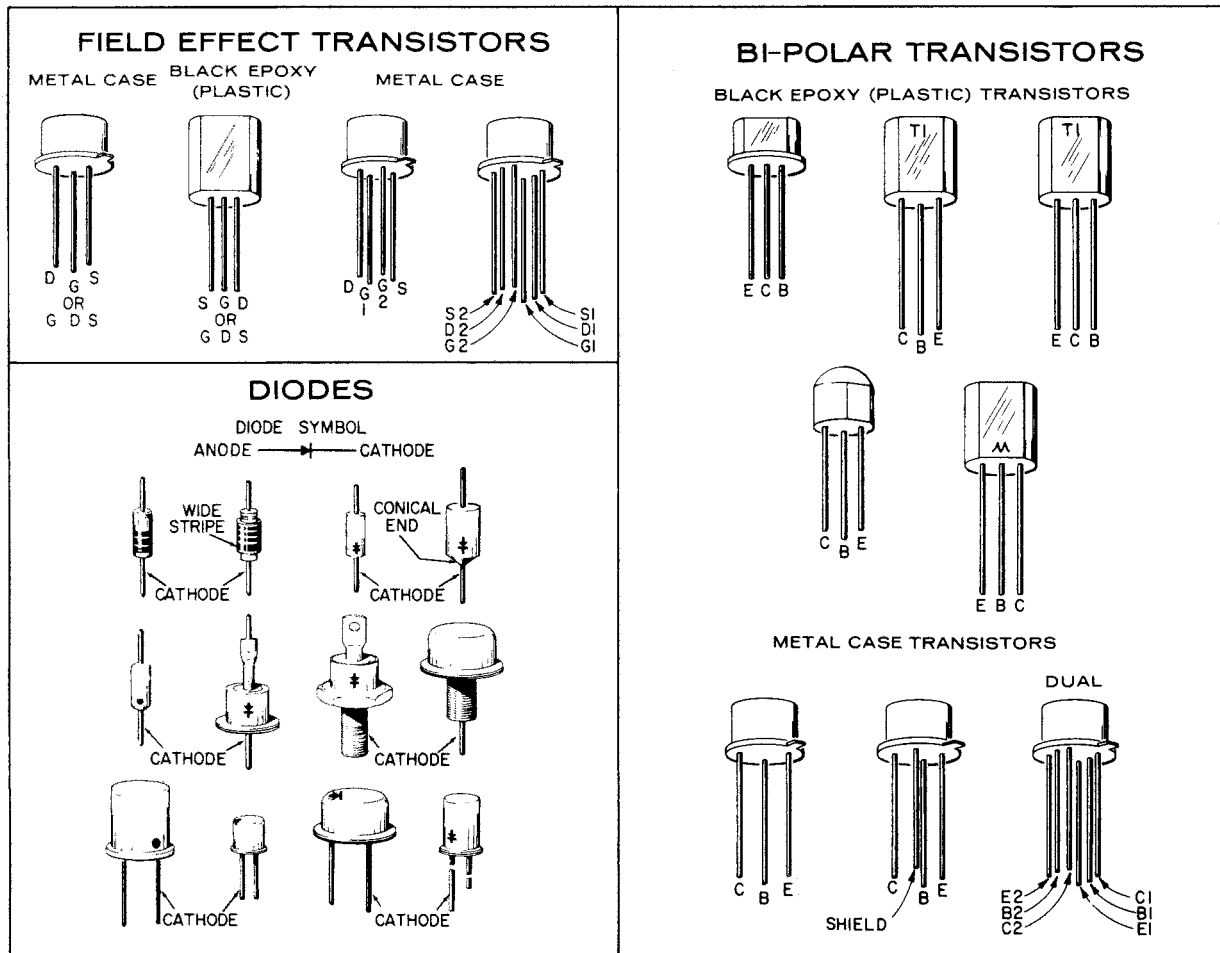

Figure 5-4. Transistor Biasing and Operating Characteristics

Table 5-6. Etched Circuit Soldering Equipment

Item	Use	Specification	Item Recommended
Soldering Tool	Soldering, unsoldering	Wattage rating: 37.5 Tip temp: 750-800°F Tip size: 1/8" OD	Ungar #776 handle with Ungar #1237
Soldering Tip, General Purpose	Soldering, unsoldering	Shape: chisel Size: 1/8"	Ungar #PL113
De-soldering Aid	Unsoldering multiconnection components	Suction device to remove molten solder from connection	Soldapult by the Edsyn Company, Arleta, Calif.
Resin (flux) Solvent	Remove excess flux from soldered area before application of protective coating.	Must not dissolve etched circuit base board material or conductor bonding agent.	Freon, Acetone, Lacquer Thinner, Isopropyl Alcohol (100% dry)
Solder	Component replacement, circuit board repair, wiring	Resin (flux) core, high tin content (60/40 tin/lead), 18 gauge (SWG) preferred	
Protective Coating	Contamination, corrosion protection after soldering	Good electrical insulation, corrosion-prevention properties	Krylon #1302*, Humiseal Protective Coating, Type 1B12 by Columbia Technical Corp., Woodside 77, New York
*Krylon, Inc., Norristown, Pennsylvania			

Table 5-7. Safe Ohmmeter Range for Transistor Resistance Measurements

Ohmmeter	Safe Range(s)	Open Circuit Voltage	Short Circuit Current	Lead	
				Color	Polarity
HP 412A HP 427A	R x 1 k R x 10 k R x 100 k R x 1M R x 10M	1.0 V 1.0 V 1.0 V 1.0 V 1.0 V	1 mA 100 μA 10 μA 1 μA 0.1 μA	Red Black	+ -
HP 410C	R x 1 k R x 10 k R x 100 k R x 1M R x 10M	1.3 V 1.3 V 1.3 V 1.3 V 1.3 V	0.57 mA 57 μA 5.7 μA 0.5 μA 0.05 μA	Red Black	+ -
HP 410B	R x 100 R x 1 k R x 10 k R x 100 k R x 1M	1.1 V 1.1 V 1.1 V 1.1 V 1.1 V	1.1 mA 110 μA 11 μA 1.1 μA 0.11 μA	Black Red	+ -
Simpson 260	R x 100	1.5 V	1 mA	Red Black	+ -
Simpson 269	R x 1 k	1.5 V	0.82 mA	Black Red	+ -
Triplet 630	R x 100 R x 1 k	1.5 V 1.5 V	3.25 mA 325 μA	Varies with Serial Number	
Triplet 310	R x 10 R x 100	1.5 V 1.5 V	750 μA 75 μA		

5-48. COMPONENT REPLACEMENT IN
ETCHED CIRCUITS.

5-49. General. Etched circuit boards are sensitive to heat and to scratches with sharp objects. This is because the conductors are plated on to the circuit boards and the plating extends through the component mounting holes. Whenever possible, avoid unnecessary component substitution; it can damage the circuit board and adjacent components. See Table 5-6 for recommended tools and materials.

5-50. AXIAL-LEAD COMPONENTS .

5-51. Resistors, tubular capacitors and other axial-lead components can be replaced without unsoldering. Cut the component leads near the body of the defective component, remove the component and straighten the leads left in the board. Wrap leads of the replacement component one turn around the original leads, solder the connection, and clip off the excess lead.

5-52. OTHER COMPONENTS.

5-53. Replace other components as follows:

a. Remove defective component from circuit board. Use a low-power soldering iron because excessive heat may lift a conductor or damage the board.

b. Remove solder from mounting holes with a suction device or a wooden toothpick. DO NOT USE A SHARP METAL OBJECT SUCH AS AN AWL OR TWIST DRILL. SHARP OBJECTS MAY DAMAGE THE PLATED-THROUGH CONDUCTOR.

c. Shape the leads of the replacement component to match the mounting-hole spacing.

d. Insert the component leads in the mounting holes and position it as the original was. DO NOT FORCE LEADS OF REPLACEMENT COMPONENT INTO MOUNTING HOLES. A sharp edge on the lead may damage the plated-through conductor.

e. Solder the component in place and remove excess flux from the soldered areas. Apply a protective coating to prevent contamination and corrosion. See Table 5-6 for recommendations.

CAUTION

Most ohmmeters can supply enough current or voltage to damage a transistor. Before using an ohmmeter to measure transistor forward or reverse resistance, check its open-circuit voltage and short-circuit current output ON THE RANGE TO BE USED. Open-circuit voltage must not exceed 1.5volts and short-circuit current must be less than 3 mA.

SECTION VI

REPLACEABLE PARTS

6-1. INTRODUCTION.

6-2. This section contains information for ordering replacement parts. Table 6-1 lists parts in alpha-numerical order of their reference designators and indicates the description and HP stock number of each part, together with any applicable notes. Miscellaneous parts are listed at the end of Table 6-1, Table 6-2 lists parts in alpha-numerical order of their HP stock number and provides the following information on each part:

- a. Description.
- b. Manufacturer of the part in a five-digit code; see list of manufacturers in Table 6-3.
- c. Manufacturer's part number.
- d. Total quantity used (TQ column).

6-3. ORDERING INFORMATION.

6-4. To obtain replacement parts for Power Meter 432A, refer to Appendix

D, table D-1, Repair Parts List.

6-5. To obtain a part that is not listed, include:

- a. Instrument model number.
- b. Instrument serial number.
- c. Description of the part.
- d. Function and location of the part.

REFERENCE DESIGNATORS

A	= assembly	F	= fuse	MP	= mechanical part	V	= vacuum, tube, neon bulb, photocell, etc.
B	= motor	FL	= filter	P	= plug	VR	= voltage regulator
BT	= battery	IC	= integrated circuit	Q	= transistor	W	= cable
C	= capacitor	J	= jack	R	= resistor	X	= socket
CP	= coupler	K	= relay	RT	= thermistor	Y	= crystal
CR	= diode	L	= inductor	S	= switch	Z	= tuned cavity, network
DL	= delay line	LS	= loud speaker	T	= transformer		
DS	= device signaling (lamp)	M	= meter	TB	= terminal board		
E	= misc electronic part	MK	= microphone	TP	= test point		

ABBREVIATIONS

A	= amperes	H	= henries	N/O	= normally open	RMO	= rack mount only
AFC	= automatic frequency control	HDW	= hardware	NPO	= negative positive zero (zero temperature coefficient)	RMS	= root-mean square
AMPL	= amplifier	HEX	= hexagonal			RWV	= reverse working voltage
BFO	= beat frequency oscillator	HG	= mercury			S-B	= slow-blow
BE CU	= beryllium copper	HR	= hour(s)	NPN	= negative-positive-negative	SCR	= screw
BH	= binder head	HZ	= hertz	NRFR	= not recommended for field replacement	SE	= selenium
BP	= bandpass	IF	= intermediate frequency	NSR	= not separately replaceable	SECT	= section(s)
BRS	= brass	IMPG	= impregnated			SEMICON	= semiconductor
BWO	= backward wave oscillator	INCD	= incandescent			SI	= silicon
CCW	= counter-clockwise	INCL	= include(s)	OBD	= order by description	SIL	= silver
CER	= ceramic	INS	= insulation(ed)	OH	= oval head	SL	= slide
CMO	= cabinet mount only	INT	= internal	OX	= oxide	SPG	= spring
COEF	= coefficient	K	= kilo = 1000			SPL	= special
COM	= common	LH	= left hand	P	= peak	SST	= stainless steel
COMP	= composition	LIN	= linear taper	PC	= printed circuit	SR	= split ring
COMPL	= complete	LK WASH	= lock washer	PF	= picofarads = 10 ⁻¹²	STL	= steel
CONN	= connector	LOG	= logarithmic taper	PH BRZ	= phosphor bronze	TA	= tantalum
CP	= cadmium plate	LPF	= low pass filter	PHL	= Phillips	TD	= time delay
CRT	= cathode-ray tube	M	= milli = 10 ⁻³	PIV	= peak inverse voltage	TGL	= toggle
CW	= clockwise	MEG	= meg = 10 ⁶	PNP	= positive-negative-positive	THD	= thread
DEPC	= deposited carbon	MET FLM	= metal film	P/O	= part of	TI	= titanium
DR	= drive	MET OX	= metallic oxide	POLY	= polystyrene	TOL	= tolerance
ELECT	= electrolytic	MFR	= manufacturer	PORC	= porcelain	TRIM	= trimmer
EN CAP	= encapsulated	MHZ	= mega hertz	POS	= position(s)	TWT	= traveling wave tube
EXT	= external	MINAT	= miniature	POT	= potentiometer	U	= micro = 10 ⁻⁶
F	= farads	MOM	= momentary	PP	= peak-to-peak	VAR	= variable
FH	= flat head	MTG	= mounting	PT	= point	VDCW	= dc working volts
FIL H	= fillister head	MY	= "mylar"	PWV	= peak working voltage	W/	= with
FXD	= fixed	N	= nano (10 ⁻⁹)	RECT	= rectifier	W	= watts
G	= giga (10 ⁹)	N/C	= normally closed	RF	= radio frequency	WIV	= working inverse voltage
GE	= germanium	NE	= neon	RH	= round head or right hand	WW	= wirewound
GL	= glass	NI PL	= nickel plate			W/O	= without
GRD	= ground(ed)						

Table 6-1. Reference Designation Index

Reference Designation	Part No.	Description #	Note
A1	00432-6001	BOARD AS SY:BRIDGE	
	00432-2001	BOARD: BLANK PC	
A1C1	0180-0374	C:FXD ELECT 10 UF 10% 20VDCW	
A1C2	0160-2930	C:FXD CER 0.01 UF +80-20% 100VDCW	
A1C3	0160-2930	C:FXD CER 0.01 UF +80-20% 100VDCW	
A1C4	0160-0380	C:FXD MY 0.22 UF 10% 200VDCW	
A1C5	0160-2930	C:FXD CER 0.01 UF +80-20% 100VDCW	
A1C6	0160-2930	C:FXD CER 0.01 UF +80-20% 100VDCW	
A1C7	0160-2930	C:FXD CER 0.01 UF +80-20% 100VDCW	
A1C8	0160-0380	C:FXD MY 0.22 UF 10% 200VDCW	
A1C9	0160-2930	C:FXD CER 0.01 UF +80-20% 100VDCW	
A1C10	0160-2930	C:FXD CER 0.01 UF +80-20% 100VDCW	
A1C11	0160-2930	C:FXD CER 0.01 UF +80-20% 100VDCW	
A1C12	0180-0374	C:FXD ELECT 10 UF 10% 20VDCW	
A1C13	0160-2264	C:FXD CER 20 PF 5% 500VDCW	
A1C14	0160-2264	C:FXD CER 20 PF 5% 500VDCW	
A1CR1	1901-0040	DIODE:SILICON 30MA 30WV	
A1CR2	1901-0040	DIODE:SILICON 30MA 30WV	
A1Q1	1853-0020	TRANSISTOR:SILICON PNP	
A1Q2	1853-0020	TRANSISTOR: SILICON PNP	
A1Q3	1853-0020	TRANSISTOR:SILICON PNP	
A1Q4	1854-0071	TRANSISTOR:SILICON NPN	
A1Q5	1854-0071	TRANSISTOR:SILICON NPN	
A1Q6	1853-0001	TRANSISTOR:PNP SILICON 30V 900MW	
A1Q7	1854-0221	TRANSISTOR DUAL:SILICON NPN FACTORY SELECTED PART	
A1Q8	1854-0071	TRANSISTOR: SILICON NPN	
A1Q9	1854-0071	TRANSISTOR:SILICON NPN	
A1Q10	1854-0071	TRANSISTOR:SILICON NPN	
A1Q11	1853-0001	TRANSISTOR:PNP SILICON 30V 900MW	
A1Q12	1854-0221	TRANSISTOR DUAL:SILICON NPN FACTORY SELECTED PART	
A1Q13	1854-0071	TRANSISTOR:SILICON NPN	
A1Q14	1853-0020	TRANSISTOR: SILICON PNP	
A1Q15	1853-0020	TRANSISTOR:SILICON PNP	
A1R1	0698-3260	R:FXD MET FLM 464K OHM 1% 1/8W	
A1R2	0686-1055	R:FXD COMP 1 MEGOHM 5% 1/2W	
A1R3	0698-3160	R:FXD MET FLM 31.6K OHM 1% 1/8W	
A1R4		NOT ASSIGNED	
A1R5	0698-3160	R:FXD MET FLM 31.6K OHM 1% 1/8W	
A1R6	0698-3160	R:FXD MET FLM 31.6K OHM 1% 1/8W	

See introduction to this section for ordering information

Table 6-1. Reference Designation Index (Cont'd)

Reference Designation	Part No.	Description #	Note
A1R7	0698-3156	R:FXD MET FLM 14.7K OHM 1% 1/8W	
A1R8	0757-0465	R:FXD MET FLM 100K OHM 1% 1/8W	
A1R9	0698-3136	R:FXD MET FLM 17.8K OHM 1% 1/8W	
A1R10	0698-3441	R:FXD MET FLM 215 OHM 1% 1/8W	
A1R11	0757-0416	R:FXD MET FLM 511 OHM 1% 1/8W	
A1R12	2100-1770	R:VAR WW 100 OHM 10% LIN 1/2W	
A1R13	0757-0461	R:FXD MET FLM 68.1K OHM 1% 1/8W	
A1R14	0811-2284	R:FXD WW 1K OHM 0.1% 1/40W	
A1R15	2100-1770	R:VAR WW 100 OHM 10% LIN 1/2W	
A1R16	0811-2284	R:FXD WW 1K OHM 0.1% 1/40W	
A1R17	0757-0199	R:FXD MET FLM 21.5K OHM 1% 1/8W	
A1R18		NOT ASSIGNED	
A1R19	0698-3441	R:FXD MET FLM 215 OHM 1% 1/8W	
A1R20	0698-3160	R:FXD MET FLM 31.6K OHM 1% 1/8W	
A1R21	0698-3160	R:FXD MET FLM 31.6K OHM 1% 1/8W	
A1R22	0698-3156	R:FXD MET FLM 14.7K OHM 1% 1/8W	
A1R23	0757-0465	R:FXD MET FLM 100K OHM 1% 1/8W	
A1R24	0757-0416	R:FXD MET FLM 511 OHM 1% 1/8W	
A1R25		NOT ASSIGNED	
A1R26	0757-0461	R:FXD MET FLM 68.1K OHM 1% 1/8W	
A1R27	0811-2284	R:FXD WW 1K OHM 0.1% 1/40W	
A1R28	0757-0199	R:FXD MET FLM 21.5K OHM 1% 1/8W	
A1R29	0811-2284	R:FXD WW 1K OHM 0.1% 1/40W	
A1R30	0757-0199	R:FXD MET FLM 21.5K OHM 1% 1/8W	
A1R31	0698-3260	R:FXD MET FLM 464K OHM 1% 1/8W	
A1R32		NOT ASSIGNED	
A1R33	0757-0465	R:FXD MET FLM 100K OHM 1% 1/8W	
A1R34	0757-0465	R:FXD MET FLM 100K OHM 1% 1/8W	
A1R35	0757-0442	R:FXD MET FLM 10.0K OHM 1% 1/8W	
A1R36	0757-0279	R:FXD MET FLM 3.16K OHM 1% 1/8W	
A1R37	0757-0279	R:FXD MET FLM 3.16K OHM 1% 1/8W	
A1R38	0757-0279	R:FXD MET FLM 3.16K OHM 1% 1/8W	
A1R39	0757-0279	R:FXD MET FLM 3.16K OHM 1% 1/8W	
A1R40	0698-3160	R:FXD MET FLM 31.6K OHM 1% 1/8W	
A1R41	0698-3160	R:FXD MET FLM 31.6K OHM 1% 1/8W	
A1R42		NOT ASSIGNED	
A1R43	0757-0442	R:FXD MET FLM 10.0K OHM 1% 1/8W	
A1	0360-0124	TERMINAL:SOLDER LUG	
A1A1	00432-6011	ASSY:AUTO ZERO	

See introduction to this section for ordering information

Table 6-1. Reference Designation Index (Cont'd)

Reference Designation	Part No.	Description #	Note
A2	00432-6015	BOARD ASSY:LOGIC	
	00432-2015	BOARD:BLANK PC	
A2C1	0180-1819	C:FXD ELECT 100 UF +75-10% 50VDCW	
A2C2	0180-0229	C:FXD ELECT 33 UF 10% 10VDCW	
A2C3	0160-2917	C:FXD CER 0.05 UF +80-20% 100VDCW	
A2C4		NUT ASSIGNED	
A2C5	0160-2917	C:FXD CER 0.05 UF +80-20% 100VDCW	
A2C6-		NOT ASSIGNED	
A2C20		NOT ASSIGNED	
A2C21	0140-0234	C:FXD MICA 500 PF 1%	
A2C22	0140-0234	C:FXD MICA 500 PF 1%	
A2C23	0180-1746	C:FXD ELECT 15 UF 10% 20VDCW	
A2C24		NUT ASSIGNED	
A2C25	0160-0978	C:FXD MICA 1500 PF 1% 500VDCW	
A2C26	0160-2930	C:FXD CER 0.01 UF +80-20% 100VDCW	
A2C27		NOT ASSIGNED	
A2C28		NOT ASSIGNED	
A2C29	0180-2178	C:FXD ELECT 220 UF 20% 8VDCW	
A2C30	0160-2930	C:FXD CER 0.01 UF +80-20% 100VDCW	
A2C31	0180-1940	C:FXD ELECT 33 UF 10% 15VDCW	
A2C32		NUT ASSIGNED	
A2C33	0180-0197	C:FXD ELECT 2.2 UF 10% 20VDCW	
A2C34	0160-2672	C:FXD MY 0.047 UF 5% 80VDCW	
A2C35	0180-0197	C:FXD ELECT 2.2 UF 10% 20VDCW	
A2C36	0160-2917	C:FXD CER 0.05 UF +80-20% 100VDCW	
A2C37		NUT ASSIGNED	
A2C38	0160-2917	C:FXD CER 0.05 UF +80-20% 100VDCW	
A2C39	0160-2150	C:FXD MICA 33 PF 5%	
A2C40	0180-0229	C:FXD ELECT 33 UF 10% 10VDCW	
A2C41	0160-2917	C:FXD CER 0.05 UF +80-20% 100VDCW	
A2C42	0180-0106	C:FXD ELECT 60 UF 20% 6VDCW	
A2C43	0180-0197	C:FXD ELECT 2.2 UF 10% 20VDCW	
A2C44	0180-0291	C:FXD ELECT 1.0 UF 10% 35VDCW	
A2C45	0180-0106	C:FXD ELECT 60 UF 20% 6VDCW	
A2C46	0150-0059	C:FXD CER 3.3-0.25 PF 500VDCW	
A2C47	0160-2930	C:FXD CER 0.01 UF +80-20% 100VDCW	
A2C48	0140-0192	C:FXD MICA 68 PF 5%	
A2C49	0180-0229	C:FXD ELECT 33 UF 10% 10VDCW	
A2C50	0160-2917	C:FXD CER 0.05 UF +80-20% 100VDCW	
A2CR1	1901-0026	DIODE:SILICON 0.75A 200 PIV	
A2CR2	1901-0026	DIODE:SILICON 0.75A 200 PIV	
A2CR3	1901-0026	DIODE:SILICON 0.75A 200 PIV	
A2CR4	1901-0026	DIODE:SILICON 0.75A 200 PIV	
A2CR5		NOT ASSIGNED	

See introduction to this section for ordering information

Table 6-1. Reference Designation Index (Cont'd)

Reference Designation	Part No.	Description #	Note
A2CR6	1902-0033	DIODE BREAKDOWN:6.2V	
A2CR7	1901-0040	DIODE:SILICON 30MA 30WV	
A2CR8	1901-0026	DIODE:SILICON 0.75A 200 PIV	
A2CR9		NOT ASSIGNED	
A2CR10		NOT ASSIGNED	
A2CR11	1901-0040	DIODE:SILICON 30MA 30WV	
A2CR12	1901-0040	DIODE:SILICON 30MA 30WV	
A2CR13	1901-0040	DIODE:SILICON 30MA 30WV	
A2CR14	1901-0040	DIODE:SILICON 30MA 30WV	
A2CR15	1901-0040	DIODE:SILICON 30MA 30WV	
A2CR16	1901-0040	DIODE:SILICON 30MA 30WV	
A2CR17	1901-0040	DIODE:SILICON 30MA 30WV	
A2CR18	1901-0040	DIODE:SILICON 30MA 30WV	
A2CR19	1901-0040	DIODE:SILICON 30MA 30WV	
A2CR20	1901-0040	DIODE:SILICON 30MA 30WV	
A2CR21	1901-0040	DIODE:SILICON 30MA 30WV	
A2CR22	1901-0040	DIODE:SILICON 30MA 30WV	
A2CR23	1901-0040	DIODE:SILICON 30MA 30WV	
A2Q1	1854-0071	TRANSISTOR: SILICON NPN	
A2Q2	1854-0062	TRANSISTOR: SILICON NPN 2N1701	
A2Q3	1854-0071	TRANSISTOR: SILICON NPN	
A2Q4	1853-0012	TRANSISTOR:PNP SILICON 2N2904A	
A2Q5	1853-0020	TRANSISTOR: SILICON PNP	
A2Q6	1853-0020	TRANSISTOR: SILICON PNP	
A2Q7	1853-0020	TRANSISTOR: SILICON PNP	
A2Q8	1854-0071	TRANSISTOR: SILICON NPN	
A2Q9	1854-0003	TRANSISTOR:NPN SILICON	
A2Q10	1853-0001	TRANSISTOR:PNP SILICON 30V 900MW	
A2Q11	1854-0071	TRANSISTOR: SILICON NPN	
A2Q12-		NOT ASSIGNED	
A2Q19		NOT ASSIGNED	
A2Q20	1853-0020	TRANSISTOR: SILICON PNP	
A2Q21	1854-0005	TRANSISTOR: SILICON NPN 2N708	
A2Q22	1854-0071	TRANSISTOR: SILICON NPN	
A2Q23	1854-0071	TRANSISTOR: SILICON NPN	
A2Q24	1854-0005	TRANSISTOR: SILICON NPN 2N708	
A2Q25		NOT ASSIGNED	
A2Q26	1854-0071	TRANSISTOR: SILICON NPN	
A2Q27	1854-0071	TRANSISTOR: SILICON NPN	
A2Q28	1854-0009	TRANSISTOR: SILICON NPN 2N709	
A2Q29	1854-0009	TRANSISTOR: SILICON NPN 2N709	
A2Q30	1855-0062	TRANSISTOR: FIELD EFFECT 30V	
A2Q31		NOT ASSIGNED	
A2Q32	1855-0062	TRANSISTOR:FIELD EFFECT 30V	
A2Q33		NOT ASSIGNED	
A2Q34	1854-0071	TRANSISTOR: SILICON NPN	
A2Q35	1854-0071	TRANSISTOR: SILICON NPN	
A2Q36	1853-0015	TRANSISTOR: SILICON PNP 2N3640	

See introduction to this section for ordering information

Table 6-1. Reference Designation Index (Cont'd)

Reference Designation	Part No.	Description #	Note
A2Q37	1853-0020	TRANSISTOR: SILICON PNP	
A2Q38	1855-0062	TRANSISTOR: FIELD EFFECT 30V	
A2Q39	1854-0071	TRANSISTOR: SILICON NPN	
A2Q40	1854-0071	TRANSISTOR: SILICON NPN	
A2Q41	1853-0020	TRANSISTOR: SILICON PNP	
A2Q42	1853-0020	TRANSISTOR: SILICON PNP	
A2Q43	1854-0071	TRANSISTOR: SILICON NPN	
A2Q44	1854-0071	TRANSISTOR: SILICON NPN	
A2R1	0757-0279	R: FXD MET FLM 3.16K OHM 1% 1/8W	
A2R2	0683-0685	R: FXD COMP 6.8 OHM 5% 1/4W	
A2R3	0757-0835	R: FXD MET FLM 6.81K OHM 1% 1/2W	
A2R4		NUT ASSIGNED	
A2R5	0698-3156	R: FXD MET FLM 14.7K OHM 1% 1/8W	
A2R6	2100-1773	R: VAR WW 1K OHM 10% LIN 1/2W	
A2R7	0757-0289	R: FXD MET FLM 13.3K OHM 1% 1/8W	
A2R8	0757-0280	R: FXD MET FLM 1K OHM 1% 1/8W	
A2R9	0698-3160	R: FXD MET FLM 31.6K OHM 1% 1/8W	
A2R10	0698-3441	R: FXD MET FLM 215 OHM 1% 1/8W FACTORY SELECTED PART	
A2R11	0757-0465	R: FXD MET FLM 100K OHM 1% 1/8W	
A2R12	0757-0442	R: FXD MET FLM 10.0K OHM 1% 1/8W	
A2R13	0698-3136	R: FXD MET FLM 17.8K OHM 1% 1/8W	
A2R14		NUT ASSIGNED	
A2R15	0757-0442	R: FXD MET FLM 10.0K OHM 1% 1/8W	
A2R16	0757-0279	R: FXD MET FLM 3.16K OHM 1% 1/8W	
A2R17	0757-0198	R: FXD MET FLM 100 OHM 1% 1/2W	
A2R18	0698-3401	R: FXD MET FLM 215 OHM 1% 1/2W	
A2R19		NUT ASSIGNED	
A2R20		NUT ASSIGNED	
A2R21	0698-3156	R: FXD MET FLM 14.7K OHM 1% 1/8W	
A2R22	0757-0442	R: FXD MET FLM 10.0K OHM 1% 1/8W	
A2R23	0757-0442	R: FXD MET FLM 10.0K OHM 1% 1/8W	
A2R24	0698-3260	R: FXD MET FLM 464K OHM 1% 1/8W	
A2R25	0698-3260	R: FXD MET FLM 464K OHM 1% 1/8W	
A2R26	0757-0442	R: FXD MET FLM 10.0K OHM 1% 1/8W	
A2R27	0757-0442	R: FXD MET FLM 10.0K OHM 1% 1/8W	
A2R28	0698-3156	R: FXD MET FLM 14.7K OHM 1% 1/8W	
A2R29	0757-0397	R: FXD MET FLM 68.1 OHM 1% 1/8W	
A2R30		NOT ASSIGNED	
A2R31		NUT ASSIGNED	
A2R32	0757-0199	R: FXD MET FLM 21.5K OHM 1% 1/8W	
A2R33	0757-0442	R: FXD MET FLM 10.0K OHM 1% 1/8W	
A2R34	0757-0465	R: FXD MET FLM 100K OHM 1% 1/8W	
A2R35	0698-3454	R: FXD MET FLM 215K OHM 1% 1/8W	
A2R36-		NOT ASSIGNED	
A2R37		NOT ASSIGNED	
A2R38	0757-0465	R: FXD MET FLM 100K OHM 1% 1/8W	
A2R39	0698-3155	R: FXD MET FLM 4.64K OHM 1% 1/8W	
A2R40	0698-3155	R: FXD MET FLM 4.64K OHM 1% 1/8W	
A2R41	0757-0465	R: FXD MET FLM 100K OHM 1% 1/8W	

See introduction to this section for ordering information

Table 6-1. Reference Designation Index (Cont'd)

Reference Designation	Part No.	Description #	Note
A2R42	0683-1065	R:FXD COMP 10M OHM 5% 1/4W	
A2R43	0757-1094	R:FXD MET FLM 1.47K OHM 1% 1/8W	
A2R44-		NOT ASSIGNED	
A2R45		NOT ASSIGNED	
A2R46	0757-0465	R:FXD MET FLM 100K OHM 1% 1/8W	
A2R47	0683-1065	R:FXD COMP 10M OHM 5% 1/4W	
A2R48-		NOT ASSIGNED	
A2R49		NOT ASSIGNED	
A2R50	0757-0280	R:FXD MET FLM 1K OHM 1% 1/8W	
A2R51	0698-3260	R:FXD MET FLM 464K OHM 1% 1/8W	
A2R52	0757-0279	R:FXD MET FLM 3.16K OHM 1% 1/8W	
A2R53	0698-3160	R:FXD MET FLM 31.6K OHM 1% 1/8W	
A2R54	0698-3428	R:FXD MET FLM 14.7 OHM 1% 1/8W	
A2R55	0698-3160	R:FXD MET FLM 31.6K OHM 1% 1/8W	
A2R56		FACTORY SELECTED PART NOT ASSIGNED	
A2R57	0757-0442	R:FXD MET FLM 10.0K OHM 1% 1/8W	
A2R58	0698-3260	R:FXD MET FLM 464K OHM 1% 1/8W	
A2R59	0698-3260	R:FXD MET FLM 464K OHM 1% 1/8W	
A2R60	0698-0084	R:FXD MET FLM 2.15K OHM 1% 1/8W	
A2R61	0683-1055	R:FXD COMP 1 MEGOHM 5% 1/4W	
A2R62-		NOT ASSIGNED	
A2R63		NOT ASSIGNED	
A2R64	0757-0439	R:FXD MET FLM 6.81K OHM 1% 1/8W	
A2R65	0757-0442	R:FXD MET FLM 10.0K OHM 1% 1/8W	
A2R66	0757-0461	R:FXD MET FLM 68.1K OHM 1% 1/8W	
A2R67	0698-3160	R:FXD MET FLM 31.6K OHM 1% 1/8W	
A2R68	0757-0442	R:FXD MET FLM 10.0K OHM 1% 1/8W	
A2R69	0698-3438	R:FXD MET FLM 147 OHM 1% 1/8W	
A2R70		NOT ASSIGNED	
A2R71	0698-3160	R:FXD MET FLM 31.6K OHM 1% 1/8W	
A2R72	0698-3444	R:FXD MET FLM 316 OHM 1% 1/8W	
A2R73	0757-0199	R:FXD MET FLM 21.5K OHM 1% 1/8W	
A2R74	2100-1769	R:VAR WW 50 OHM 10% LIN 1/2W	
A2R75	0698-4466	R:FXD MET FLM 976 OHM 1% 1/8W	
A2R76	0757-0346	R:FXD MET FLM 10 OHM 1% 1/8W	
A2R77	0698-3160	R:FXD MET FLM 31.6K OHM 1% 1/8W	
A2R78	0811-2277	R:FXD WW 10K OHM 0.1% 1/40W	
A2R79	0811-2277	R:FXD WW 10K OHM 0.1% 1/40W	
A2R80	0811-2537	R:FXD WW 5K OHM 0.1% 1/4W	
A2R81-		NOT ASSIGNED	
A2R82		NOT ASSIGNED	
A2R83	0698-3441	R:FXD MET FLM 215 OHM 1% 1/8W	
A2R84-		NOT ASSIGNED	
A2R86		NOT ASSIGNED	
A2R87	0683-1065	R:FXD COMP 10M OHM 5% 1/4W	
A2	0360-0124	TERMINAL:SOLDER LUG	
	0370-0077	KNOB:5/8" SKIRTED BAR	

See introduction to this section for ordering information

Table 6-1. Reference Designation Index (Cont'd)

Reference Designation	Part No.	Description #	Note
A3	00432-6003	SWITCH ASSY: RANGE	
A3R1	0811-2536	R:FXD WW 3167 OHM 0.1% 1/40W	
A3R2	0811-2284	R:FXD WW 1K OHM 0.1% 1/40W	
A3R3	0811-2534	R:FXD WW 314.3 OHM 0.1% 1/40W	
A3R4	0811-2535	R:FXD WW 145.0 OHM 0.1% 1/40W	
A3S1	3100-2470	SWITCH:ROTARY	
A4	00432-6004	SWITCH ASSY: CALIBRATION FACTOR	
A4R1	0757-0346	R:FXD MET FLM 10 OHM 1% 1/8W	
A4R2	0757-0346	R:FXD MET FLM 10 OHM 1% 1/8W	
A4R3	0757-0346	R:FXD MET FLM 10 OHM 1% 1/8W	
A4R4	0757-0346	R:FXD MET FLM 10 OHM 1% 1/8W	
A4R5	0757-0346	R:FXD MET FLM 10 OHM 1% 1/8W	
A4R6	0757-0346	R:FXD MET FLM 10 OHM 1% 1/8W	
A4R7	0757-0346	R:FXD MET FLM 10 OHM 1% 1/8W	
A4R8	0757-0346	R:FXD MET FLM 10 OHM 1% 1/8W	
A4R9	0757-0346	R:FXD MET FLM 10 OHM 1% 1/8W	
A4R10	0757-0346	R:FXD MET FLM 10 OHM 1% 1/8W	
A4R11	0757-0346	R:FXD MET FLM 10 OHM 1% 1/8W	
A4R12	0757-0346	R:FXD MET FLM 10 OHM 1% 1/8W	
A4R13	0698-6635	R:FXD MET FLM 880 OHM 1% 1/8W	
A4S1	3100-2469	SWITCH:ROTARY	
	0370-0193	KNOB:BLACK	
A5		NOT ASSIGNED	
A6		NOT ASSIGNED	
A7	00432-6007	BOARD ASSY:BATTERY CHARGER	
	00432-2007	BOARD:BLANK PC	
A7C1	0160-2930	C:FXD CER 0.01 UF +80-20% 100VDCW	
A7CR1	1901-0026	DIODE:SILICON 0.75A 200 PIV	
A7CR2	1902-0048	DIODE BREAKDOWN:6.81V 5%	
A7Q1	1854-0039	TRANSISTOR:SILICON 2N3053	
A7Q2	1853-0020	TRANSISTOR:SILICON PNP	
A7Q3	1854-0071	TRANSISTOR:SILICON NPN	
A7Q4	1854-0071	TRANSISTOR:SILICON NPN	
A7R1	0698-3635	R:FXD MET OX 680 OHM 5% 2W	
A7R2	0757-0280	R:FXD MET FLM 1K OHM 1% 1/8W	
A7R3	0757-0346	R:FXD MET FLM 10 OHM 1% 1/8W	
A7R4	0757-0439	R:FXD MET FLM 6.81K OHM 1% 1/8W	
A7R5	0757-0280	R:FXD MET FLM 1K OHM 1% 1/8W	
A7R6	0757-0199	R:FXD MET FLM 21.5K OHM 1% 1/8W	
A7R7	0757-0199	R:FXD MET FLM 21.5K OHM 1% 1/8W	
A7R8	2100-1775	R:VAR WW 5K OHM 10% LIN 1/2W	
BT1	1420-0062	BATTERY:RECHARGEABLE 24V	
BT1	00432-0008	BRACKET:BATTERY UPPER	
BT1	00432-0009	BRACKET:BATTERY LOWER	
C1	0160-3043	C:FXD CER 2 X 0.005 UF 20% 250VAC	

See introduction to this section for ordering information

Table 6-1. Reference Designation Index (Cont'd)

Reference Designation	Part No.	Description #	Note
DS1	2140-0015	LA MP:GLOW NEON NE- 2H	
F1	2110-0027	FUSE:0.125A 250V	
J1	1251-1280	CONNECTOR:AUDIO 6 FEMALE CONTACTS	
J2	1250-0118	CONNECTOR:BNC	
J2		V-RF	
J3	1250-0118	CONNECTOR:BNC	
J3		V-COMP	
J4	1250-0118	CONNECTOR:BNC	
J4		RECORDER OUT	
J5	1251-0148	CONNECTOR:POWER 3 PIN MALE	
M1	1120-1497	METER	
R1	2100-2849	R:VAR WW 50K OHM 5% LIN 1-1/2W(SERIAL PREFIX 904)	
R1	2100-2659	R:VAR WW 50K OHM 5% LIN 1-1/2W(SERIAL PREFIX 919)	
R2	0811-2538	R:FXD WW 100 OHM 0.1% 1/10W	
R3	0811-2538	R:FXD WW 100 OHM 0.1% 1/10W	
R4	0811-2538	R:FXD WW 100 OHM 0.1% 1/10W	
R5	0811-2538	R:FXD WW 100 OHM 0.1% 1/10W	
R6	0757-0198	R:FXD MET FLM 100 OHM 1% 1/2W	
R7	0757-0198	R:FXD MET FLM 100 OHM 1% 1/2W	
R8	0757-0198	R:FXD MET FLM 100 OHM 1% 1/2W	
R9	0698-3160	R:FXD MET FLM 31.6K OHM 1% 1/8W	
R10-		NUT ASSIGNED	
R13		NOT ASSIGNED	
R14	0811-2277	R:FXD WW 10K OHM 0.1% 1/40W	
S1	3101-0957	SWITCH:TOGGLE DPDT	
S1		POWER	
S2	3101-0033	SWITCH:SLIDE DPDT 0.5A 125V AC/DC	
S2		(115V/230V OPERATION)	
S3	3101-1180	SWITCH:SLIDE 3PDT	
S3		MOUNT RESISTANCE	
S3	7204-0004	ALUMINUM:SHEET 0.063 THICK	
S3	0590-0041	NUT:KNURLED 1-72 THREAD	
S4	3101-1357	SWITCH:TOGGLE SPDT	
S4		(FINE ZERO)	
T1	9100-2504	TRANSFORMER:28.4V SEC.	
T1	00432-0005	BRACKET:TRANSFORMER	
W1	8120-1082	CABLE ASSY:5 FT	
W2	8120-0078	CABLE ASSY:POWER CORD	
XA1	1251-0172	CONNECTOR:PRINTED CIRCUIT 22-CONN	
XA1		(PART OF 00432-0006 DECK LOWER)	
XA2	1251-0172	CONNECTOR:PRINTED CIRCUIT 22-CONN	
XDS1	5040-0257	LAMPHOLDER	
XDS1	5040-0235	BASE:LAMPHOLDER	
XF1	1400-0084	FUSEHOLDER: EXTRACTOR POST TYPE	

See introduction to this section for ordering information

Table 6-1. Reference Designation Index (Cont'd)

Reference Designation	Part No.	Description #	Note
	0403-0005	BUMPER: BLACK RUBBER	
	5020-0704 5040-0700 5040-0702	METER TRIM: THIRD MOD. HINGE INSULATOR: CONNECTOR	
	5040-4528	GUIDE: PC BOARD (GRAY PLASTIC)	
	00432-2003 00432-2004	NUT: DRESS BUSHING: PANEL	
	00432-2005	NUT: CONNECTOR	

See introduction to this section for ordering information

Table 6-1. Reference Designation Index (Cont'd)

Reference Designation	Part No.	Description #	Note
1.	5060-0703	FRAME ASSEMBLY	
2.	1490-0031	STAND:TILT	
3.	5040-0700	HINGE	
4.	5060-0727	FOOT ASSEMBLY	
5.	5020-0700	SPACER	
6.	5000-0703	SIDE COVER	
7.	5060-0706	COVER:TOP	
8.	5000-0711	COVER:BOTTOM	
9.	00432-0002	PANEL:REAR	
10.	00432-0001	PANEL:FRONT	

See introduction to this section for ordering information

Table 6-2. Replaceable Parts

Part No.	Description #	Mfr.	Mfr. Part No.	TQ
0140-0192	C:FXD MICA 68 PF 5%	28480	0140-0192	1
0140-0234	C:FXD MICA 500 PF 1%	28480	0140-0234	2
0150-0059	C:FXD CER 3.3-0.25 PF 500VDCW	72982	301-000-C0J0-339C	1
0160-0380	C:FXD MY 0.22 UF 10% 200VDCW	28480	0160-0380	2
0160-0978	C:FXD MICA 1500 PF 1% 500VDCW	28480	0160-0978	1
0160-2150	C:FXD MICA 33 PF 5%	28480	0160-2150	1
0160-2264	C:FXD CER 20 PF 5% 500VDCW	72982	301-000-C0G0-200J	2
0160-2672	C:FXD MY 0.047 UF 5% 80VDCW	28480	0160-2672	1
0160-2917	C:FXD CER 0.05 UF +80-20% 100VDCW	84411	TYPE TA	6
0160-2930	C:FXD CER 0.01 UF +80-20% 100VDCW	91418	TA	12
0160-3043	C:FXD CER 2 X 0.005 UF 20% 250VAC	56289	29C147A-CDH	1
0180-0106	C:FXD ELECT 60 UF 20% 6VDCW	28480	0180-0106	2
0180-0197	C:FXD ELECT 2.2 UF 10% 20VDCW	28480	0180-0197	3
0180-0229	C:FXD ELECT 33 UF 10% 10VDCW	28480	0180-0229	3
0180-0291	C:FXD ELECT 1.0 UF 10% 35VDCW	28480	0180-0291	1
0180-0374	C:FXD ELECT 10 UF 10% 20VDCW	28480	0180-0374	2
0180-1746	C:FXD ELECT 15 UF 10% 20VDCW	28480	0180-1746	1
0180-1819	C:FXD ELECT 100 UF +75-10% 50VDCW	28480	0180-1819	1
0180-1940	C:FXD ELECT 33 UF 10% 15VDCW	56289	109D336X9015C2-DYP	1
0180-2178	C:FXD ELECT 220 UF 20% 8VDCW	56289	109D227X0008F2-DYP	1
0360-0124	TERMINAL:SOLDER LUG	28480	0360-0124	17
0370-0077	KNOB:5/8 SK BAR	28480	0370-0077	1
0370-0193	KNOB:BLACK	28480	0370-0193	1
0403-0005	BUMPER:BLACK RUBBER	70485	#1059	1
0590-0041	NUT:KNURLED 1-72 THREAD	28480	0590-0041	1
0683-0685	R:FXD COMP 6.8 OHM 5% 1/4W	01121	CB68G5	1
0683-1055	R:FXD COMP 1 MEGOHM 5% 1/4W	01121	CB 1055	1
0683-1065	R:FXD COMP 10M OHM 5% 1/4W	01121	CB 1065	3
0686-1055	R:FXD COMP 1 MEGOHM 5% 1/2W	01121	EB 1055	1
0698-0084	R:FXD MET FLM 2.15K OHM 1% 1/8W	28480	0698-0084	1
0698-3136	R:FXD MET FLM 17.8K OHM 1% 1/8W	28480	0698-3136	2
0698-3155	R:FXD MET FLM 4.64K OHM 1% 1/8W	28480	0698-3155	2
0698-3156	R:FXD MET FLM 14.7K OHM 1% 1/8W	28480	0698-3156	5
0698-3160	R:FXD MET FLM 31.6K OHM 1% 1/8W	28480	0698-3160	14
0698-3260	R:FXD MET FLM 464K OHM 1% 1/8W	28480	0698-3260	7
0698-3401	R:FXD MET FLM 215 OHM 1% 1/2W	28480	0698-3401	1
0698-3428	R:FXD MET FLM 14.7 OHM 1% 1/8W	28480	0698-3428	1
0698-3438	R:FXD MET FLM 147 OHM 1% 1/8W	28480	0698-3438	1
0698-3441	R:FXD MET FLM 215 OHM 1% 1/8W	28480	0698-3441	4
0698-3444	R:FXD MET FLM 316 OHM 1% 1/8W	28480	0698-3444	1
0698-3454	R:FXD MET FLM 215K OHM 1% 1/8W	28480	0698-3454	1
0698-3635	R:FXD MET UX 680 OHM 5% 2W	28480	0698-3635	1
0698-4466	R:FXD MET FLM 976 OHM 1% 1/8W	28480	0698-4466	1
0698-6635	R:FXD MET FLM 880 OHM 1% 1/8W	28480	0698-6635	1
0757-0198	R:FXD MET FLM 100 OHM 1% 1/2W	28480	0757-0198	4
0757-0199	R:FXD MET FLM 21.5K OHM 1% 1/8W	28480	0757-0199	7
0757-0279	R:FXD MET FLM 3.16K OHM 1% 1/8W	28480	0757-0279	7
0757-0280	R:FXD MET FLM 1K OHM 1% 1/8W	28480	0757-0280	4
0757-0289	R:FXD MET FLM 13.3K OHM 1% 1/8W	28480	0757-0289	1
0757-0346	R:FXD MET FLM 10 OHM 1% 1/8W	28480	0757-0346	14
0757-0397	R:FXD MET FLM 68.1 OHM 1% 1/8W	28480	0757-0397	1
0757-0416	R:FXD MET FLM 511 OHM 1% 1/8W	28480	0757-0416	2
0757-0439	R:FXD MET FLM 6.81K OHM 1% 1/8W	28480	0757-0439	2
0757-0442	R:FXD MET FLM 10.0K OHM 1% 1/8W	28480	0757-0442	12

See introduction to this section for ordering information

Table 6-2. Replaceable Parts (Cont'd)

Part No.	Description #		Mfr. Part No.	TQ
0757-0461	R:FXD MET FLM 68.1K OHM 1% 1/8W	28480	0757-0461	3
0757-0465	R:FXD MET FLM 100K OHM 1% 1/8W	28480	0757-0465	9
0757-0835	R:FXD MET FLM 6.81K OHM 1% 1/2W	28480	0757-0835	1
0757-1094	R:FXD MET FLM 1.47K OHM 1% 1/8W	28480	0757-1094	1
0811-2277	R:FXD WW 10K OHM 0.1% 1/40W	28480	0811-2277	3
0811-2284	R:FXD WW 1K OHM 0.1% 1/40W	28480	0811-2284	5
0811-2534	R:FXD WW 314.3 OHM 0.1% 1/40W	28480	0811-2534	1
0811-2535	R:FXD WW 145.0 OHM 0.1% 1/40W	28480	0811-2535	1
0811-2536	R:FXD WW 3167 OHM 0.1% 1/40W	28480	0811-2536	1
0811-2537	R:FXD WW 5K OHM 0.1% 1/4W	28480	0811-2537	1
0811-2538	R:FXD WW 100 OHM 0.1% 1/10W	28480	0811-2538	4
1120-1497	METER	28480	1120-1497	1
1250-0118	CONNECTOR:BNC	28480	1250-0118	3
1251-0148	CONNECTOR:POWER 3 PIN MALE	87930	1065-1	1
1251-0172	CONNECTOR:PRINTED CIRCUIT 22-CONN	28480	1251-0172	2
1251-1280	CONNECTOR:AUDIO 6 FEMALE CONTACTS	28480	1251-1280	1
1400-0084	FUSEHOLDER:EXTRACTOR POST TYPE	79515	342014	1
1420-0062	BATTERY:RECHARGEABLE 24V	28480	1420-0062	1
1490-0031	STAND:TILT	28480	1490-0031	1
1853-0001	TRANSISTOR:PNP SILICON 30V 900MW	28480	1853-0001	3
1853-0012	TRANSISTOR:PNP SILICON 2N2904A	04713	2N2904A	1
1853-0015	TRANSISTOR:SILICON PNP 2N3640	28480	1853-0015	1
1853-0020	TRANSISTOR:SILICON PNP	28480	1853-0020	13
1854-0003	TRANSISTOR:NPN SILICON	28480	1854-0003	1
1854-0005	TRANSISTOR:SILICON NPN 2N708	02735	2N708	2
1854-0009	TRANSISTOR:SILICON NPN 2N709	07263	2N709	2
1854-0039	TRANSISTOR:SILICON 2N3053	02735	2N3053	1
1854-0062	TRANSISTOR:SILICON NPN 2N1701	02735	2N1701	1
1854-0071	TRANSISTOR:SILICON NPN	28480	1854-0071	22
1854-0221	TRANSISTOR DUAL:SILICON NPN	28480	1854-0221	2
1855-0062	TRANSISTOR:FIELD EFFECT 30V	28480	1855-0062	2
1901-0026	DIODE:SILICON 0.75A 200 PIV	28480	1901-0026	6
1901-0040	DIODE:SILICON 30MA 30WV	28480	1901-0040	16
1902-0033	DIODE BREAKDOWN:6.2V	04713	1N823	1
1902-0048	DIODE BREAKDOWN:6.81V 5%	28480	1902-0048	1
2100-1769	R:VAR WW 50 OHM 10% LIN 1/2W	28480	2100-1769	1
2100-1770	R:VAR WW 100 OHM 10% LIN 1/2W	28480	2100-1770	2
2100-1773	R:VAR WW 1K OHM 10% LIN 1/2W	28480	2100-1773	1
2100-1775	R:VAR WW 5K OHM 10% LIN 1/2W	28480	2100-1775	1
2100-2659	R:VAR WW 50K OHM 5% LIN 1-1/2W	28480	2100-2659	1
2100-2849	R:VAR WW 50K OHM 5% LIN 1-1/2W	28480	2100-2849	1
2110-0027	FUSE:0.125A 250V	75915	312.125	1
2140-0015	LAMP:GLOW NEON NE-2H.	24455	NE 2H	1
3100-2469	SWITCH:ROTARY	28480	3100-2469	1
3100-2470	SWITCH:ROTARY	28480	3100-2470	1
3101-0033	SWITCH:SLIDE DPDT 0.5A 125V AC/DC	79727	G326-0001	1
3101-0957	SWITCH:TOGGLE DPDT	28480	3101-0957	1
3101-1180	SWITCH:SLIDE 3PDT	82389	11L-1020	1
3101-1357	SWITCH:TOGGLE SPDT	09353	7109	1
5000-0703	SIDE COVER	28480	5000-0703	1
5000-0711	COVER:BOTTOM	28480	5000-0711	1
5020-0704	METER TRIM:THIRD MOD.	28480	5020-0704	1
5040-0235	BASE:LAMPHOLDER	28480	5040-0235	1
5040-0257	LAMPHOLDER	28480	5040-0257	1
5040-0700	HINGE	28480	5040-0700	1

See introduction to this section for ordering information

Table 6-2. Replaceable Parts (Cont'd)

Part No.	Description #	Mfr.	Mfr. Part No.	TQ
5040-0702	INSULATOR:CONNECTOR	28480	5040-0702	1
5040-4528	GUIDE:PC BOARD(GRAY PLASTIC)	28480	5040-4528	1
5060-C703	FRAME ASSY:6 X 11 SM	28480	5060-0703	1
5060-0706	COVER:TOP	28480	5060-0706	1
5060-0727	FOOT ASSY	28480	5060-0727	1
7204-0004	ALUMINUM:SHEET 0.063 THICK	28480	7204-0004	1
8120-0078	CABLE ASSY:POWER CORD	28480	8120-0078	1
8120-1082	CABLE ASSY:5 FT	28480	8120-1082	1
9100-2504	TRANSFORMER:28.4V SEC.	28480	9100-2504	1
00432-0001	PANEL:FRONT	28480	00432-0001	1
00432-0002	PANEL:REAR	28480	00432-0002	1
00432-0005	BRACKET:TRANSFORMER	28480	00432-0005	1
00432-0006	DECK:LOWER	28480	00432-0006	1
00432-0007	DECK:UPPER	28480	00432-0007	1
00432-0008	BRACKET:BATTERY UPPER	28480	00432-0008	1
00432-0009	BRACKET:BATTERY LOWER	28480	00432-0009	1
00432-2001	BOARD:BLANK PC	28480	00432-2001	1
00432-2003	NUT:DRESS	28480	00432-2003	1
00432-2004	BUSHING:PANEL	28480	00432-2004	1
00432-2005	NUT:CONNECTOR	28480	00432-2005	1
00432-2007	BOARD:BLANK PC	28480	00432-2007	1
00432-2015	BOARD:BLANK PC	28480	00432-2015	1
00432-6001	BOARD ASSY:BRIDGE	28480	00432-6001	1
00432-6003	SWITCH ASSY:RANGE	28480	00432-6003	1
00432-6004	SWITCH ASSY:CALIBRATION FACTOR	28480	00432-6004	1
00432-6007	BOARD ASSY:BATTERY CHARGER	28480	00432-6007	1
00432-6011	ASSY:AUTO ZERO	28480	00432-6011	1
00432-6015	BOARD ASSY:LOGIC	28480	00432-6015	1

See introduction to this section for ordering information

TABLE 6-3.
CODE LIST OF MANUFACTURERS

The following code numbers are from the Federal Supply Code for Manufacturers Cataloging Handbooks H4-1 (Name to Code) and H4-2 (Code to Name) and their latest supplements. The date of revision and the date of the supplements used appear at the bottom of each page. Alphabetical codes have been arbitrarily assigned to suppliers not appearing in the H4 Handbooks.

Code No.	Manufacturer	Address	Code No.	Manufacturer	Address	Code No.	Manufacturer	Address
00000	U. S. A. Common	Any supplier of U. S.	05397	Union Carbide Corp., Linde Div.	Kemet Dept. Cleveland, Ohio	11242	Bay State Electronics Corp.	Waltham, Mass.
00136	McCoy Electronics	Mount Holly Springs, Pa.	05593	Illumitronic Engineering Co	Sunnyvale, Calif.	11312	Teledyne Inc. Microwave Div.	Palo Alto, Calif.
00213	Sage Electronics Corp	Rochester, N. Y.	05616	Cosmo Plastic	(c/o Electrical Spec. Co.) Cleveland, Ohio	11314	National Seal	Downey, Calif.
00287	Cemco Inc.	Danielson, Conn.	05624	Barber Colman Co	Rockford, Ill	11534	Duncan Electronics Inc.	Costa Mesa, Calif.
00334	Humidial	Colton, Calif.	05728	Tiffen Optical Co	Roslyn Heights, Long Island, N. Y.	11711	General Instrument Corp., Semiconductor Div., Products Group	Newark, N. J.
00348	Microtron Co., Inc.	Valley Stream, N. Y.	05729	Metro-Tel Corp	Westbury, N. Y.	11717	Imperial Electronic, Inc.	Buena Park, Calif.
00373	Garlock Inc.	Cherry Hill, N. J.	05783	Stewart Engineering Co	Santa Cruz, Calif.	11870	Melabs, Inc.	Palo Alto, Calif.
00656	Aerovox Corp.	New Bedford, Mass.	05820	Wakefield Engineering Inc	Wakefield, Mass.	12136	Philadelphia Handle Co.	Camden, N. J.
00779	Amp Inc.	Harrisburg, Pa.	06004	Bassick Co., Div of Stewart Warner Corp.	Bridgeport, Conn	12361	Grove Mfg. Co., Inc.	Shady Grove, Pa.
00781	Aircraft Radio Corp	Boonton, N. J.	06090	Raychem Corp	Redwood City, Calif.	12574	Gulton Ind. Inc. Data System Div.	Albuquerque, N. M.
00815	Northern Engineering Laboratories, Inc.	Burlington, Wis.	06175	Bausch and Lomb Optical Co	Rochester, N. Y.	12697	Clarostat Mfg. Co.	Dover, N. H.
00853	Sangamo Electric Co., Pickens Div.	Pickens, S. C.	06402	E. T. A. Products Co of America	Chicago, Ill.	12728	Elmar Filter Corp.	W. Haven, Conn.
00866	Goe Engineering Co.	City of Industry, Cal.	06404	Amatom Electronic Hardware Co., Inc.	New Rochelle, N. Y.	12859	Nippon Electric Co., Ltd.	Tokyo, Japan
00891	Carl E. Holmes Corp.	Los Angeles, Calif.	06555	Beede Electrical Instrument Co., Inc.	Penacook, N. H.	12881	Metex Electronics Corp.	Clark, N. J.
00929	Microlab Inc.	Livingston, N. J.	06666	General Devices Co Inc.	Indianapolis, Ind	12930	Delta Semiconductor Inc.	Newport Beach, Calif.
01002	General Electric Co., Capacitor Dept.	Hudson Falls, N. Y.	06751	Semcor Div. Components Inc.	Phoenix, Ariz.	12954	Dickson Electronics Corp.	Scottsdale, Arizona
01009	Alden Products Co.	Brockton, Mass.	06812	Torrington Mfg Co., West Div.	Van Nuys, Calif	13103	Thermolloy	Dallas, Texas
01121	Allen Bradley Co.	Milwaukee, Wis.	06960	Varian Assoc. Eimac Div.	San Carlos, Calif.	13396	Telefunken (GmbH)	Hanover, Germany
02116	Litton Industries, Inc.	Beverly Hills, Calif.	07088	Kelvin Electric Co.	Van Nuys, Calif.	13835	Midland-Wright Div. of Pacific Industries, Inc.	Kansas City, Kansas
02128	TRW Semiconductors, Inc.	Lawndale, Calif.	07126	Digitaltron Co.	Pasadena, Calif.	14099	Sem-Tech	Newbury Park, Calif.
02195	Texas Instruments, Inc., Transistor Products Div	Dallas, Texas	07137	Transistor Electronics Corp.	Minneapolis, Minn.	14193	Calif. Resistor Corp.	Santa Monica, Calif.
03149	The Alliance Mfg. Co.	Alliance, Ohio	07138	Westinghouse Electric Corp. Electronic Tube Div	Elmira, N. Y.	14298	American Components, Inc.	Conshohocken, Pa.
03589	Pacific Relays, Inc.	Van Nuys, Calif.	07149	Filmohm Corp	New York, N. Y.	14433	ITT Semiconductor, A Div. of Int Telephone & Telegraph Corp.	West Palm Beach, Fla.
03930	Amerock Corp.	Rockford, Ill.	07233	Cinch Graphk Co	City of Industry, Calif.	14493	Hewlett-Packard Company	Loveland, Colo.
03961	Pulse Engineering Co.	Santa Clara, Calif.	07261	Avnet Corp	Culver City, Calif.	14655	Cornell Dublier Electric Corp.	Newark, N. J.
02114	Ferroxcube Corp. of America	Saugerties, N. Y.	07263	Fairchild Camera & Inst Corp Semiconductor Div.	Mountain View, Calif	14674	Corning Glass Works	Corning, N. Y.
02116	Wheelock Signals, Inc	Long Branch, N. J.	07322	Minnesota Rubber Co	Minneapolis, Minn	14752	Electro Tube Inc.	San Gabriel, Calif.
02286	Cole Rubber and Plastics Inc.	Sunnyvale, Calif.	07387	Birtcher Corp The	Monterey Park, Calif	14960	Williams Mfg. Co	San Jose, Calif.
02260	Amphenol-Boig Electronics Corp.	Chicago, Ill.	07397	Sylvania Elect Prod Inc. Mt. View Operations	Mountain View, Calif.	15203	Webster Electronics Co.	New York, N. Y.
02735	Radio Corp. of America, Semiconductor and Materials Div.	Somerville, N. J.	07700	Technical Wire Products Inc.	Cranford, N. J.	15287	Scionics Corp.	Northridge, Calif.
02771	Vocaline Co of America, Inc.	Old Saybrook, Conn.	07910	Continental Device Corp	Hawthorne, Calif	15291	Adjustable Bushing Co.	N. Hollywood, Calif.
02777	Hopkins Engineering Co.	San Fernando, Calif.	07933	Raytheon Mfg. Co Semiconductor Div.	Mountain View, Calif	15558	Micron Electronics	Garden City, Long Island, N. Y.
03508	G. E. Semiconductor Prod. Dept.	Syracuse, N. Y.	08145	U. S. Engineering Co.	Los Angeles, Calif.	15566	Amprobe Inst. Corp	Lynbrook, N. Y.
03705	Dayton Machine & Tool Co.	Dayton, Ohio	08289	Blinn, Delbert Co.	Pomona, Calif	15631	Cabletronics	Costa Mesa, Calif.
03797	Eldema Corp	Compton, Calif.	08358	Burgess Battery Co.	Niagara Falls, Ontario, Canada	15772	Twentieth Century Coil Spring Co.	Santa Clara, Calif.
03877	Transitron Electric Corp	Wakefield, Mass.	08524	Deutsch Fastener Corp.	Los Angeles, Calif.	15801	Fenwal Elect Inc.	Frammingham, Mass.
03888	Pyrofilm Resistor Co., Inc	Cedar Knolls, N. J.	08664	Bristol Co., The	Waterbury, Conn.	15818	Amelco Inc	Mt. View, Calif.
03954	Singer Co., Diehl Div. Finnerline Plant	Somerville, N. J.	08717	Sloan Company	Sun Valley, Calif.	16037	Spruce Pine Mica Co	Spruce Pine, N. C.
04009	Arrow, Hart and Hegeman Elect Co.	Hartford, Conn.	08718	iTT Cannon Electric Inc. Phoenix Div.	Phoenix, Arizona	16179	Omni-Spectra Inc.	Detroit, Ill.
04013	Taurus Corp.	Lambertville, N. J.	08792	CBS Electronics Semiconductor Operations, Div of C B S. Inc.	Lowell, Mass.	16352	Computer Diode Corp.	Lodi, N. J.
04062	Arco Electronic Inc.	Great Neck, N. Y.	08984	Mel-Rain	Indianapolis, Ind.	16688	Ideal Prec. Meter Co. Inc.	Brooklyn, N. Y.
04222	Hi-Q Division of Aerovox	Myrtle Beach, S. C.	09026	Babcock Relays Div	Costa Mesa, Calif.	16758	Delco Radio Div. of G. M. Corp.	Kokoma, Ind.
04354	Precision Paper Tube Co.	Wheeling, Ill.	09134	Texas Capacitor Co	Houston, Texas	17109	Thermonetics Inc	Canoga Park, Calif.
04404	Dymec Division of Hewlett-Packard Co	Palo Alto, Calif.	09145	Tech Ind Inc Atomh Elect.	Burbank, Calif.	17474	Tranex Company	Mountain View, Calif.
04651	Sylvania Electric Products, Microwave Device Div	Mountain View, Calif.	09250	Electro Assemblies, Inc.	Chicago, Ill	17675	Hamlin Metal Products Corp.	Akron, Ohio
04713	Motorola, Inc Semiconductor Prod. Div.	Phoenix, Arizona	09569	Mallory Battery Co. of Canada, Ltd.	Toronto, Ontario, Canada	17745	Angstrom Prec. Inc.	No Holly wood, Calif.
04732	Filttron Co., Inc. Western Div.	Culver City, Calif.	10214	General Transistor Western Corp	Los Angeles, Calif	17870	McGraw-Edison Co.	Manchester, N. H.
04773	Automatic Electric Co.	Northlake, Ill.	10411	Ti-Tal, Inc.	Berkeley, Calif.	18042	Power Design Pacific Inc	Palo Alto, Calif.
04796	Sequoia Wire Co	Redwood City, Calif.	10646	Carborundum Co	Niagara Falls, N. Y.	18083	Clevite Corp. Semiconductor Div.	Palo Alto, Calif.
04811	Precision Coil Spring Co	El Monte, Calif	11236	CTS of Berne, Inc	Berne, Ind	18324	Signetics Corp.	Sunnyvale, Calif.
04870	P. M. Motor Company	Westchester, Ill.	11237	Chicago Telephone of California, Inc.	So. Pasadena, Calif.	18476	Ty-Car Mfg Co., Inc	Holliston, Mass.
04919	Component Mfg. Service Co.	W. Bridgewater, Mass.				18486	TRW Elect Comp Div.	Des Plaines, Ill.
05006	Twentieth Century Plastics, Inc.	Los Angeles, Calif.				18583	Curtis Instrument, Inc.	Mt. Kisco, N. Y.
05277	Westinghouse Electric Corp. Semiconductor Dept	Youngwood, Pa.				18873	E. i. DuPont and Co., Inc.	Wilmington, Del.
05347	Ultronix, Inc	San Mateo, Calif.				18911	Durant Mfg. Co.	Milwaukee, Wis.
						19315	The Bendix Corp. Navigation & Control Div	Teterboro, N. J.
						19500	Thomas A Edison Industries, Div. of McGraw-Edison Co.	West Orange, N. J.
						19589	Concoa	Baldwin Park, Calif.
						19644	LORC Electronics	Horseheads, N. Y.
						19701	Electra Mfg Co.	Independence, Kansas

TABLE 6-3.
CODE LIST OF MANUFACTURERS (Cont'd)

Code No.	Manufacturer	Address	Code No.	Manufacturer	Address	Code No.	Manufacturer	Address
20183	General Atomics Corp.	Philadelphia, Pa	71436	Chicago Condenser Corp.	Chicago, Ill	77252	Philadelphia Steel and Wire Corp	Philadelphia, Pa.
21226	Executone, Inc	Long Island City, N. Y.	71447	Cal if Spring Co Inc	Pico-Rivera, Calif.			
21335	Fabrnr Bearing Co The	New Britain, Conn	71450	CTS Corp.	Eikhart, Ind.	77342	Ameri can Machi ne & Foundry Co Potter	Princeton, Ind
21520	Fansteel Metallurgical Corp	N. Chicago, Ill	71468	ITT Cannon Electric Inc.	Los Angeles, Calif.			
23783	British Radio Electronics Ltd	Washington, D C	71471	Cinema, Div Aerovox Corp.	Burbank, Calif.	77630	TRW Electronic Components Div	Camden, N J
24455	G E Lamp Division	Nela Park, Cleveland, Ohio	71482	C P Clare & Co	Chicago, Ill.	77638	General instrument Corp Rectifier Div	Brooklyn, N Y
24655	General Radi o Co	West Concord, Mass	71590	Centralab Div. of Globe Union Inc.		77764	Resistance Products Co	Torrance, Calif
24681	Memc of In c Com p. Div.	Huntington, Ind.	71616	Commercial Plastics Co.	Chicago, Ill.	77969	Rubbe rcraft Corp of Calif	Elgin, Ill.
26365	Gries Reproducer Corp.	New Rochelle, N Y.	71700	Cornish Wire Co The	New York, N. Y.	78189	Shake proof Division of Illinois Tool Works	New York, N. Y.
26462	Grobet File Co of America, Inc.	Carlstadt, N. J.	71707	Coto Coil Co Inc	Providence, R. I.			
26992	Hamilton Watch Co	Lancaster, Pa.	71744	Chicago Miniature Lamp Works	Chicago, Ill.	78283	Signal Indi cator Corp	Pitman, N. J.
28480	Hewlett Packard Co	Palo Alto, Calif.	71785	Cinch Mfg. Co., Howard B. Jones Div	Chicago, Ill.	78290	Struthers-Dunn Inc	Chicago, Ill
28520	Heyman Mfg Co.	Kenilworth, N. J.	71984	DowCo rningCorp.	Midland, Mich.	78452	Thompson-Bremer & Co	San Francisco, Calif
33173	G E Receiving Tube Dept.	Owensboro, Ky	72136	Electro Motive Mfg Co Inc.	Williamam ic, Conn.	78471	Triley Mfg Co	St Marys, Pa
35434	Lectrohm Inc	Chicago, Ill.	72519	Diallight Corp.	Brooklyn, N Y	78488	Stack pole Carbon Co	Waltham, Mass.
36196	Stanwyck Col l Products Ltd	Hawkesbury, Ontario, Canada	72656	Indiana General Corp., Electronics Div	Keasby, N. J.	78493	Standard Thomson Corp	Cleveland, Ohio
36287	Cunningham, W. H. & Hill, Ltd.	Toronto Ontario, Canada	72699	General Instrument Corp., Cap. Div.	Newark, N. J.	78790	Transformer Engineers	San Gabriel, Calif.
37942	P. R. Mallory & Co Inc	Indianapolis, Ind	72765	Drake Mfg. Co.	Harwood Heights, Ill.	78947	Ucinite Co	Newtonville, Mass
39543	Mechanical Industries Prod. Co.	Akron, Ohio	72785	Hugh H. Eby Inc.	Philadelphia, Pa	79136	Waldes Kohinoor Inc	Long Island City, N. Y.
40920	Miniature Precision Bearings, Inc.	Keene, N. H.	72928	Gudeman Co.	Chicago, Ill	79142	Weeder Root, Inc	Hartford, Conn
42190	Muler Co	Chicago, Ill	72964	Robert M. Hadley Co.	Los Angeles, Calif	79251	Wenco Mfg Co	Chicago, Ill
43990	C A. Norgren Co	Englewood, Colo	72982	Erie Technological Products, Inc	Erie, Pa	79727	Continental-Wirt Electronics Corp	Philadelphia, Pa.
44655	Ohmite Mfg Co	Skokie, Ill	73061	Hansen Mfg. Co., Inc.	Princeton, ind.	79963	Zierck Mfg Corp	New Rochelle, N. Y.
46384	Penn Eng & Mfg Corp.	Doylestown, Pa.	73076	H. M. Harper Co.	Chicago, Ill.	80031	Mecco Division of Sessions Clock Co	Morristown, N. J
47904	Polaroid Corp	Cambridge, Mass	73138	Helipot Div of Beckman Inst., Inc	Fullerton, Calif	80120	Schnitzer Alloy Products Co	Elizabeth, N. J
48620	Precision Thermometer & Inst Co.	Southampton, Pa	73293	Hughes Products Division of Hughes Aircraft Co.	Newport Beach, Calif	80131	Electronic Industries Association, Any brand Tube meeting EIA Standards-Washington, DC	Any brand
49556	Microwave & Power Tube Div	Waltham, Mass.	73445	Ampetex Elect Co.	Hicksville, L I N. Y.	80207	Unimax Switch Div Maxon Electronics Corp	Wallingford, Conn
52090	Rowan Controller Co	Westminster, Md.	73506	Bradley Semiconductor Corp.	New Haven, Conn	80223	United Transformer Corp	New York, N. Y.
52983	Sanborn Company	Waltham, Mass.	73559	Carling Electric, Inc	Hartford, Conn	80248	Oxford Electric Corp	Chicago, Ill
54294	Shall cross Mfg Co	Selma, N. C	73586	Circle F Mfg. Co.	Trenton, N. J.	80294	Bourns Inc	Riverside, Calif
55026	Simpson Electric Co	Chicago, Ill	73682	George K Garrett Co., Div. MSL Industries Inc.	Philadelphia, Pa.	80411	Acro Div of Robertshaw Controls Co	Columbus, Ohio
55933	Sonotone Corp	Elmsford, N. Y.	73734	Federal Screw Products Inc.	Chicago, Ill	80486	All Star Products Inc.	Defiance, Ohio
55938	Raytheon Co Commercial Apparatus & Systems Div	So Norwalk, Conn.	73743	Fischer Special Mfg. Co	Cincinnati, Ohio	80509	Avery Label Co	Monrovia, Calif
56137	Spaulding Fibre Co Inc	Tonawanda, N. Y.	73793	General Industries Co The	Elyria, Ohio	80583	Hammillund Co Inc	New York, N. Y.
56289	Sprague Electric Co	North Adams, Mass.	73846	Goshen Stamping & Tool Co.	Goshen, Ind	80640	Stevens, Arnold, Co Inc	Boston, Mass
59446	Telex Corp	Tulsa, Okla.	73899	JFD Electronics Corp.	Brooklyn, N. Y.	81030	International Instruments Inc	Orange, Conn.
59730	Thomas & Betts Co	Elizabeth, N. J.	73905	Jennings Radio Mfg Corp	San Jose, Calif	81073	Grayhill Co	LaGrange, Ill
60741	Triplett Electrical Inst. Co	Bluffton, Ohio	73957	Groov-Pin Corp.	Ridgefield, N. J.	81095	Triad Transformer Corp	Venice, Calif.
61775	Uni on Swi tch and Signal, Div of Westinghouse Air Brake Co	Pittsburgh, Pa.	74276	Signalite Inc	Neptune, N. J	81312	Winchester Elec Div. Litton Ind Inc	Oakville, Conn.
62119	Universal Electric Co	Owosso, Mich.	74455	J. H. Winns, and Sons	Winchester, Mass	81349	Military Specification	
63743	Ward-Leonard Electric Co	Mt Vernon, N. Y.	74861	Industrial Condenser Corp	Chicago, Ill	81483	International Rectifier Corp	El Segundo, Calif.
64959	Western Electric Co Inc	New York, N. Y.	74868	R F Products Division of Amphenol-Borg Electronics Corp	Danbury, Conn	81541	Airpa x Electronics, Inc	Cambridge, Maryland
65092	Weston Inst Inc Weston-Newark	Newark, N. J.	74970	E. F. Johnson Co	Waseca, Minn	81860	Barry Controls Div. Barry Wright Corp	Watertown, Mass.
66295	Witteck Mfg Co.	Chicago, Ill	75042	International Resistance Co	Philadelphia, Pa	82042	Carter Precision Electric Co	Skokie, Ill.
66346	Minnesota Mining & Mfg Co. Revere	Mincom Div. St Paul, Minn.	75378	CTS Knights Inc.	Sandwich, Ill	82047	Sperit Faraday Inc Copper Hewitt Electric Div	Hoboken, N. J.
70276	Allen Mfg Co	Hartford, Conn.	75382	Kulka Electric Corporation	Mt Vernon, N. Y.	82142	Jeffers Electronics Division of Speer Carbon Co	Du Bois, Pa
70309	Allied Control	New York, N. Y.	75818	Lenz Electric Mfg Co.	Chicago, Ill.	82170	Fairchild Camera & Inst. Corp. Space & Defense System Div	Paramus, N. J.
70318	Allmetal Screw Product Co Inc	Garden City, N. Y.	75915	Littlefuse, Inc	Des Plaines, Ill	82209	Maguire Industries, Inc	Greenwich, Conn
70485	Atlantic India Rubber Works, Inc	Chicago, Ill.	76005	Lord Mfg Co.	Erie, Pa	82219	Sylvania Electric Prod Inc Electronic Tube Division	Emporium, Pa
70563	Amperite Co Inc	Union City, N. J.	76210	C W Marwedel	San Francisco, Calif	82376	Astron Corp	East Newark, Harrison, N. J.
70674	ADC Products Inc.	Minneapolis, Minn.	76433	General Instrument Corp., Micamold Division	Newark, N. J.	82389	Switchcraft, Inc	Chicago, Ill.
70903	Belden Mfg Co	Chicago, Ill.	76487	James Millen Mfg Co., Inc.	Malden, Mass.	82647	Metals & Controls Inc. Spencer Products	Attleboro, Mass.
70998	Bird Electronic Corp	Cleveland, Ohio	76493	J. W. Miller Co.	Los Angeles, Calif.	82768	Phillips-Advance Control Co	Joliet, Ill.
71002	Birnback Radio Co.	New York, N. Y.	76530	Cinch Monadnock, Div. of United Carr Fastener Corp.	San Leandro, Calif	82866	Research Products Corp.	Madison, Wis.
71041	Boston Gear Works Div of Murray Co. of Texas	Quincy, Mass	76530	Cinch Monadnock, Div. of United Carr Fastener Corp.	San Leandro, Calif	82877	Rotron Mfg Co Inc.	Woodstock, N. Y.
71218	Bud Radio, Inc.	Willoughby, Ohio	76545	Mueller Electric Co	Cleveland, Ohio	82893	Vector Electronic Co	Glendale, Calif.
71286	Camloc Fastener Corp	Paramus, N. J.	76703	National Union	Newark, N. J.			
71313	Cardwell Condenser Corp.	Lindenhurst L. I., N. Y.	76854	Oak Manufacturing Co.	Crystal Lake, Ill			
71400	Bussmann Mfg. Div. of McGraw-Edison Co	St. Louis, Mo.	77068	The Bendix Corp Electrodynamics Div.	N. Hollywood, Calif			
			77075	Pacific Metals Co	San Francisco, Calif			
			77221	Phanotron Instrument and Electronic Co.	South Pasadena, Calif.			

TABLE 6-3.
CODE LIST OF MANUFACTURERS (Cont'd)

Code No.	Manufacturer	Address	Code No.	Manufacturer	Address	Code No.	Manufacturer	Address
83056	Carr Fastener Co.	Cambridge, Mass.	91418	Radio Materials Co.	Chicago, Ill.	97464	Industrial Retaining Ring Co	Irvington, N. J.
83086	New Hampshire Ball Bearing, Inc.	Peterborough, N. H.	91506	Augat Inc.	Attleboro, Mass.	97539	Automatic & Precision Mfg.	Englewood, N. J.
83125	General Instrument Corp Capacitor Div.	Darlington, S. C.	91637	Dale Electronics, Inc.	Columbus, Nebr.	97979	Reon Resistor Corp.	Yonkers, N. Y.
83142	ITT Wire and Cable Div	Los Angeles, Calif.	91662	Elco Corp	Willow Grove, Pa.	97983	Litton System Inc. Adler-Westrex Commun. Div.	New Rochelle, N. Y.
83186	Victory Eng. Corp.	Springfield, N. J.	91737	Greiner Mfg. Co., Inc.	Wakefield, Mass.	98141	R-Tronics, Inc.	Jamaica, N. Y.
83298	Bendix Corp Red Bank Div	Red Bank, N. J.	91827	KF Development Co	Redwood City, Calif.	98159	Rubber Teck, Inc.	Gardena, Calif.
83315	Hubbell Corp.	Mundelein, Ill.	91886	Malco Mfg. Co., Inc.	Chicago, Ill.	98220	Hewlett-Packard Co., Moseley Div.	Pasadena, Calif.
83330	Smith, Herman H. Inc.	Brooklyn, N. Y.	91929	Honeywell Inc Micro Switch Div.	Freeport, Ill.	98278	Microdot, Inc.	So. Pasadena, Calif.
83337	Tech Labs	Palisades Park, N. J.	92180	Tru-Connector Corp.	Peabody, Mass.	98291	Sealectro Corp.	Mamaroneck, N. Y.
83385	Central Screw Co.	Chicago, Ill.	92367	Eigeel Optical Co Inc.	Rochester, N. Y.	98376	Zero Mfg. Co.	Burbank, Calif.
83501	Gavitt Wire and Cable Co. Div. of Amerace Corp.	Brookfield, Mass.	92607	Tensolite Insulated Wire Co., Inc.	Tarrytown, N. Y.	98731	General Mills Inc., Electronics Div.	Minneapolis, Minn.
83740	Burroughs Corp. Electronic Tube Div.	Plainfield, N. J.	92702	IMC Magnetics Corp.	Wesbury Long Island, N. Y.	98734	Paeco Div. of Hewlett-Packard Co.	Palo Alto, Calif.
83777	Model Eng and Mfg., Inc	New York, N. Y.	92966	Hudson Lamp Co.	Kearney, N. J.	98821	North Hills Electronics, Inc.	Glen Cove, N. Y.
83821	Loyd Scuggs Co	Huntington, Ind.	93332	Sylvania Electric Prod. Inc. Semiconductor Div	Woburn, Mass.	98978	International Electronic Research Corp.	Burbank, Calif.
83942	Aeronautical Inst. & Radio Co.	Festus, Mo.	93369	Robbins & Myers Inc	Palisades Park, N. J.	99109	Columbia Technical Corp.	New York, N. Y.
84171	Arco Electronics Inc.	Lodi, N. J.	93410	Stevens Mfg. Co Inc	Mansfield, Ohio	99313	Varian Associates	Palo Alto, Calif.
84396	A. J. Glesener Co., Inc.	Great Neck, N. Y.	93929	G. V. Controls	Livingston, N. J.	99378	Altee Corp.	Winchester, Mass.
84411	TRW Capacitor Div	San Francisco, Calif.	94137	General Cable Corp.	Bayonne, N. J.	99515	Marshall Ind., Capacitor Div.	Monrovia, Calif.
84970	Sarkes Tarzian, Inc	Ogallala, Neb.	94144	Raytheon Co Comp. Div., Ind. Comp. Operations	Quincy, Mass.	99707	Control Switch Division, Controls Co. of America	El Segundo, Calif.
85454	Boonton Molding Company	Bloomington, Ind.	94148	Scientific Electronics Products, Inc	Quincy, Mass.	99800	Delevan Electronics Corp.	East Aurora, N. Y.
85474	A. B. Boyd Co.	Boonton, N. J.	94154	Wagner Elect. Corp. Tung-Sol Div.	Loveland, Colo.	99848	Wilco Corporation	Indianapolis, Ind.
85660	R. M. Bracamonte & Co.	San Francisco, Calif.	94197	Curtiss-Wright Corp. Electronics Div.	Newark, N. J.	99934	Renbrandt, Inc.	Boston, Mass.
85911	Koiled Kords, Inc.	San Francisco, Calif.	94222	South Chester Corp	East Paterson, N. J.	99942	Hoffman Electronics Corp. Semiconductor Div.	El Monte, Calif.
86197	Seamless Rubber Co.	Hamden, Conn.	94330	Wire Cloth Products, Inc.	Chester, Pa.	99957	Technology Instrument Corp of Calif.	Newbury Park, Calif.
86579	Clifton Precision Products Co., Inc.	Chicago, Ill.	94682	Worcester Pressed Aluminum Corp.	Bellwood, Ill.			
86684	Precision Rubber Products Corp.	Clifton Heights, Pa.	94696	Magnecraft Electric Co	Worcester, Mass.			
87034	Radio Corp. of America, Electronic Comp. & Devices Div.	Dayton, Ohio	95023	George A Philbrick Researchers, Inc	Chicago, Ill.			
87216	Marco Industries	Harrison, N. J.	95236	Allies Products Corp	Boston, Mass.			
87473	Philco Corporation (Lansdale Division)	Anaheim, Calif.	95238	Continental Connector Corp.	Dania, Fla.			
87664	Western Fibrous Glass Products Co	Lansdale, Pa.	95263	Leecraft Mfg. Co. Inc.	Woodside, N. Y.			
87930	Van Waters & Rogers Inc.	San Francisco, Calif.	95265	National Coil Co	Long Island, N. Y.			
88140	Tower Mfg. Corp.	San Francisco, Calif.	95275	Vitramon, Inc	Sherridan, Wyo.			
88140	Cuttler-Hammer, Inc.	Providence, R. I.	95348	Gordos Corp.	Bridgeport, Conn.			
88220	Gould-National Batteries, Inc.	Lincoln, Ill.	95354	Methode Mfg. Co.	Bloomfield, N. J.			
88698	General Mills, Inc.	St. Paul, Minn.	95566	Arnold Engineering Co.	Rolling Meadows, Ill.			
89231	Graybar Electric Co	Buffalo, N. Y.	95712	Dage Electric Co., Inc.	Marengo, Ill.			
89473	G. E. Distributing Corp.	Oakland, Calif.	95984	Siemon Mfg. Co.	Franklin, Ind.			
89665	United Transformer Co.	Schenectady, N. Y.	95987	Weckesser Co.	Wayne, Ill.			
90179	US Rubber Co. Consumer Ind. & Plastics Prod. Div.	Chicago, Ill.	96067	Huggins Laboratories	Chicago, Ill.			
90970	Bearing Engineering Co.	Passaic, N. J.	96095	Hi-Q Div. of Aerovox Corp.	Sunnyvale, Calif.			
91146	ITT Cannon Elect. Inc.	San Francisco, Calif.	96256	Thordarson-Meissner Inc.	Olean, N. Y.			
91260	Connor Spring Mfg. Co.	Salem Div. Salem, Mass.	96296	Solar Manufacturing Co.	Mt. Carmel, Ill.			
91345	Miller Dial & Nameplate Co	San Francisco, Calif.	96330	Carlton Screw Co.	Los Angeles, Calif.			
		El Monte, Calif.	96341	Microwave Associates, Inc.	Chicago, Ill.			
			96501	Excel Transformer Co.	Burlington, Mass.			
					Oakland, Calif.			

THE FOLLOWING HP VENDORS HAVE NO NUMBER ASSIGNED IN THE LATEST SUPPLEMENT TO THE FEDERAL SUPPLY CODE FOR MANUFACTURERS HANDBOOK.

0000F	Malco Tool and Die	Los Angeles, Calif.
0000Z	Willow Leather Products Corp.	Newark, N. J.
000AB	ETA	England
000BB	Precision Instrument Components Co.	Van Nuys, Calif.
000CS	Hewlett-Packard Co. Colorado Springs	Colorado Springs, Colorado
000MM	Rubber Eng. & Development	Hayward, Calif.
000NN	A "N" D Mfg. Co.	San Jose, Calif.
000QQ	Coaltron	Oakland, Calif.
000WW	California Eastern Lab.	Burlington, Calif.
000YY	S. K. Smith Co.	Los Angeles, Calif.

SECTION VII TROUBLESHOOTING, SCHEMATICS, AND COMPONENT LOCATIONS

7-1. INTRODUCTION.

7-2. This section contains troubleshooting instructions, schematics, and component locations for the power meter. Also included is an overall block diagram that indicates the location of test points in the instrument.

7-3. Reference designations shown within circuit card outlines are abbreviated. To find the part in the Parts List, use the full reference designation. For example, R6 on the A2 Meter Logic Assembly is listed as A2R6.

7-4. The Schematic Notes in Table 7-1 pertain to all the schematics. Additional notes on the schematics indicate test conditions, and special information for use when maintaining the instrument.

7-5. TROUBLESHOOTING.

7-6. Table 7-2 is the Overall Troubleshooting chart for the power meter. Procedures for isolating circuit malfunctions to specific stages are based on the use of the HP 8477A Power Meter Calibrator and the calibration procedures in Section V. The information obtained when calibration is attempted is used to troubleshoot the instrument.

7-7. Table 7-2 contains references that direct the user to the detailed troubleshooting charts, Tables 7-3 through 7-11. The detailed charts refer the user to transistor stages. In a few instances, specific parts are called out as being possible causes of circuit malfunction, however, the troubleshooting charts are not intended to locate specific parts that have failed. They are intended to locate only malfunctioning stages.

7-8. SCHEMATICS.

7-9. The schematics contain signal routing information, nominal voltage levels, and notes that assist in understanding the circuit. They are laid out to show electrical operation, and are not intended as wiring diagrams.

7-10. Component location photographs next to the schematic foldouts indicate the physical location of parts. Test points are also shown, and are marked on the schematic in the same manner as they are in the meter.

7-11. Factory selected parts are indicated by an asterisk. These are components that generally are installed to fulfill circuit operation requirements. They may be the nominal value, or they may be some value close to nominal. In any case, if the component fails, circuit operation should be verified after these components are replaced.

7-12. AIAI AUTO ZERO ASSEMBLY.













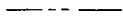

7-13. The Auto Zero circuit is encapsulated and must be replaced as a unit. A solder removing tool, such as the Soldapullit suction device listed in Section V, is required to remove solder around the leads. After solder is removed, the unit must be carefully removed from the circuit card in such a manner that the circuits on the card do not delaminate. After the Auto Zero assembly is replaced, perform the adjustment procedure given in Section V.

7-14. TEST CONDITIONS.

7-15. For most tests of circuit operation when troubleshooting the instrument, the troubleshooting charts call out control settings. In special cases, notes on the schematics indicate control settings required to measure voltage levels in circuits. Generally, the following control settings should be selected, and changed only as the troubleshooting procedures indicate:

- Raffle3 mW (-5 dBm)
- MOUNT RESISTANCE200 (Mount installed)
- CALIBRATION FACTOR100
- COARSE ZERO turn until meter is at full scale

Table 7-1. Schematic Notes

1.		Resistance in ohms, capacitance in microfarads unless otherwise indicated.
2.		Screwdriver adjustment
		Front panel control
3.		Front panel designation
		Rear panel designation
4.		Printed circuit card border
		Main signal path
		Secondary signal path
		Secondary feedback path
5.		P/O = part of
6.		Wiper moves toward CW when control rotated clockwise
7.		Test point. Number in circle matches number on printed circuit card.
8.		Breakdown diode
9.		Tunnel diode
10.		Wire color code. Numerical color code same as resistor coding. For example, 947 denotes white, yellow, violet wire.
11.		Indicates socket connections and pin numbers.



THERMISTOR MOUNT

478A

HP Model 478A Thermistor Mount

GENERAL INFORMATION

1. INTRODUCTION.

2. The HP Model 478A Coaxial Thermistor Mount is designed for use with HP Model 431 and 432 Power Meters to measure microwave power from $1\mu\text{W}$ to 10 mW. Design of the mount minimizes adverse effects from environmental temperature changes during measurement. For increased measurement accuracy, Effective Efficiency and Calibration Factor are measured for each mount, and at selected frequencies across the operating range; the results are marked on the label of the instrument (see Paragraph 31). The Model 478A can be used over the 10-MHz to 10-GHz frequency range. Through-

out the range, the mount terminates the coaxial input in a 50-ohm impedance, and has a SWR of not more than 1.75 without external tuning.

3. Each mount contains two series pairs of thermistors, which are matched to cancel the effects of drift with ambient temperature change. Thermal stability is accomplished by mounting the leads of all four thermistors on a common thermal conductor to ensure a common thermal environment. This conductor is thermally insulated from the main body of the mount so the thermal noise or shocks applied externally to the mount, such as those from handling the mount manually, cannot significantly penetrate to disturb the thermistor. This thermal immunity enables the thermistors to be used in the

Table 1. Specifications

frequency Range: 478A: 10 MHz to 10 GHz

Mount Calibration: Calibration Factor and Effective Efficiency furnished at six frequencies between 10 MHz and 10 GHz.

Impedance: 50 ohms.

Maximum Reflection Coefficient:
 10 to 25 MHz: 0.273 (1.75 SWR, 11.3 dB return loss).
 25 MHz to 7 GHz: 0.13 (1.3 SWR, 17.7 dB return loss).
 7 to 10 GHz: 0.2 (1.5 SWR, 14 dB return loss)

Operating Resistance: 200 ohms.

Power Range with Model 431 and 432A: 1 μ W to 10 mW.

Maximum Peak Power: 200W.

Maximum Average Power: 30 mW.

Maximum Energy per Pulse: 10 W \cdot μ s for a PRF \geq 1 kHz; 5 W \cdot μ s for a PRF < 1 kHz.

Elements: Field-replaceable, thermally balanced thermistor assembly. Thermistor assembly field adjustable so that full "zero-set" capability can be restored in the event of inadvertent overload (mount calibration no longer valid).

RF Connector: Type -N male, compatible with female connectors whose dimensions conform to MIL-C-71 or MIL-C-39012. Brass connector.

Output Connector: Mates with 431 and 432 cables.

Weight: Net, 5 oz (140 g). Shipping, 1 lb (450 g).

Uncertainty of Calibration Factor and Effective Efficiency Data for 478A

Sum Freq. (GHz)	Uncertainties (%)		Probable Uncertainties (%)	
	Cal. Factor	Effective Efficiency	Cal. Factor	Effective Efficiency
1.0	2.3	2.3	1.1	1.1
3.0	2.8	3.1	1.6	1.6
5.0	3.6	3.5	2.1	2.1
7.0	3.7	4.1	2.1	2.1
8.2	2.8	3.5	1.3	1.3
9.8	2.8	3.1	1.3	1.3
12.4	6.3	4.6	2.1	1.6
15.0	6.3	4.6	2.1	1.6
18.0	6.3	4.8	2.1	1.6

*Includes uncertainty of reference standard and transfer uncertainty. Directly traceable to NBS. In addition to the listed uncertainties, add the following for the indicated 431 ranges: 0.3% ; 0.1 mW, \pm 0.7% ; 0.03 mW, \pm 1.5% ; 0.01 mW. When using the 432 Power Meter no additional uncertainties are encountered.

measurement of microwave power down to the micro-watt region.

4. INCOMING INSPECTION.

5. Inspect the Model 478A upon receipt for mechanical damage. Also check it electrically; if the mount was subjected to severe mechanical shock during shipment, the match between the thermistors may be affected. To check thermistor match, proceed as described in Paragraph 58.

6. If any damage is found, inform the carrier and your nearest HP Sales and Service Office immediately.

OPERATION

7. PRECAUTIONS.

8. MECHANICAL SHOCK

9. DO NOT DROP OR SUBJECT TO SEVERE MECHANICAL SHOCK. SHOCK MAY DESTROY THE MATCH BETWEEN THERMISTORS AND INCREASE SUSCEPTIBILITY TO DRIFT.

10. BIASING THERMISTORS.

CAUTION

Before connecting the Model 478A to the 431 or 432 Power Meters, set the MOUNT RES switch to 200-ohm position. CONNECTING A 200-OHM MOUNT TO A POWER METER SET FOR A 100-OHM MOUNT CAN RESULT IN THERMISTOR DAMAGE.

11. MAXIMUM INPUT.

12. The Model 478A 431 and 478A 432 combinations respond to the average RF power applied. The maximum signal applied to the thermistor mount should not exceed the limitations for 1) average power, 2) pulse energy and 3) peak pulse power. Excessive input can permanently damage the Model 478A by altering the match between the RF and compensation thermistors (resulting in excessive drift or zero shift) or cause error in indicated power.

13. AVERAGE POWER. The 478A 431 and 478A 432 combinations can measure average power up to 10 mW. To measure power in excess of 10 mW, insert a calibrated directional coupler such as one of the HP Model 770 series or 790 series between the mount and the source. UNDER NO CIRCUMSTANCES APPLY MORE THAN 30 mW AVERAGE POWER TO THE MOUNT.

14. PULSE ENERGY AND PEAK POWER FOR 478A 432 COMBINATION. For pulses shorter than 250 μ s, energy per pulse must not exceed 10 W- μ s and peak power should never exceed 200 watts. (For example, a 40 mW, 250 μ s pulse contains 10 W- μ s of energy.) Pulses longer than 250 μ s are allowed to contain more energy but peak power must not exceed 40 mW. Figures 1 and 2 interpret these limits in graphical form. (For lack of space, the mount nameplate lists only a 5 W- μ s

Model 478A

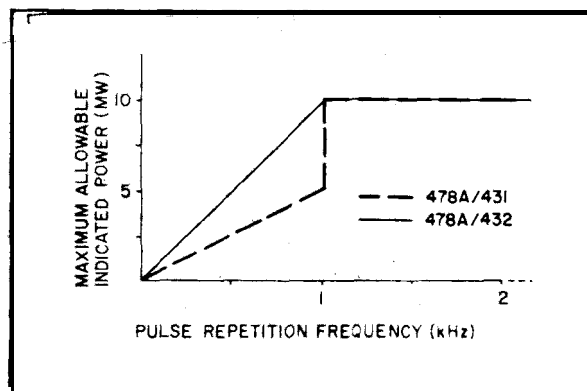

Figure 1. Maximum Power Meter Reading vs PRF for Pulses Shorter than 250 μ s

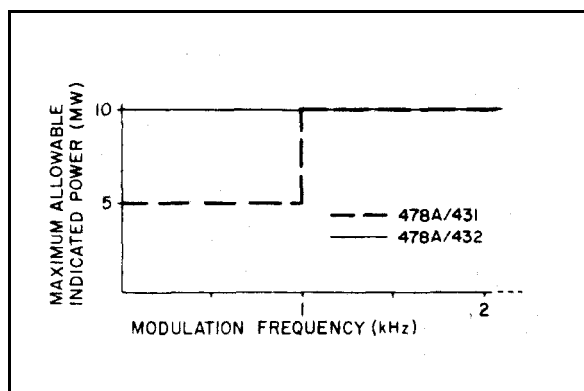

Figure 3. Maximum Power Meter Reading vs Square and Sine -Wave Frequency

limit, a rating which applies to the 478A 431 combination.)

15. PULSE ENERGY AND PEAK POWER FOR 478A/431 COMBINATION. The limitations of this combination are basically the same as the 478A 432 with the exception that at pulse repetition rates less than 1 kHz, energy per pulse must not exceed 5 W-U's and peak power must not exceed 10 mW. These limits are also interpreted in Figures 1 and 2.

16. Square-wave modulation is a special case of pulse modulation, and maximum power-meter reading versus square -wave frequency is illustrated in Figure 3. This figure also holds for sine -wave modulation.

17. In the discussions above, the primary consideration is maximum power or energy. However, for modulation frequencies less than 100 Hz, the low repetition frequency itself causes errors in indicated power. These errors may be as large as two percent regardless of range or reading.

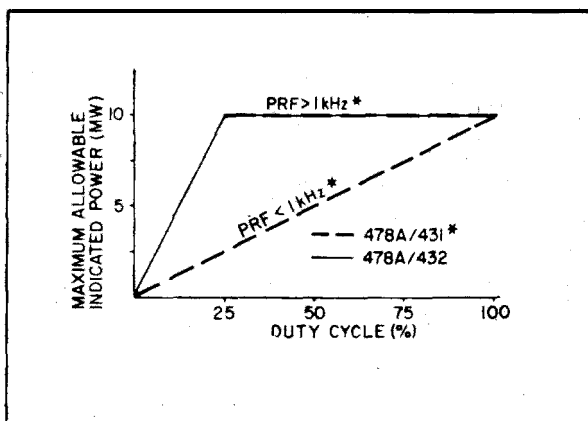

Figure 2. Maximum Power Meter Readings vs Duty Cycle for Pulses Longer than 250 μ s

18. When RF is switched by pulse-gating (coaxial solid state switches), consideration must be given to the RF energy contained in the switching pulse itself. This energy must be added to actual RF pulse power when estimating the RF power dissipated in the thermistor mount. PIN diode modulators of H P Model 8741A/8716A Modulators and 8614A/8616A Signal Generators, however, are not subject to this consideration because output filtering prevents transmission of modulating signals.

19. DRIFT PRECAUTION.

20. Thermistors are inherently temperature -sensitive devices, A cold thermistor mount connected to a warm piece of equipment, or vice versa, produces rapid drift. FOR MINIMUM DRIFT ON SENSITIVE RANGES, MAKE SURE THAT THE MOUNT AND THE EQUIPMENTCONNECTED TO IT ARE AT NEARLY THE SAME TEMPERATURE BEFORE MAKING A MEASUREMENT.

21. ZERO-SET.

22. It is necessary to electrically zero-set the Model 431/432 Power Meter before making a power measurement. To preserve the same zero reference throughout the measurement, maintain the same thermal environment when RF power is applied. Two recommended set-ups for 431 zero-set up are presented in Paragraphs 23 and 25. The recommended set-up for zero-set in the 432 is shown in Paragraph 30.

23. RF POWER TURNED OFF FOR ZERO-SET.

24. There is minimum zero drift when the zero is set with the RF system connected to the thermistor mount and the RF power switch off or greatly attenuated by the generator attenuator. The methods used to switch off RF output in HP signal generators are listed in Table 2. After allowing time for the mount to stabilize thoroughly, follow zero-set procedures in the 431 or 432 Power Meter manual and then turn on the RF source.

Table 2. Methods of Switching Off RF Output of Various HP Signal Generators

HP Generator	Frequency Range	Procedure to Switch Off RF Output
Model 606	50kHz to 65 MHz	Increase the generator output attenuation 30 or more dB
Model 8614A 8616A Model 614 616 Model 618 620	800 to 2400 MHz 1800 to 4500 MHz 800 to 2100 MHz 1800 to 4200 MHz 3.8 to 7.6 GHz 7 to 11 GHz	Release RF pushbutton Set modulation selector to OFF Set modulation selector to OFF
Model 608 Model 682 687	10 to 480 MHz 10 to 420 MHz 1 to 2 GHz 12.4 to 18.0 GHz	Set MOD SELECTOR to PULSE, but do not apply modulation signal to modulation input terminal
Model 612	450 to 1230 MHz	Set MODSELECTOR to PULSE 2, but do not apply modulation signal to modulation input terminal
Model 690, 8690 Series	1 to 20 GHz	Set LINE to STANDBY

25. THERMISTOR MOUNT DISCONNECTED FOR ZERO-SET.

26. 478A 431. When it is inconvenient to turn off the RF power in the RF system, connect the Model 478A mount to the RF system and set RANGE on the Model 431 Power Meter for an approximate midscale reading. When the reading no longer drifts, disconnect the

Note

In the proximity of a high RF field, shield the disconnected thermistor mount from possible stray RF pick-up during the zero-set.

mount from the source, terminate the mount, if necessary, as described in Paragraph 27, and then zero-set the power meter. Immediately reconnect the mount to the RF source for the power measurement.

27. With the Model 478A mount connected to the RF system, the source impedance shunts one of the RF thermistors (see Figure 4); when the Model 478A mount is disconnected, the source impedance is removed. Unless source impedance is high, this variation in impedance affects the RF bridge 10-kHz feedback loop in the power meter, and the zero-level setting obtained with the source disconnected is no longer zero for the measurement. This error can be eliminated by terminating the mount in an impedance which approximately matches the generator impedance at 10 kHz; the termination should be connected while the mount is disconnected (see Paragraph 26) from the source. For example, if the impedance presented by the RF system at 10 kHz is low (1K ohm or less) terminate the thermistor mount in a 50-ohm resistor or a short. On the other hand, if the impedance of the RF system at 10 kHz is high (100 K ohms or more) leave the thermistor mount unterminated during zero-set.

28. Note that some 10-kHz bias signal is coupled into the RF transmission system by C2 (Figure 5). If the RF source output impedance at 10 kHz is 15K ohms or greater, 10-kHz bias voltage is typically 1.3 V RMS and could equal 1.5 V RMS. For an RF source output impedance of 50 ohms at 10 kHz, bias signal voltage is typically 5 mV RMS.

29. The presence of this 10-kHz bias signal may affect solid state RF sources and RF voltmeter measurements. To minimize or eliminate these effects, use an additional blocking capacitor at the Model 478A or a high-pass filter at the RF source output.

30. 478A 432. When it is inconvenient to turn the RF power off while using the 478A 432 combination simply remove the mount from the source, and using the COARSE and FINE ZERO, zero the 432.

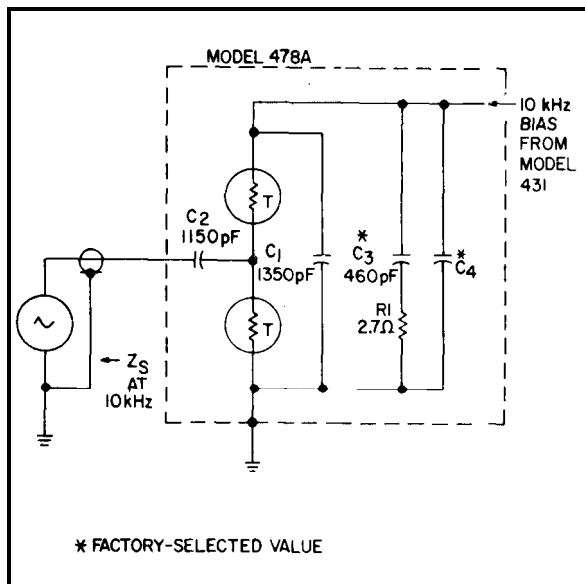

Figure 4. Source Impedance Shunting One RF Thermistor Mount

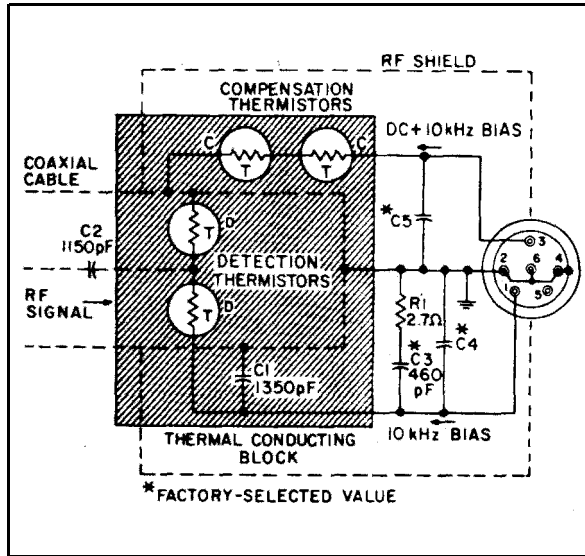

Figure 5. Schematic Diagram of a Model 478A Thermistor Mount when Connected to a 431 Power Meter

31. MOUNT CALIBRATION DATA.

32. The calibration points imprinted on the label of each 478A allow power measurements to be made with increased accuracy. Values of Calibration Factor and Effective Efficiency are given at six frequencies between 10 MHz and 10 GHz. The mounts are tested on a swept-frequency basis to assure accurate interpolation between calibration points. Calibration Factor and Effective Efficiency values are traceable to the National Bureau of Standards to the extent allowed by the Bureau's calibration facilities.

33. CALIBRATION FACTOR. Calibration Factor is the ratio of substituted audio or dc power in a thermistor mount to the microwave RF power incident upon the mount.

$$\text{Calibration Factor} = \frac{P_{dc} \text{ Substituted}}{P_{\text{wave}} \text{ Incident}}$$

34. Calibration Factor is a figure of merit assigned to a thermistor mount to correct for the following sources of error: 1) RF reflected by the mount due to mismatch, 2) RF loss caused by absorption within the mount but not in the detection thermistor elements, and 3) dc-to-microwave power substitution error. Calibration Factor is applied as a correction factor to all measurements made without a tuner. When these factors and thermoelectric effect (refer to Paragraph 39) are taken into consideration, the power indicated is the power that would be delivered by the RF source to the characteristic impedance of the transmission line. The total SWR in the transmission line determines a region of uncertainty about the measured power. This subject is discussed in Application Note 64, available from any Hewlett-Packard Sales and Service Office.

NOTE. Calibration will be performed in the AN/TSM-55V5 Maintenance Calibration Equipment Shelter.

35. EFFECTIVE EFFICIENCY. Effective Efficiency is the ratio of substituted, audio or dc power in a thermistor mount to the microwave RF power dissipated within the mount.

$$\text{Effective Efficiency} = \frac{P_{dc} \text{ Substituted}}{P_{\mu\text{wave}} \text{ Dissipated}}$$

36. Effective Efficiency corrects for power absorbed in parts of the mount other than the detection thermistor elements and dc-to-microwave power substitution error in the thermistor mount. Effective Efficiency is applied as a correction factor when a tuner is used to match the thermistor mount to the transmission line or RF source. In this case, all of the RF power incident upon the mount is absorbed in the mount. Since all power is absorbed in the mount, measurement uncertainty due to mount SWR is eliminated; however, losses in the tuner must be considered.

37. CALIBRATION DATA APPLICATION.

38. When the 478A is used with the Model 431 or 432 Power Meters, Calibration Factor or Effective Efficiency corrections can be made by setting a front panel switch. With the proper setting, the 431 or 432 compensates for the Calibration Factor or Effective Efficiency in the 478A. If the 478A is used with a power meter other than the 431 or 432, Calibration Factor or Effective Efficiency corrections can be made by dividing the measured power by the Calibration Factor or Effective Efficiency value respectively.

39. THERMOELECTRIC EFFECT.

40. Mount calibration uncertainties given in Table 1 include inaccuracies caused by thermoelectric effect error. Calibration Factor uncertainty of $\pm 1.5\%$ and Effective Efficiency uncertainty of $\pm 2.5\%$ can be maintained on the three lowest power ranges of the Model 431 series Power Meters by correcting for the measurement error introduced by thermoelectric effect. An error correction procedure is given in Paragraph 44.

41. A mild thermocouple exists at each point of contact where the connecting wires join to the thermistor elements. Each thermocouple creates a dc voltage. Thus, two thermocouple voltages of opposite relative polarity are formed, one at each junction to each thermistor element.

42. Ideally, each thermocouple voltage would be equal in magnitude so that they cancel with no resultant effect on the accuracy of power measurement. In practice however, each point of contact does not have identical thermocouple characteristics, and in addition, the temperatures at each junction may not be the same. These differences cause an incomplete cancellation of the thermoelectric voltages, resulting in a voltage that causes a thermoelectric effect error. The magnitude of the error is important when making dc substitution measurements on the 0.1 mW, 0.03 mW and 0.01 mW ranges with one of the Model 431 series Power Meters. On other ranges, the effect is negligible. Maximum error introduced by thermoelectric effect is about 0.3 μW and is typically 0.1 μW on the 0.01 mW range.

43. THERMOELECTRIC EFFECT ERROR CORRECTION FOR 478A 431 COMBINATION.

44. Use the following technique to correct for thermoelectric effect error.

- a. Measure power.
- b. Connect a HP Model 8402 Power Meter Calibrator to the power meter DC CALIBRATION AND SUBSTITUTION connector.
- c. Zero and null power meter.
- d. By dc substitution (refer to procedure in 431 Manual), duplicate power measurement made in step a. Calculate and record substituted power as P_1 .
- e. Reverse connection polarity between the calibrator and power meter.
- f. Re-zero and re-null power meter, if necessary.
- g. By dc substitution, duplicate lower measurement made in step a. Calculate and record substituted power as P_2 .
- h. Calculate arithmetic mean of the two substitution powers P_1 and P_2 . This mean power includes a correction for thermoelectric effect error.

$$\text{Power} = \frac{P_1 + P_2}{2}$$

45. THERMOELECTRIC ERROR FOR 478A 432 COMBINATION.

46. The thermoelectric errors present in the 431 are minimized in the 432 since the thermoelectric voltage is negligible compared with the dc voltage used to bias the thermistor bridges.

OPERATING PRINCIPLES

47. CIRCUIT DESCRIPTION.

48. Two matched series thermistors are mounted on a common thermal conducting block, represented by the shaded rectangle in Figure 5. One pair, marked "D" for detection, is mounted between the end of a coaxial cable and cylindrical cavity. These thermistors are exposed to incoming RF power which heats them, lowering their resistance. The other pair, marked "C" for compensation and situated immediately outside the cavity, is completely shielded from RF. With the 478A attached to the 431 Power Meter, the detection thermistors are part of the metering circuit.

49. With the 478A attached to the 432 Power Meter the detection thermistors are part of the RF bridge and the compensation thermistors are part of the compensation bridge. Since the two pairs of thermistors show the same thermal environment, any change in temperature which affects the RF bridge simultaneously affects the metering bridge; this allows the power meter circuit to compensate for changes in temperature and thus minimize drift.

50. During 431 478A operation, sufficient amounts of dc and 10 kHz bias currents are supplied from the 431 Power Meter to heat the thermistors until their resistances are reduced to approximately 200 Ω per series pair. Capacitor C1 offers high impedance to 10 kHz, but is practically a short to RF. This causes "D" to appear series connected to 10 kHz, but parallel connected to RF. In this manner, "D" appears to the audio bridge of the 431 Power Meter as a 200 Ω resistance, but terminates the coaxial cable in 50 Ω . Capacitor C2 blocks any dc and audio power that may be present in the incoming signal, and passes only RF power.

51. During 432 operation (see Figure 6) sufficient amounts of dc current are supplied from 432 Power Meter to heat the thermistors until their resistances are reduced to approximately 200 Ω per series pair. Capacitor C1 is practically a short to RF. This causes "D" to appear series connected to the dc bridge, parallel connected to RF. In this manner, "D" appears to the dc bridge in the 432 Power Meter as a 200 Ω resistance that terminates the coaxial cable into 50 Ω . Capacitor C2 blocks any dc and audio power that may be present in the incoming signal and passes only RF power.

52. 431 POWER METER DETECTION.

53. Under normal operation, the total power supplied to heat thermistor pair "D" (see Figure 5) consists of 1) RF signal, 2) 10 kHz bias, 3) heat from the environment. The total power supplied to heat thermistor pair "C" consists of: 1) dc bias, 2) an equal amount of 10 kHz bias, and 3) heat from the same environment. As "D" and "C" are matched thermally, the total amounts of heat applied to reduce their series resistance equally must be equal.

54. 432 POWER DETECTION.

55. Under normal operation the total power applied to heat thermistor pair "D" (see Figure 6) consists of: 1) RF signal and 2) heat from the environment. The total power supplied to heat thermistor "C" consists of: 1) dc bias and 2) heat from the same environment. As "D" and "C" are matched thermally, the total amounts of heat applied to reduce their series resistance equally must be equal.

MAINTENANCE

56. MECHANICAL SHOCK.

57. The Model 478A is a precision instrument. Avoid dropping or other mechanical shocks. Such shocks can destroy the match between the thermistors.

58. CHECK ON THERMISTOR MATCH.

59. Match between the thermistors may be checked by comparing the thermistor resistances under simulated operating conditions. Equipment required is indicated in Figure 6. Make connections to the connector at the rear of the thermistor mount; pins are shown in Figure 6. Note that the small battery in series with the HP Model 3440 Digital Voltmeter is connected in opposition

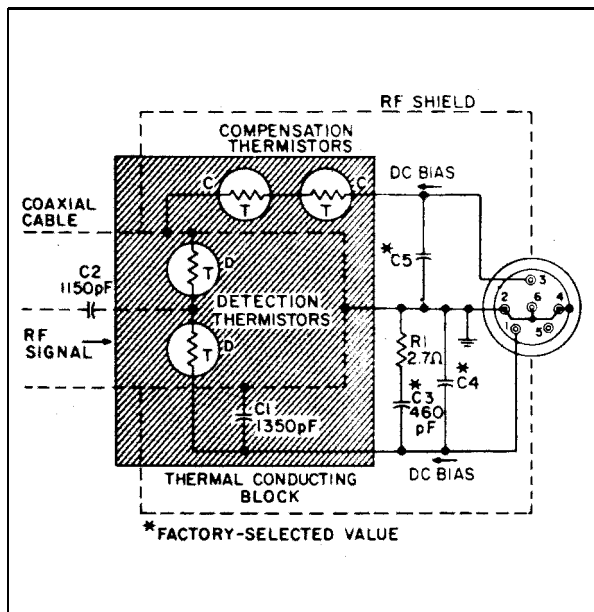

Figure 6. Schematic Diagram of a Model 478A Thermistor Mount when Connected to a 432 Power Meter

WARNING

Under no conditions should the mount be required to carry a current higher than 14 mA.

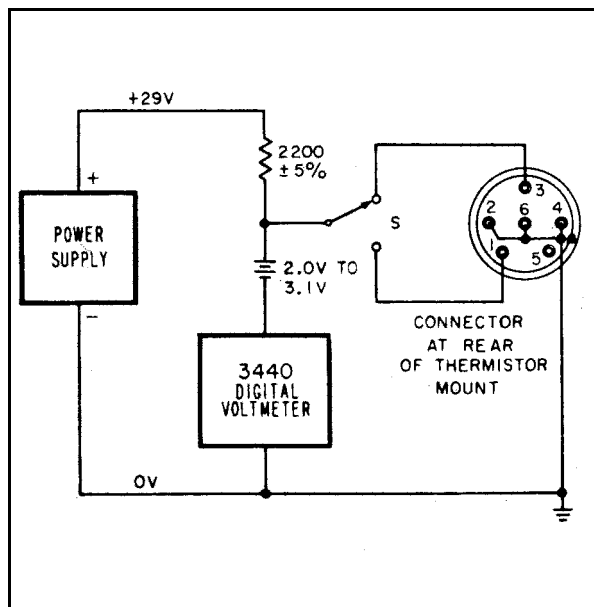

Figure 7. Check on Model 478A Thermistor Resistance Match

to the power supply. The value of this bucking voltage should be such that voltmeter resolution down to 0.001 volt is obtained. Take readings with switch S connected to pin 1 and then to pin 3. Thermistor match is satisfactory if the two readings do not differ by more than 0.030 volt. Nonoperating mounts with readings as high as 0.150 volt can probably be repaired as outlined in the succeeding paragraphs.

60. REPAIR.

61. Exceeding the cw or pulse power limit of the Model 478A Thermistor Mount may result in damage such that the mount will no longer zero on the Model 431 or 432 Power Meter.

62. Before adjusting the mount in any way, make sure that the mount is the cause of the problem. An open or short indication, using the checks in Paragraphs 59 or 64, means that the mount is not repairable by the procedures outlined in the following paragraphs. However, the mount may be nonoperative but still repairable. Test for this by using the procedures in Paragraph 58, or by connecting the mount to a Model 431 or 432 Power Meter and a cable which is known to be good. A faulty cable will not have continuity through the respective connector pins or may have poor contact in the mount connector. Poor contact will show as an intermittancy or a great deal of noise (visible on the 431 or 432 Meter) when the cable is gently flexed near the connector end.

Note

The following procedures are set down for the 431 478A combination. The same procedures can be used for the 432 except for the ZERO VERNIER control. These controls on the 431 are replaced by the COARSE ZERO and FINE ZERO control on the 432.

63. The major difference between the 478A 431 and 478A 432 combination is that the 478A 432 combination does not use 10 kHz as a biasing factor in the thermistor. All biasing factors in the 432 are from dc sources therefore, lowering the thermoelectric effect.

64. To troubleshoot a damaged mount, proceed as follows:

- a. Connect mount to Model 431.
- b. Set:

MOUNT RES	200 ohm
RANGE	10 mW
POWER	ON
- c. Rotate ZERO from one limit to the other.

65. If meter remains pegged upscale, the thermistor elements have been damaged. However, it may be possible to recompensate the thermistors per Paragraphs 68 and 69 and return the mount to operation; otherwise they must be replaced. In either case, the Effective Efficiency and Calibration Factor data on the nameplate are no longer valid (see Paragraph 77).

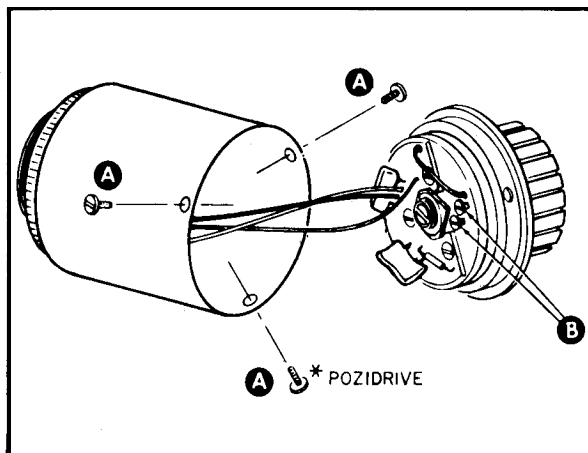

Figure 8. Thermistor Compensation

66. If meter remains pegged downscale, measure resistance between pins 1 and 2, and pins 3 and 4. The resistance should measure between 1000 and 5000 ohms. An open or shorted reading indicates the need for replacement of the thermistors.

67. If the resistance reading is satisfactory, it may be possible to recompensate the mount and return it to service. The drift with temperature changes will be higher because of the damage to the thermistors, but it will be possible to zero the meter and to make measurements. The Effective Efficiency and Calibration Factor indicated on the label will no longer be valid (see Paragraph 77). There are two adjusting screws inside the instrument which permit recompensation within limits. Most instruments with serials lower than 7663 do not have the adjusting screws at the time of manufacture, but are modified if the instrument was sent in for repair after March 1964.

68. Refer to Figure 8 and proceed as follows:

- a. Remove the three screws (A).
- b. Slide instrument out of its cover.
- c. Plug cover into Model 431.
- d. Set: MOUNT RES 200 ohm
POWER ON

69. If meter is pegged downscale:

- a. Set RANGE to 10 mW.
- b. Set ZERO and VERNIER to mid-range.
- c. Turn screws (B) clockwise, 1 8 turn alternately.

CAUTION

If there is a sudden jump in meter indication when advancing either screw, back off 1 8 turn, and do not advance that screw further. Check resistance as in Paragraph 66. If either screw bottoms, do not apply force. Thermistor replacement (Paragraph 71) is indicated.

d. When meter pointer rises, trim to zero with each adjusting screw.

e. Replace cover and three screws (A). The instrument is now operative.

Note

Make sure the three screws in the body of the thermistor mount are tight when the mount is put together; this insures quiet operation.

70. If meter is pegged upscale:

- a. Set ZERO and VERNIER to mid-range.
- b. Set RANGE to highest position which will not peg the meter.
- c. Turn one of the screws (B) counterclockwise to obtain a meter reading half that observed in step b.
- d. Turn the other screw (B) counterclockwise to zero the meter. If it is impossible to zero the meter, replace the thermistors (Paragraph 71).
- e. Replace cover and three screws (A). The instrument is now operative.

71. THERMISTOR ASSEMBLY REPLACEMENT PROCEDURE.

Note

After replacement of the thermistor assembly, the Effective Efficiency and Calibration Factor indicated on the label of the mount are no longer valid (see Paragraph 77).

72. The procedure consists of removing the damaged thermistor assembly, the printed circuit assembly and replacing them with pretested assemblies included in

Table 3. Parts Furnished in Thermistor Assembly Replacement Kit, HP 00478-600

Qty	Description	HP Stock No.
1	Thermistor Assembly	478A-95A
1	Etched Circuit Board	478A-65A
1	Resistor, fixed composition, 2.7 ohms ±10% 1 4W	0684-0271
1 or 2	Capacitors, fixed, dipped mica	
* Factory Selected.		

Model. 478A

Thermistor Assembly Replacement Kit. HP Stock No. 00478-600.

73. The replacement assemblies are pretested at the factory. However, since the operation of the thermistor mount depends on proper installation of the assembly, it may be desirable to check the SWR and efficiency following replacement. The efficiency may be checked by comparing against a known mount. The SWR is checked at 9 GHz and 10 GHz. SWR should be approximately equal at 9 and 10 GHz, and should be 1.5 or less.

Note

In the field, replaceable thermistor assembly connection of the RF thermistors to the Type N center conductor is made by a bellows. If the bellows does not contact the center conductor, SWR will be about 2.0 at 10 GHz. The bellows may be lengthened slightly with a pair of tweezers.

74. The following special tools may be required for the completion of this procedure:

- a. One small screwdriver, 0.070 tip, suitable for removing a 00-90 x 1.8 screw.
- b. One pair of tweezers.

75. REMOVAL PROCEDURE.

a. Remove three 2-56 x 3/16 screws holding terminal shield (Figure 9). Move terminal shield aside.

CAUTION

Do not break wires connecting printed circuit assembly to receptacle connector.

b. Loosen locknut and remove 5 16-32 setscrew from thermistor assembly.

c. Disconnect the three wires between the printed circuit assembly and the receptacle connector from the printed circuit assembly.

d. In early thermistor assemblies there is a 00-90 x 1.8 screw used to connect the RF Thermistors to the Type N center conductor. Remove this screw, if present, using small screwdriver and tweezers.

e. Remove the three 2-56 x 5/8 inch screws holding printed circuit and thermistor assemblies to the RF connector assembly.

f. Remove printed circuit and thermistor assemblies.

g. Remove the three insulator bushings from thermistor assembly. This completes the removal of the damaged assembly.

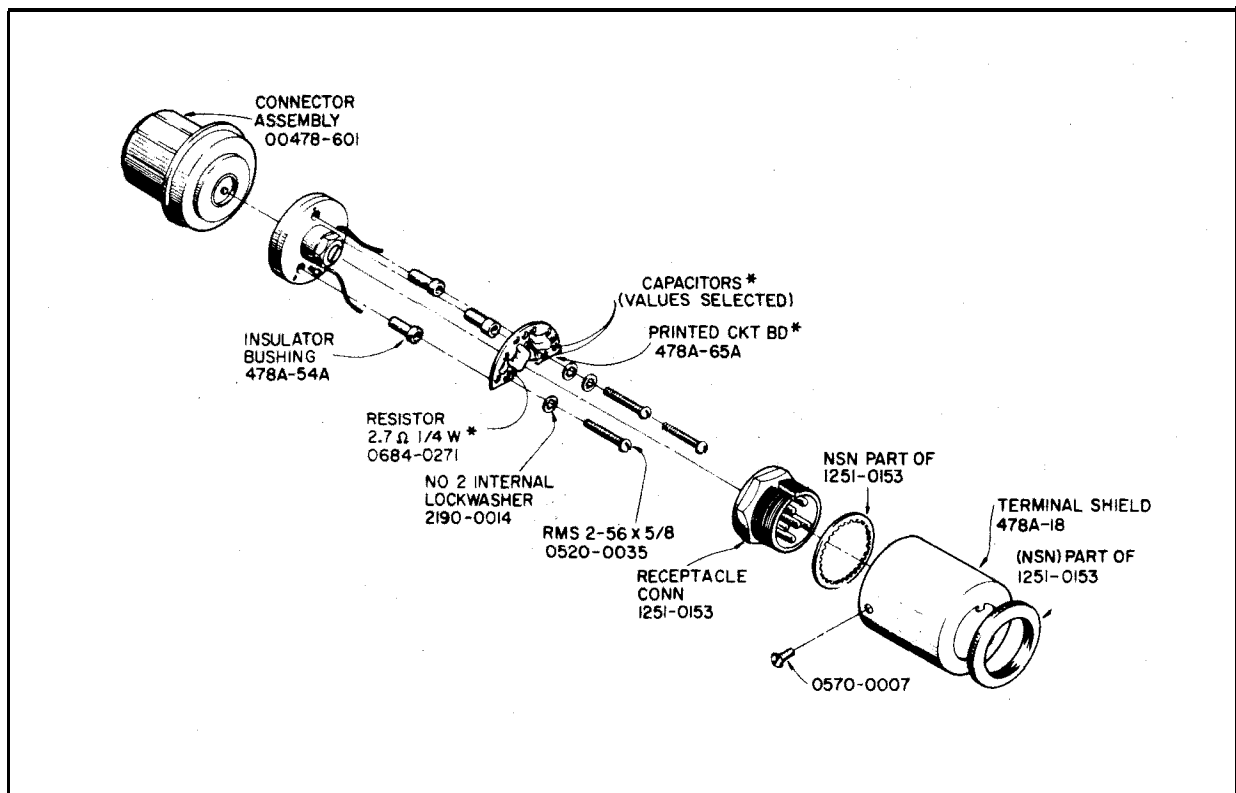

Figure 9. Model 478A Thermistor Mount Assembly

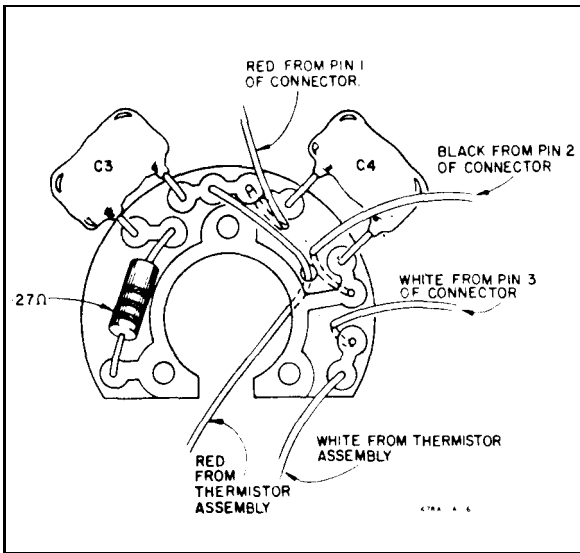

Figure 10. HP Model 478A Printed Circuit Assy Wiring

76. INSTALLATION PROCEDURE.

a. Referring to Figure 10, connect the three wires from receptacle connector to printed circuit assembly.

Note

For strain relief, the wires should go through the holes indicated and connect from the bottom of the printed circuit assembly.

b. Install the three insulator bushings in the thermistor assembly.

c. Pass the red wire from the thermistor assembly through the hole indicated in Figure 10. Do not connect to printed circuit assembly at this time.

d. Mount thermistor and printed circuit assemblies on RF connector assembly. Use three 2-56 x 5/8 inch screws and lockwashers. Screws must be tightened firmly to insure proper bellows contact with the Type N center conductor.

Note

Printed circuit assembly must be positioned so it does not cover compensating screws.

e. Connect red and white wires from thermistor assembly to printed circuit assembly.

f. Connect thermistor mount to a HP Model 431. Check for proper null and zero.

g. If desired, check SWR and efficiency. The Mount SWR has been adjusted at the factory to be about equal at 9 GHz and 10 GHz and less than 1.5. The adjustment is made with the 5/16-23 setscrew which is secured by a locknut. The setscrew should not be moved unless SWR is being recalibrated. Efficiency may be checked by comparing to a known good mount.

CAUTION

To prevent pulling wires out of terminal connector, secure terminal shield with one 2-56 x 3/16 inch screw while making checks.

h. When any testing or recalibration is completed, secure terminal shield with three 2-56 x 3/16 inch screws. This completes the Installation Procedure.

77. RECALIBRATION. If recalibration of the mount is desired, the instrument may be sent to the factory for repair and recalibration. Any Hewlett - Packard Sales and Service Office will arrange for such repair.

MANUAL CHANGES

BACKDATING

MODEL 432A
POWER METER

Manual Serial Prefixed: 812- Manual Printed: August 1968

MAKE ALL CO IN THIS MANUAL ACCORDING TO ERRATA BELOW. THEN CHECK THE FOLLOWING TABLE FOR YOUR INSTRUMENT SERIAL PREFIX (3 DIG OR SERIAL NUMBER (8 DIG AND MAKE ANY LISTED CHANGE(S) IN THE MANUAL.

. NEW ITEM.

SERIAL PREFIX OR NUMBER	MAKE MANUAL CHANGES	SERIAL PREFIX OR NUMBER	MAKE MANUAL CHANGES
812-00201 & above	Change 1, 4		
840	Change 1, 2, 4		
843	Change 1, 2, 3, 4		

- CHANGE 1** Change A2R61 and A2R62 to R: FXD 215K OHM 0698-3454
 Change A2R36 to R: FXD 1M OHM 0683-1055
 Change A2C24 to C: FXD 270 PF 0140-0210
 Add A2C48 from A3Q38 base to ground. C: FXD 68 PF 0490-0192
- CHANGE 2** Add A1R3 between A1 pin 11 and +7 Vdc. R: FXD 3 1.6K 0698-3160
 Delete A1R43.
- CHANGE 3** Add A2C49 between A2 pin 15 and junction of A2R59 and A2R57.
 C: FXD 2.2 μ f 0180-0197
 Add A2R29 between  and the bottom of A2C31.
 R: FXD 68.1 Ω 0757-0397
- CHANGE 4** Figure A1-1, A1-2, A1-3 and Table A1-1 and A1-2 apply to 432A Power Meters with serial prefix 843 and below.

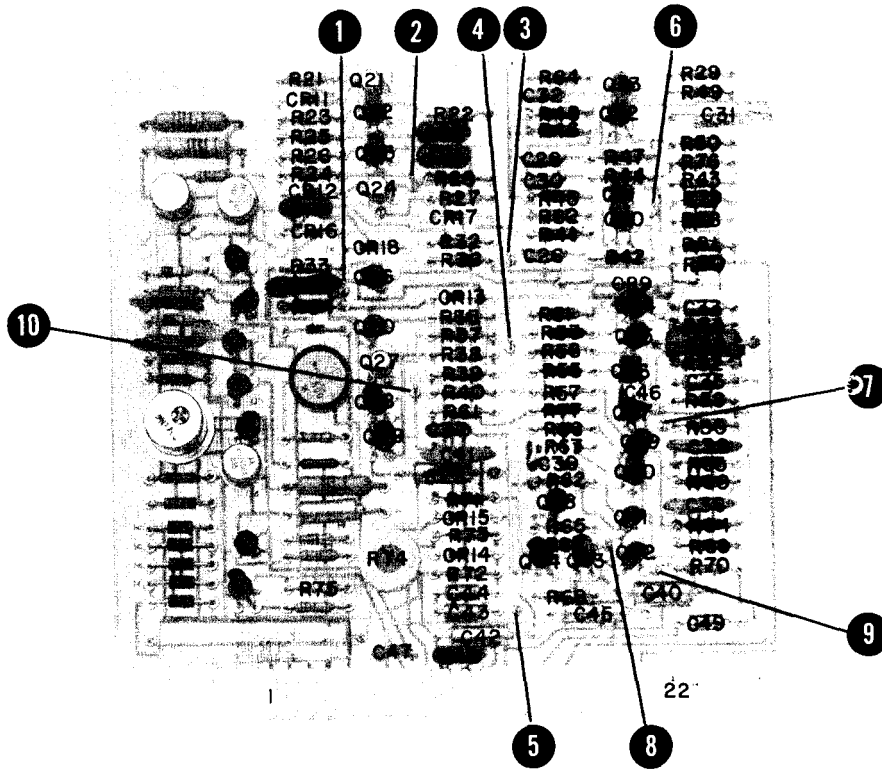

Figure A1-1. A2 Meter Logic Component Locations

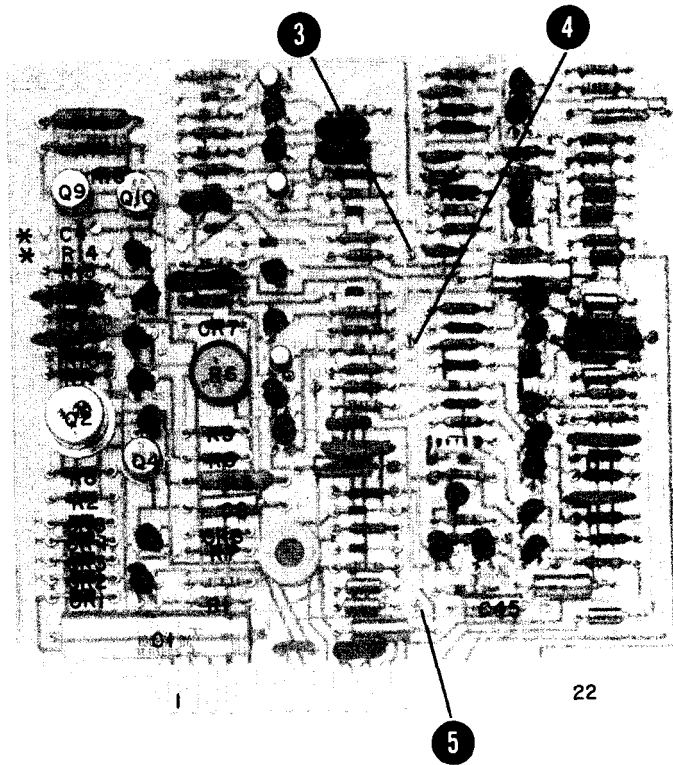

Figure A1-2. A2 Meter Logic Assembly, Power Supply Component Locations

Table A1-1. Reference Designation Index

Reference Designation	Part No.	Description #	Note
A2	00432-6002	BOARD ASSY: LOGIC	
	00432-2002	BOARD: BLANK PC	
A2C1	0180-1819	C:FXD ELECT 100 UF +75-10% 50VDCW	
A2C2	0180-0229	C:FXD ELECT 33 UF 10% 10VDCW	
A2C3	0160-2917	C:FXD CER 0.05 UF +80-20% 100VDCW	
A2C4	0160-2917	C:FXD CER 0.05 UF +80-20% 100VDCW FACTORY SELECTED PART	
A2C5	0160-2917	C:FXD CER 0.05 UF +80-20% 100VDCW	
A2C6-		NOT ASSIGNED	
A2C20		NOT ASSIGNED	
A2C21	0140-0234	C:FXD MICA 500 PF 1%	
A2C22	0140-0234	C:FXD MICA 500 PF 1%	
A2C23	0180-1746	C:FXD ELECT 15 UF 10% 20VDCW	
A2C24	0140-0198	C:FXD MICA 200 PF 5%	
A2C25	0160-0978	C:FXD MICA 1500 PF 1% 500VDCW	
A2C26	0160-2930	C:FXD CER 0.01 UF +80-20% 100VDCW	
A2C27		NOT ASSIGNED	
A2C28	0160-2930	C:FXD CER 0.01 UF +80-20% 100VDCW	
A2C29	0180-2178	C:FXD ELECT 220 UF 20% 8VDCW	
A2C30	0160-2930	C:FXD CER 0.01 UF +80-20% 100VDCW	
A2C31	0180-1940	C:FXD ELECT 33 UF 10% 15VDCW	
A2C32	0160-2930	C:FXD CER 0.01 UF +80-20% 100VDCW	
A2C33	0180-0197	C:FXD ELECT 2.2 UF 10% 20VDCW	
A2C34	0160-2672	C:FXD MY 0.047 UF 5% 80VDCW	
A2C35	0180-0197	C:FXD ELECT 2.2 UF 10% 20VDCW	
A2C36	0160-2917	C:FXD CER 0.05 UF +80-20% 100VDCW	
A2C37	0160-2143	C:FXD CER 2000 PF +80-20% 1000VDCW	
A2C38	0160-2917	C:FXD CER 0.05 UF +80-20% 100VDCW	
A2C39	0160-2265	C:FXD CER 22 PF 5% 500VDCW	
A2C40	0180-0229	C:FXD ELECT 33 UF 10% 10VDCW	
A2C41	0160-2917	C:FXD CER 0.05 UF +80-20% 100VDCW	
A2C42	0180-0106	C:FXD ELECT 60 UF 20% 6VDCW	
A2C43	0180-0197	C:FXD ELECT 2.2 UF 10% 20VDCW	
A2C44	0180-0291	C:FXD ELECT 1.0 UF 10% 35VDCW	
A2C45	0180-0106	C:FXD ELECT 60 UF 20% 6VDCW	
A2C46	0150-0059	C:FXD CER 3.3-0.25 PF 500VDCW	
A2C47	0160-2930	C:FXD CER 0.01 UF +80-20% 100VDCW	
A2C48		NOT ASSIGNED	
A2C49	0180-0197	C:FXD ELECT 2.2 UF 10% 20VDCW	
A2CR1	1901-0026	DIODE:SILICON 0.75A 200 PIV	
A2CR2	1901-0026	DIODE:SILICON 0.75A 200 PIV	
A2CR3	1901-0026	DIODE:SILICON 0.75A 200 PIV	
A2CR4	1901-0026	DIODE:SILICON 0.75A 200 PIV	
A2CR5		NOT ASSIGNED	

See introduction to section VI for ordering information

Table A1-1. Reference Designation Index (Cont'd)

Reference Designation	Part No.	Description #	Note
A2CR6	1902-0033	DIODE BREAKDOWN:6.2V	
A2CR7	1901-0040	DIODE:SILICON 30MA 30WV	
A2CR8	1901-0026	DIODE:SILICON 0.75A 200 PIV	
A2CR9		NOT ASSIGNED	
A2CR10		NOT ASSIGNED	
A2CR11	1901-0040	DIODE:SILICON 30MA 30WV	
A2CR12	1901-0040	DIODE:SILICON 30MA 30WV	
A2CR13	1901-0040	DIODE:SILICON 30MA 30WV	
A2CR14	1901-0040	DIODE:SILICON 30MA 30WV	
A2CR15	1901-0040	DIODE:SILICON 30MA 30WV	
A2CR16	1901-0040	DIODE:SILICON 30MA 30WV	
A2CR17	1901-0040	DIODE:SILICON 30MA 30WV	
A2CR18	1901-0040	DIODE:SILICON 30MA 30WV	
A2Q1	1854-0071	TRANSISTOR: SILICON NPN	
A2Q2	1854-0062	TRANSISTOR:SILICON NPN 2N1701	
A2Q3	1854-0071	TRANSISTOR:SILICON NPN	
A2Q4	1853-0012	TRANSISTOR:PNP SILICON 2N2904A	
A2Q5	1853-0020	TRANSISTOR: SILICON PNP	
A2Q6	1853-0020	TRANSISTOR:SILICON PNP	
A2Q7	1853-0020	TRANSISTOR:SILICON PNP	
A2Q8	1854-0071	TRANSISTOR:SILICON NPN	
A2Q9	1854-0003	TRANSISTOR:NPN SILICON	
A2Q10	1853-0001	TRANSISTOR:PNP SILICON 30V 900MW	
A2Q11	1854-0071	TRANSISTOR:SILICON NPN	
A2Q12-		NOT ASSIGNED	
A2Q19		NOT ASSIGNED	
A2Q20	1853-0020	TRANSISTOR: SILICON PNP	
A2Q21	1854-0005	TRANSISTOR:SILICON NPN 2N708	
A2Q22	1854-0071	TRANSISTOR:SILICON NPN	
A2Q23	1854-0071	TRANSISTOR: SILICON NPN	
A2Q24	1854-0005	TRANSISTOR: SILICON NPN 2N708	
A2Q25		NOT ASSIGNED	
A2Q26	1854-0071	TRANSISTOR:SILICON NPN	
A2Q27	1854-0005	TRANSISTOR:SILICON NPN 2N708	
A2Q28	1854-0071	TRANSISTOR:SILICON NPN	
A2Q29	1854-0071	TRANSISTOR: SILICON NPN	
A2Q30	1854-0071	TRANSISTOR:SILICON NPN	
A2Q31	1853-0020	TRANSISTOR:SILICON PNP	
A2Q32	1854-0071	TRANSISTOR:SILICON NPN	
A2Q33	1853-0020	TRANSISTOR: SILICON PNP	
A2Q34	1854-0071	TRANSISTOR:SILICON NPN	
A2Q35	1854-0071	TRANSISTOR:SILICON NPN	
A2Q36	1853-0015	TRANSISTOR:SILICON PNP 2N3640	
A2Q37	1853-0020	TRANSISTOR:SILICON PNP	
A2Q38	1854-0071	TRANSISTOR:SILICON NPN	
A2Q39	1854-0071	TRANSISTOR:SILICON NPN	
A2Q40	1854-0071	TRANSISTOR:SILICON NPN	

See introduction to section VI for ordering information

Table A1-1. Reference Designation Index (Cont'd)

Reference Designation	Part No.	Description #	Note
A2Q41	1853-0020	TRANSISTOR: SILICON PNP	
A2Q42	1853-0020	TRANSISTOR: SILICON PNP	
A2Q43	1854-0071	TRANSISTOR: SILICON NPN	
A2Q44	1854-0071	TRANSISTOR: SILICON NPN	
A2R1	0757-0279	R:FXD MET FLM 3.16K OHM 1% 1/8W	
A2R2	0683-0685	R:FXD COMP 6.8 OHM 5% 1/4W	
A2R3	0757-0835	R:FXD MET FLM 6.81K OHM 1% 1/2W	
A2R4		NUT ASSIGNED	
A2R5	0698-3156	R:FXD MET FLM 14.7K OHM 1% 1/8W	
A2R6	2100-1773	R:VAR WW 1K OHM 10% LIN 1/2W	
A2R7	0757-0289	R:FXD MET FLM 13.3K OHM 1% 1/8W	
A2R8	0757-0280	R:FXD MET FLM 1K OHM 1% 1/8W	
A2R9	0698-3160	R:FXD MET FLM 31.6K OHM 1% 1/8W	
A2R10	0698-3441	R:FXD MET FLM 215 OHM 1% 1/8W FACTORY SELECTED PART	
A2R11	0757-0465	R:FXD MET FLM 100K OHM 1% 1/8W	
A2R12	0757-0442	R:FXD MET FLM 10.0K OHM 1% 1/8W	
A2R13	0698-3136	R:FXD MET FLM 17.8K OHM 1% 1/8W	
A2R14	0757-0346	R:FXD MET FLM 10 OHM 1% 1/8W FACTORY SELECTED PART	
A2R15	0757-0442	R:FXD MET FLM 10.0K OHM 1% 1/8W	
A2R16	0757-0279	R:FXD MET FLM 3.16K OHM 1% 1/8W	
A2R17	0757-0198	R:FXD MET FLM 100 OHM 1% 1/2W	
A2R18	0698-3401	R:FXD MET FLM 215 OHM 1% 1/2W	
A2R19		NUT ASSIGNED	
A2R20		NUT ASSIGNED	
A2R21	0698-3156	R:FXD MET FLM 14.7K OHM 1% 1/8W	
A2R22	0757-0442	R:FXD MET FLM 10.0K OHM 1% 1/8W	
A2R23	0757-0442	R:FXD MET FLM 10.0K OHM 1% 1/8W	
A2R24	0698-3260	R:FXD MET FLM 464K OHM 1% 1/8W	
A2R25	0698-3260	R:FXD MET FLM 464K OHM 1% 1/8W	
A2R26	0757-0442	R:FXD MET FLM 10.0K OHM 1% 1/8W	
A2R27	0757-0442	R:FXD MET FLM 10.0K OHM 1% 1/8W	
A2R28	0698-3156	R:FXD MET FLM 14.7K OHM 1% 1/8W	
A2R29-		NUT ASSIGNED	
A2R31		NUT ASSIGNED	
A2R32	0757-0199	R:FXD MET FLM 21.5K OHM 1% 1/8W	
A2R33	0757-0442	R:FXD MET FLM 10.0K OHM 1% 1/8W	
A2R34	0757-0465	R:FXD MET FLM 100K OHM 1% 1/8W	
A2R35	0698-3454	R:FXD MET FLM 215K OHM 1% 1/8W	
A2R36	0757-0461	R:FXD MET FLM 68.1K OHM 1% 1/8W	
A2R37	0757-0470	R:FXD MET FLM 162K OHM 1% 1/8W	
A2R38	0757-0442	R:FXD MET FLM 10.0K OHM 1% 1/8W	
A2R39	0698-3155	R:FXD MET FLM 4.64K OHM 1% 1/8W	
A2R40	0698-3155	R:FXD MET FLM 4.64K OHM 1% 1/8W	
A2R41	0757-0465	R:FXD MET FLM 100K OHM 1% 1/8W	
A2R42	0757-0461	R:FXD MET FLM 68.1K OHM 1% 1/8W	
A2R43	0757-1094	R:FXD MET FLM 1.47K OHM 1% 1/8W	
A2R44	0757-0461	R:FXD MET FLM 68.1K OHM 1% 1/8W	
A2R45	0757-0465	R:FXD MET FLM 100K OHM 1% 1/8W	

See introduction to section VI for ordering information

Appendix 1

Table A1-1. Reference Designation Index (Cont'd)

Reference Designation	Part No.	Description #	Note
A2R46	0757-0465	R:FXD MET FLM 100K OHM 1% 1/8W	
A2R47	0757-0461	R:FXD MET FLM 68.1K OHM 1% 1/8W	
A2R48	0757-0465	R:FXD MET FLM 100K OHM 1% 1/8W	
A2R49	0757-0461	R:FXD MET FLM 68.1K OHM 1% 1/8W	
A2R50	0757-0280	R:FXD MET FLM 1K OHM 1% 1/8W	
A2R51	0698-3260	R:FXD MET FLM 464K OHM 1% 1/8W	
A2R52	0757-0279	R:FXD MET FLM 3.16K OHM 1% 1/8W	
A2R53	0698-3160	R:FXD MET FLM 31.6K OHM 1% 1/8W	
A2R54	0698-3428	R:FXD MET FLM 14.7 OHM 1% /8W FACTORY SELECTED PART	
A2R55	0698-3160	R:FXD MET FLM 31.6K OHM 1% 1/8W FACTORY SELECTED PART	
A2R56	0698-3260	R:FXD MET FLM 464K OHM 1% /8W	
A2R57	0757-0442	R:FXD MET FLM 10.0K OHM 1% 1/8W	
A2R58	0698-3260	R:FXD MET FLM 464K OHM 1% /8W	
A2R59	0698-3260	R:FXD MET FLM 464K OHM 1% 1/8W	
A2R60	0698-0084	R:FXD MET FLM 2.15K OHM 1% 1/8W	
A2R61	0698-3260	R:FXD MET FLM 464K OHM 1% 1/8W	
A2R62	0698-3260	R:FXD MET FLM 464K OHM 1% 1/8W	
A2R63	0698-3260	R:FXD MET FLM 464K OHM 1% 1/8W	
A2R64	0757-0439	R:FXD MET FLM 6.81K OHM 1% 1/8W	
A2R65	0757-0442	R:FXD MET FLM 10.0K OHM 1% 1/8W	
A2R66	0757-0461	R:FXD MET FLM 68.1K OHM 1% 1/8W	
A2R67	0698-3160	R:FXD MET FLM 31.6K OHM 1% 1/8W	
A2R68	0757-0442	R:FXD MET FLM 10.0K OHM 1% 1/8W	
A2R69	0698-3438	R:FXD MET FLM 147 OHM 1% 1/8W	
A2R70	0698-3156	R:FXD MET FLM 14.7K OHM 1% 1/8W	
A2R71	0698-3160	R:FXD MET FLM 31.6K OHM 1% 1/8W	
A2R72	0698-3444	R:FXD MET FLM 316 OHM 1% 1/8W	
A2R73	0757-0199	R:FXD MET FLM 21.5K OHM 1% 1/8W	
A2R74	2100-1769	R:VAR WW 50 OHM 10% LIN 1/2W	
A2R75	0698-4466	R:FXD MET FLM 976 OHM 1% 1/8W	
A2R76	0757-0346	R:FXD MET FLM 10 OHM 1% 1/8W	
A2R77	0698-3160	R:FXD MET FLM 31.6K OHM 1% 1/8W	
A2R78	0811-2277	R:FXD WW 10K OHM 0.1% 1/40W	
A2R79	0811-2277	R:FXD WW 10K OHM 0.1% 1/40W	
A2R80	0811-2537	R:FXD WW 5K OHM 0.1% 1/4W	
A2R81	0757-0465	R:FXD MET FLM 100K OHM 1% 1/8W FACTORY SELECTED PART	
A2R82	0757-0401	R:FXD MET FLM 100 OHM 1% 1/8W	
A2R83	0698-3441	R:FXD MET FLM 215 OHM 1% 1/8W	
A2R84	0757-0280	R:FXD MET FLM 1K OHM 1% 1/8W	
A2	0360-0124	TERMINAL:SOLDER LUG	

See introduction to section VI for ordering information

Table A1-2. Replaceable Parts

Part No.	Description #	Mfr.	Mfr. Part No.	TQ
0140-0198	C:FXD MICA 200 PF 5%	28480	0140-0198	1
0140-0234	C:FXD MILA 500 PF 1%	28480	0140-0234	2
0150-0059	C:FXD CER 3.3-0.25 PF 500VDCW	72982	301-000-COJO-339C	1
0160-0978	C:FXD MICA 1500 PF 1% 500VDCW	28480	0160-0978	1
0160-2143	C:FXD CER 2000 PF +80-20% 1000VDCW	91418	TYPE B	1
0160-2265	C:FXD CER 22 PF 5% 500VDCW	72982	301-NPO-22PF	1
0160-2672	C:FXD MY 0.047 UF 5% 80VDCW	28480	0160-2672	1
0160-2917	C:FXD CER 0.05 UF +80-20% 100VDCW	84411	TYPE TA	6
0160-2930	C:FXD CER 0.01 UF +80-20% 100VDCW	91418	TA	5
0180-0106	C:FXD ELECT 60 UF 20% 6VDCW	28480	0180-0106	2
0180-0197	C:FXD ELECT 2.2 UF 10% 20VDCW	28480	0180-0197	4
0180-0229	C:FXD ELECT 33 UF 10% 10VDCW	28480	0180-0229	2
0180-0291	C:FXD ELECT 1.0 UF 10% 35VDCW	28480	0180-0291	1
0180-1746	C:FXD ELECT 15 UF 10% 20VDCW	28480	0180-1746	1
0180-1819	C:FXD ELECT 100 UF +75-10% 50VDCW	28480	0180-1819	1
0180-1940	C:FXD ELECT 33 UF 10% 15VDCW	56289	109D336X9015C2-DYP	1
0180-2178	C:FXD ELECT 220 UF 20% 8VDCW	56289	109D227X0008F2-DYP	1
0360-0124	TERMINAL:SOLDER LUG	28480	0360-0124	10
0683-0685	R:FXD COMP 6.8 OHM 5% 1/4W	01121	CB68G5	1
0698-0084	R:FXD MET FLM 2.15K OHM 1% 1/8W	28480	0698-0084	1
0698-3136	R:FXD MET FLM 17.8K OHM 1% 1/8W	28480	0698-3136	1
0698-3155	R:FXD MET FLM 4.64K OHM 1% 1/8W	28480	0698-3155	2
0698-3156	R:FXD MET FLM 14.7K OHM 1% 1/8W	28480	0698-3156	4
0698-3160	R:FXD MET FLM 31.6K OHM 1% 1/8W	28480	0698-3160	6
0698-3260	R:FXD MET FLM 464K OHM 1% 1/8W	28480	0698-3260	9
0698-3401	R:FXD MET FLM 215 OHM 1% 1/2W	28480	0698-3401	1
0698-3428	R:FXD MET FLM 14.7 OHM 1% 1/8W	28480	0698-3428	1
0698-3438	R:FXD MET FLM 147 OHM 1% 1/8W	28480	0698-3438	1
0698-3441	R:FXD MET FLM 215 OHM 1% 1/8W	28480	0698-3441	2
0698-3444	R:FXD MET FLM 316 OHM 1% 1/8W	28480	0698-3444	1
0698-3454	R:FXD MET FLM 215K OHM 1% 1/8W	28480	0698-3454	1
0698-4466	R:FXD MET FLM 976 OHM 1% 1/8W	28480	0698-4466	1
0757-0198	R:FXD MET FLM 100 OHM 1% 1/2W	28480	0757-0198	1
0757-0199	R:FXD MET FLM 21.5K OHM 1% 1/8W	28480	0757-0199	2
0757-0279	R:FXD MET FLM 3.16K OHM 1% 1/8W	28480	0757-0279	3
0757-0280	R:FXD MET FLM 1K OHM 1% 1/8W	28480	0757-0280	3
0757-0289	R:FXD MET FLM 13.3K OHM 1% 1/8W	28480	0757-0289	1
0757-0346	R:FXD MET FLM 10 OHM 1% 1/8W	28480	0757-0346	2
0757-0401	R:FXD MET FLM 100 OHM 1% 1/8W	28480	0757-0401	1
0757-0439	R:FXD MET FLM 6.81K OHM 1% 1/8W	28480	0757-0439	1
0757-0442	R:FXD MET FLM 10.0K OHM 1% 1/8W	28480	0757-0442	11
0757-0461	R:FXD MET FLM 68.1K OHM 1% 1/8W	28480	0757-0461	6
0757-0465	R:FXD MET FLM 100K OHM 1% 1/8W	28480	0757-0465	7
0757-0470	R:FXD MET FLM 162K OHM 1% 1/8W	28480	0757-0470	1
0757-0835	R:FXD MET FLM 6.81K OHM 1% 1/2W	28480	0757-0835	1
0757-1094	R:FXD MET FLM 1.47K OHM 1% 1/8W	28480	0757-1094	1
0811-2277	R:FXD WW 10K OHM 0.1% 1/40W	28480	0811-2277	2
0811-2537	R:FXD WW 5K OHM 0.1% 1/4W	28480	0811-2537	1
1853-0001	TRANSISTOR:PNP SILICON 30V 900MW	28480	1853-0001	1
1853-0012	TRANSISTOR:PNP SILICON 2N2904A	04713	2N2904A	1
1853-0015	TRANSISTOR:SILICON PNP 2N3640	28480	1853-0015	1
1853-0020	TRANSISTOR:SILICON PNP	28480	1853-0020	9
1854-0003	TRANSISTOR:NPN SILICON	28480	1854-0003	1
1854-0005	TRANSISTOR:SILICON NPN 2N708	02735	2N708	3

See introduction to section VI for ordering information

Table A1-2. Replaceable Parts (Cont'd)

Part No.	Description #	Mfr.	Mfr. Part No.	TQ
854-C062	TRANSISTOR: SILICON NPN 2N1701	02735	2N1701	1
854-0071	TRANSISTOR: SILICON NPN	28480	1854-0071	18
901-C026	DIODE: SILICON 0.75A 200 PIV	28480	1901-0026	5
901-0040	DIODE: SILICON 30MA 30WV	28480	1901-0040	9
902-C033	DIODE BREAKDOWN: 6.2V	04713	1N823	1
100-1769	R: VAR WW 50 OHM 10% LIN 1/2W	28480	2100-1769	1
100-1773	R: VAR WW 1K OHM 10% LIN 1/2W	28480	2100-1773	1
0432-2002	BOARD: BLANK PC	28480	00432-2002	1
0432-6002	BOARD ASSY: LOGIC	28480	00432-6002	1

See introduction to section VI for ordering information

MANUAL CHANGES

MODEL 432A POWER METER

Manual Serial Prefixed: 914 Manual Printed: Feb 1969

MAKE ALL CORRECTIONS IN THIS MANUAL ACCORDING TO ERRATA BELOW, THEN CHECK THE FOLLOWING TABLE FOR YOUR INSTRUMENT SERIAL PREFIX (3 DIGITS) OR SERIAL NUMBER (8 DIGITS) AND MAKE ANY LISTED CHANGE(S) IN THE MANUAL

► NEW ITEM.

SERIAL PREFIX OR NUMBER	MAKE MANUAL CHANGES	SERIAL PREFIX OR NUMBER	MAKE MANUAL CHANGES
► 904, 919	ERRATA		

ERRATA:

- Page 3-3, Paragraph h: Bracket the equation as follows:

$$P_{RF} = \frac{1}{4R} \left[\frac{2V_{COMP} (V_1 - V_0) + V_0^2 - V_1^2}{\text{EFFECTIVE EFFICIENCY}} \right]$$

Page 3-7, Figure 3-3:

Delete the words "slow-blow" from number 1.

Change last sentence of number 7 to read "Output impedance is 1000Ω. "

Page 4-2, Paragraph 4-13:

Change " $V_{COMP} = V_{RF}$ " to " $V_{COMP} + V_{RF}$ "

Page 4-4, Figure 4-3, change the value of the following capacitors,

A1C13 at collector and base of A1Q15 to .01 μf.

A1C14 at collector and base of A1Q14 to .01 μf.

- Page 4-6, Figure 4-4:

Change the stock number of Q37 to 1853-0020,

Page 6-2, Table 6-1, change as follows:

Delete:

A1C13, 0160-2264 C : FXD CER 20 pF 5%, 500 VDCW

A1C14, 0160-2264 C : FXD CER 20 PF 5%, 500 VDCW

Add:

A1C13, 0160-2930 C: FXD CER .01 μf +80-20% 100 VDCW

A1C14, 0160-2930 C : FXD CER .01 μf + 80-20% 100 VDCW

Page 6-9, Table 6-1, change as follows:

R1 2100-2659 R: VAR WW 50K OHM 5% LIN 1-1/2 W (SERIAL PREFIX 904 and below)

- R1 2100-2849 R: VAR WW 50K OHM 5% LIN 1-1/2 W (SERIAL PREFIX 919 and above)

Page 6-12, Table 6-2, change as follows:

Delete: 0160-2264 C: FXD CER 20 pF 5%, 500 VDCW

Add: 2 to the TQ column for 0160-2930

Page 7-3, Figure 7-1, change as follows:

Delete test point 7 from voltage-to-time converter

Page 7-5, Figure 7-7, Assy A1, change as follows:

Delete: 5. 2V from test point 7 and 2.

ADD : 1. 2V for test point 7.
5. 2V for test point 2.

Page 7-11, Figure 7-9, change as follows:

Change the value of A1C13 and A1C14 to .01 μ f.

► Page 7-13/7-14, Figures 7-11 and 7-12.

Delete page 7-13/7-14, Figures 7-11 and 7-12,

Add new page 7-13/7-14, Figures 7-11 and 7-12 (an attached sheet)

APPENDIX B
BASIC ISSUE ITEMS LIST

Basic issue items list will be published at a later date.

APPENDIX C

MAINTENANCE ALLOCATION CHART

Section I. INTRODUCTION

C-1. General.

This Maintenance Allocation Chart designates overall responsibility for the performance of maintenance functions on the identified end item or component. The implementation of field maintenance tasks upon this end item or component will be consistent with the assigned maintenance operations.

C-2 . Maintenance Functions.

Maintenance functions will be limited to and defined as follows:

a. Insect To determine serviceability of an item by comparing its physical, mechanical and electrical characteristics with established standards.

b. Test To verify serviceability and to detect electrical or mechanical failure by use of test equipment.

c. Service To clean, to preserve, to charge and to add fuel, lubricants, cooling agents, and air, If it is desired that elements, such as painting and lubricating, be defined separately, they may be so listed.

d. Adjust To rectify to the extent necessary to bring into proper operating range.

e. Align To adjust specified variable elements of an item to bring to optimum performance.

f. Calibrate To determine the corrections to be made in the readings of instruments or test equipment used in precise measurement, Consists of the comparison of two instruments, one of which is a certified standard of known accuracy, to detect and adjust any discrepancy in the accuracy of the instrument being compared with the certified standard.

g. Install To set up for use in an operational environment such as an emplacement, site, or vehicle.

h. Replace To replace unserviceable items with serviceable like items.

i. Repair Those maintenance operations necessary to restore an item to serviceable condition through correction of material damage or a specific failure. Repair may be accomplished at each category of maintenance.

i. Overhaul. Normally, the highest degree of maintenance performed by the Army in order to minimize time work in process is consistent with quality and economy of operation. It consists of that maintenancs necessary to restore an item to completely serviceable condition as prescribed by maintenance standards in technical publications for each item of equipment. Overhaul normally does not return an item to like new, zero mileage, or zero hour condition.

k. Rebuild. The highest degree of material maintenance. It consists of restoring equipment as nearly as possible to new conditon in accordance with original manufacturing standards. Rebutld is performed only when required by operational considerations or other paramount factors and then only at the depot maintenance category. Rebuild reduces to zero the hours or miles the equipment, or component thereof, has been in use.

l. Symbols The upppercase letter placed in the appropriate column indicates the lowest level at which that particular maintenance function is to be performed.

C-3. Explanation of Columns.

Listed below is an explanation of the columns shown in the maintenance allocation chart:

a. Column 1, Group Number. Column 1 lists group numbers, the purpose of which is to identify components, assemblies, subassemblies and modules with the next higher assembly.

b. Column 2, Functional Group. Column 2 lists the noun names of components asseblies, subassemblies and modules on which maintenance is authorized.

c. Column 3, Maintenance Functions. Column 3 lists the lowest level at which that particular maintenance function is to be performed.

d. Column 4, Tools and Equipment. This column shall be used to specify, by code, those tools and test equipment required to perform the designated function.

e. Column 5, Remarks. Self-explanatory.

Nomenclature of End Item or Component

POWER METER HP 432A and THERMISTOR MOUNT HP 478A

SECTION II - MAINTENANCE ASSIGNMENT

(1) Group Number	Component Assembly Nomenclature (2)	Maintenance Function (3)										Tools and Equipment (4)	Remarks (5)	
		Inspect	Test	Service	Adjust	Align	Calibrate	Install	Replace	Repair	Overhaul			Rebuild
1	POWER METER	F	F	F	F	.	F	.	.	F	.	.		Repair and calibration to be performed in AN/TSM-55V5 Maintenance Calibration Equipment Shelter.
2	THERMISTOR MOUNT	F	F	F	.	.	F	.	F	.	.	.		

LEGEND:

- C - OPERATOR/CREW
- O - ORGANIZATIONAL MAINT.
- F - DIRECT SUPPORT MAINT.
- H - GENERAL SUPPORT MAINT.
- D - DEPOT MAINT.

APPENDIX D

REPAIR PARTS LIST

D-1. This appendix provides a list of repair parts for maintenance support of the equipment. The parts along with their descriptions are listed in table D-1 below.

D-2. Instructions for 'requisitioning parts not identified by Federal. Stock Numbers require the following information be furnished to the Supply officer:

a. Manufacturer's Federal Supply Code Number.

b. Manufacturer's identification number,

c. Manufacturer's nomenclature.

d. Any other information as listed on parts list that will aid in identification of the item being requisitioned.

D-3. If DD Form 1348 is used, fill in all blocks except 4, 5, 6 and Remarks field in accordance with AR 725-50. Complete Form as follows:

a. In Blocks 4, 5 and 6 list Manufacturer's Federal Supply Code Number followed by a colon and the Manufacturer's part number.

b. Complete Remarks Field as follows; Nomenclature of the repair part and any other identification to assist Supply Officer in procurement.

D-4. Report of errors, omissions and recommendations for improving this publication by the individual user is encouraged. Reports should be submitted on DA Form 2028 (Recommended Changes to DA Publications) and forwarded direct to Commanding Officer, Frankford Arsenal., ATTN: AMSWE-SMF-W3100, Philadelphia, Pa. 19137.

Table D-1. Repair Parts List for Power Meter 432A

Part No.	Description	Mfr. Federal Supply Code	Mfr. Part No.	Total Qty	FSN
0140-0198	C:FXD MICA 200 PF 5%	28480	0140-0198	1	
0140-0234	C:FXD MICA 500 PF 1%	28480	0140-0234	1	5910-494-5056
0150-0059	C:FXD CER 3.3-0.25 PF 500VDCW	72982	301-000-COJO-339C	1	
0150-0380	C:FXD MY 0.22 UF 10% 200VDCW	28480	0150-0330	1	5910-586-5233
0150-0973	C:FXD MICA 1500 PF 1% 500VDCW	28480	0160-0978	1	
0160-2143	C:FXD CER 2000 PF +80-20% 1000VDCW	91418	Type B	1	
0160-2264	C:FXD CER 20 PF 5% 500VDCW	72982	301-000-30G0-200J	1	5910-318-8758
0150-2265	C:FXD CER 22 PF 5% 500VDCW	72982	301-NP0-22PF	1	
0160-2672	C:FXD MY 0.047 UF 5% 80VDCW	28480	0160-2672	1	
0150-2917	C:FXD CER 0.35 UF +80-20% 100VDCW	84411	Type TA	1	
0160-2930	C:FXD CER 0.01 UF +80-20% 100VDCW	91418	TA	2	5910-194-3010
0160-3043	C:FXD CER 2 X 0.005 UF 20% 250VAC	56289	29C147A-CDH	1	
0180-0106	C:FXD ELECT TA 60UF 20% 6VDCW	56289	150D606X0006B2	1	5910-127-1668
0180-0197	C:FXD ELECT 2.2 UF 10% 20VDCW	56289	150D225X9020A2	1	
0180-0229	C:FXD ELECT 33 UF 10% 10VDCW	28480	0180-0229	1	
0180-0291	C:FXD ELECT 1UF 10% 35VDCW	56289	150D105X9035A2	1	5910-931-7055
0180-0374	C:FXD ELECT 10 UF 10% 20VDCW	28480	0180-0374	1	5910-931-7050
0180-1746	C:FXD ELECT 15 UF 10% 20VDCW	56289	150D156X9020B2	1	
0180-1819	C:FXD ELECT 100 UF +75-10% 50VDCW	28480	0180-1819	1	
0180-1940	C:FXD ELECT 33 UF 10% 15VDCW	56289	109D336X9015C2- DYP	1	
0180-2178	C:FXD ELECT 220 UF 20% 3VDCW	56289	109D227X0008F2- DYP	1	
0360-0124	TERMINAL:SOLDER LUG	28480	0360-0124	3	5940-993-9338

Table D-1. Repair Parts List for Power Meter 432A (Continued)

	Description	Mfr. Federal Supply Code	Mfr. Part No.	Total Qty	FSN
0683-0685	R:FXD COMP 5.8 OHM 5% 1/4W	01121	CB68G5	1	5905-461-8385
0686-1055	R:FXD COMP 1 MEGOHM 5% 1/2W	01121	EB 1055	1	5905-577-9667
0698-0084	R:FXD MET FLM 2.15K OHM 1% 1/8W	28480	0698-0084	1	5905-974-6073
0698-3136	R:FXD MET FLM 17.8K OHM 1% 1/8W	28480	0698-3136	1	5905-891-4247
0698-3155	R:FXD MET FLM 4.64K OHM 1% 1/8W	28480	0698-3155	1	5905-976-3418
0698-3156	R:FXD MET FLM 14.7K OHM 1% 1/8W	28480	0698-3156	1	5905-974-6084
0698-3160	R:FXD MET FLM 31.6K OHM 1% 1/8W	28480	0698-3160	3	5905-974-6078
0698-3260	R:FXD MET FLM 464K OHM 1% 1/8W	28480	0698-3260	2	5905-998-1809
0698-3401	R:FXD MET FLM 215 OHM 1% 1/2W	28480	0698-3401	1	
0698-3428	R:FXD MET FLM 14.7 OHM 1% 1/8W	28480	0698-3428	1	5905-891-4238
0698-3438	R:FXD MET FLM 147 OHM 1% 1/8W	28480	0698-3438	1	5905-974-6080
0698-3441	R:FXD MET FLM 215 OHM 1% 1/8W	28480	0698-3441	1	5905-974-6076
0698-3444	R:FXD MET FLM 316 OHM 1% 1/8W	28480	0698-3444	1	5905-974-6074
0698-3454	R:FXD MET FLM 215K OHM 1% 1/8W	28480	0698-3454	1	5905-974-6077
0698-3635	R:FXD MET OX 680 OHM 5% 2W	28480	0698-3635	1	
0698-4466	R:FXD MET FLM 976 OHM 1% 1/8W	28480	0698-4466	1	
0698-6635	R:FXD MET FLM 880 OHM 1% 1/8W	28480	0698-6635	1	
0757-0198	R:FXD MET FLM 100 OHM 1% 1/2W	28480	0757-0198	1	5905-830-6188
0757-0199	R:FXD MET FLM 21.5K OHM 1% 1/8W	28480	0757-0199	1	5905-981-7513

Table D-1. Repair Parts List for Power Meter 432A (Continued)

Part No.		Federal Supply Code	Mfr. Part No.	Total Qty	FSN
0757-0279	R:FXD MET FLM 3.16K OHM 1% 1/8W	28480	0757-0279	1	5905-221-8310
0757-0230	R:FXD MET FLM 1K OHM 1% 1/8W	28480	0757-0230	1	5905-853-8190
0757-0239	R:FXD MET FLM 13.3K OHM 1% 1/8W	28480	0757-0239	1	5905-998-1908
0757-0346	R:FXD MET FLM 10 OHM 1% 1/8W	28480	0757-0346	3	5905-998-1906
0757-0401	R:FXD MET FLM 100 OHM 1% 1/8W	28480	0757-0401	1	
0757-0416	R:FXD MET FLM 511 OHM 1% 1/8W	28480	0757-0416	1	5905-998-1795
0757-0439	R:FXD MET FLM 6.81K OHM 1% 1/3W	28480	0757-0439	1	
0757-0442	R:FXD MET FLM 10.0K OHM 1% 1/8W	28480	0757-0442	2	5905-998-1792
0757-0451	R:FXD MET FLM 68.1K OHM 1% 1/8W	28480	0757-0451	1	5905-089-7577
0757-0455	R:FXD MET FLM 100K OHM 1% 1/8W	28480	0757-0455	2	5905-974-5725
0757-0470	R:FXD MET FLM 152K OHM 1% 1/8W	28480	0757-0470	1	
0757-0835	R:FXD MET FLM 6.81K OHM 1% 1/2W	28480	0757-0835	1	5905-980-3049
0757-1094	R:FXD MET FLM 1.47K OHM 1% 1/8W	28480	0757-1094	1	5905-917-0580
0811-2277	R:FXD WW 10K OHM 0.1% 1/40W	28480	0811-2277	1	
0811-2284	R:FXD WW 1K OHM 0.1% 1/40W	28480	0811-2284	1	5905-858-6516
0811-2534	R:FXD WW 314.3 OHM 0.1% 1/40W	28480	0811-2534	1	
0811-2535	R:FXD WW 145.0 OHM 0.1% 1/40W	28480	0811-2535	1	
0811-2536	R:FXD WW 3167 OHM 0.1% 1/40W	28480	0811-2536	1	
0811-2537	R:FXD WW 5K OHM 0.1% 1/4W	28480	0811-2537	1	
0811-2538	R:FXD WW 100 OHM 0.1% 1/10W	28480	0811-2538	1	
1120-1497	METER	28480	1120-1497	1	
1420-0062	BATTERY:RECHARGEABLE 24V	28480	1420-0062	1	

Table D-1. Repair Parts List for Power Meter 432A (Continued)

Part No.	Description	Mfr. Federal Supply Code	Mfr. Part No.	Total Qty	FSN
1853-0001	TRANSISTOR: PNP SILICON 30V 900MW	28480	1853-0001	2	5961-962-5213
1853-0012	TRANSISTOR: PNP SILICON 2N2904A	04713	2N2904A	1	
1853-0015	TRANSISTOR: SILICON PNP 2N3640	28480	1853-0015	1	5961-927-0845
1853-0020	TRANSISTOR: SILICON PNP	28480	1853-0020	3	5961-904-2540
1854-0003	TRANSISTOR: MPN SILICON	28480	1854-0003	1	5961-990-5369
1854-0005	TRANSISTOR: SILICON NPN 2N708	02735	2N708	2	
1854-0039	TRANSISTOR: SILICON 2N3053	02735	2N3053	1	5961-985-9703
1854-0052	TRANSISTOR: SILICON NPN 2N1701	02735	2N1701	1	5961-082-1617
1854-0071	TRANSISTOR: SILICON NPN	28480	1854-0071	7	5961-928-3161
1854-0221	TRANSISTOR DUAL: SILICON NPN	28480	1854-0221	1	5961-836-1887
1901-0026	DIODE: SILICON 0.75 200 PIV	28480	1901-0026	3	5961-060-8638
1901-0040	DIODE: SILICON 30MA 30VV	28480	1901-0040	3	5961-965-5917AX1
1902-0033	DIODE BREAKDOWN: 6.2V	04713	1N823	1	5961-103-7417
1902-0048	DIODE BREAKDOWN: 6.81V 5%	28480	1902-0048	1	5961-912-3099
2100-1769	R: VAR WW 50 OHM 10% LIN 1/2W	28480	2100-1769	1	5905-891-4230
2100-1770	R: VAR WW 100 OHM 10% LIN 1/2W	28480	2100-1770	1	5905-891-4229
2100-1773	R: VAR WW 1K OHM 10% LIN 1/2W	28480	2100-1773	1	5905-115-7158YA
2100-1775	R: VAR WW 5K OHM 10% LIN 1/2W	28480	2100-1775	1	5905-228-5990YA
2100-2659	R: VAR WW 50K OHM 5% LIN 1-1/2W	28482	2100-2659	1	
2110-0027	FUSE: 0.125A 250V	75915	312.125	1	6240-402-0401
2140-0015	LAMP: GLOW NEON NE-2H	24455	NE 2H	1	

Table D-1. Repair Parts List for Power Meter 432A (Continued)

Part No.	Description				
3100-2469	SWITCH:ROTARY, CALIBRATION FACTOR	28480	3100-2469	1	
3100-2470	SWITCH:ROTARY, RANGE	28480	3100-2470	1	
3101-0033	SWITCH:SLIDE DPOT	79727	6510 C	1	5930-228-5970
3101-0957	SWITCH:TOGGLE DPOT	28480	3101-0957	1	
3101-1180	SWITCH:SLIDE 3POT	82389	11L-1920	1	
3101-1357	SWITCH:MOMENTARY, FINE ZERO	28480	3101-1357	1	
8120-0073	CABLE ASSY:POWER CORD	28480	8120-0073	1	
8120-1082	CABLE ASSY:5 FT, THERMISTOR CABLE	28480	8120-1082	1	

By Order of the Secretary of the Army:

Official:

W. C. WESTMORELAND,
General, United States Army,
Chief of Staff.

KENNETH G. WICKHAM,
Major General, United States Army,
The Adjutant General.

DISTRIBUTION:

To be distributed in accordance with DA Form 12-37 (qty rqr Block #201) Operator requirements for Gun, 20-MM XM163; DA Form 12-40 (qty rqr Block #168), Operator/Crew requirements for Gun, 20-MM XM167.

TEST POINT MEASUREMENT CONDITIONS AND VOLTAGES

Measurement Conditions

1. .3 mW
2. 200 ohm mount
3. 100% CAL FACTOR
4. COARSE ZERO turned to get full-scale deflection
5. Measurements made with respect to CHASSIS GROUND

Test Point Voltages

Test Point	Voltage	Notes
A1TP1	+5.2	
A1TP2	+5.2	
A1TP3	+2.7	
A1TP4	+2.7	
A1TP5	+2.7	
A1TP6	+2.7	
A1TP7	+1.2	RANGE to COARSE ZERO, meter zeroed
A1TP8	-6.5	Varies from 0 to -13 V under normal operating conditions
A1TP9	+4 mV	Thermistor ground
A2TP1	Waveform	Figure 7-3
A2TP2	Waveform	Figure 7-3
A2TP3	+7 Nominal	
A2TP4	-13 Nominal	
A2TP5	0 V	Chassis Ground
A2TP6	Waveform	Figure 7-3
A2TP7	Waveform	Figure 7-3
A2TP8	Waveform	Figure 7-3
A2TP9	Waveform	Figure 7-3
A2TP10	Waveform	Figure 7-3
A7TP1	+1 Variable	
A7TP2	+1.6 Variable	

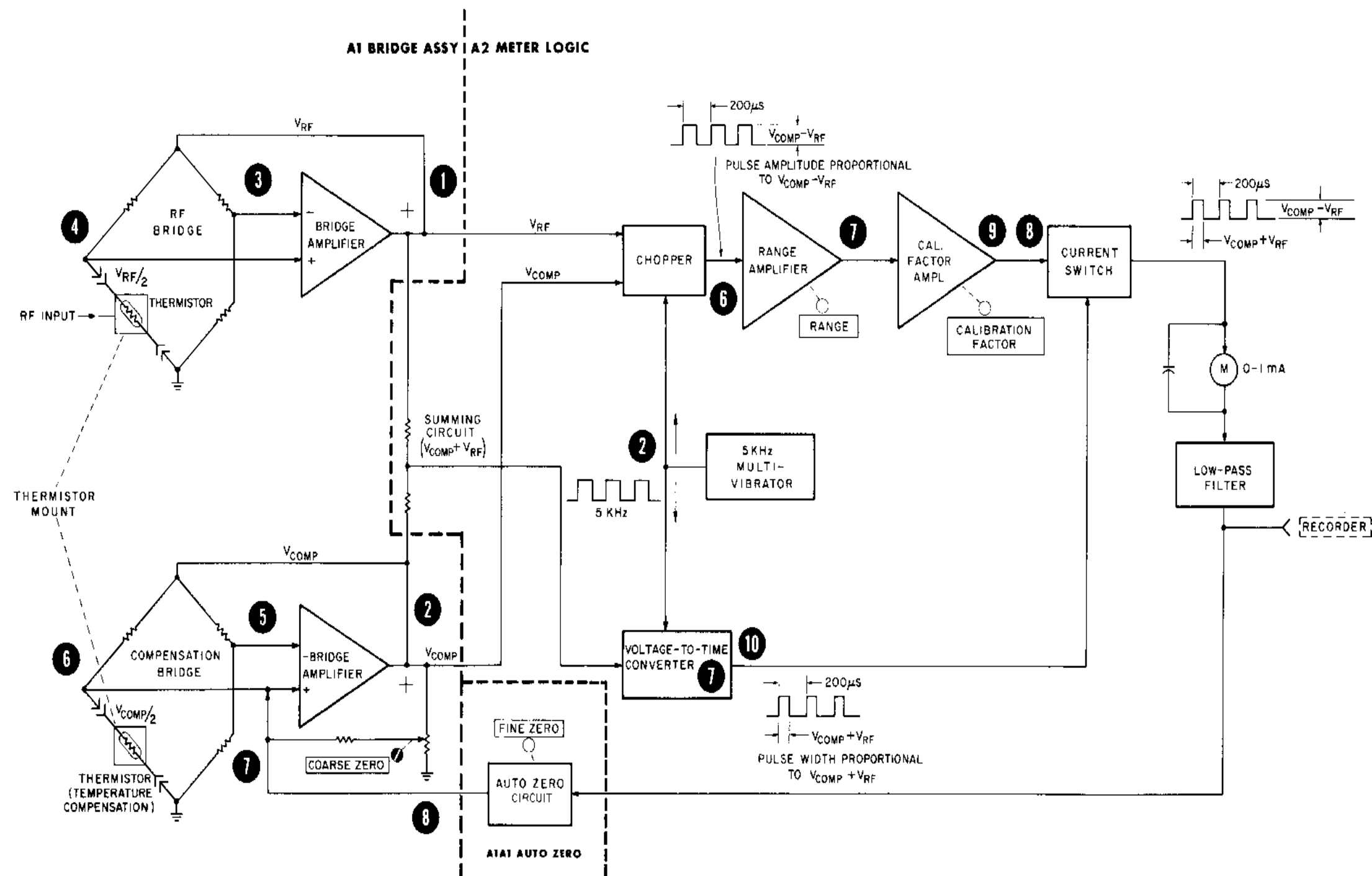

Figure 7-1. Servicing Block Diagram

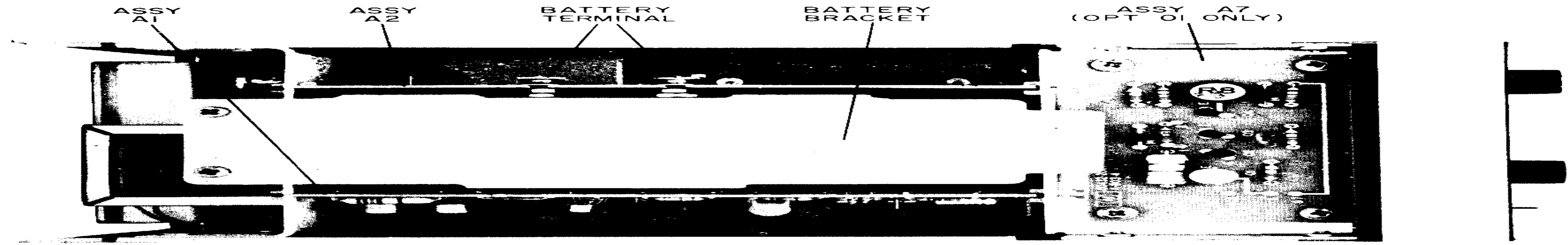

Figure 7-2. Model 432A Top Internal View

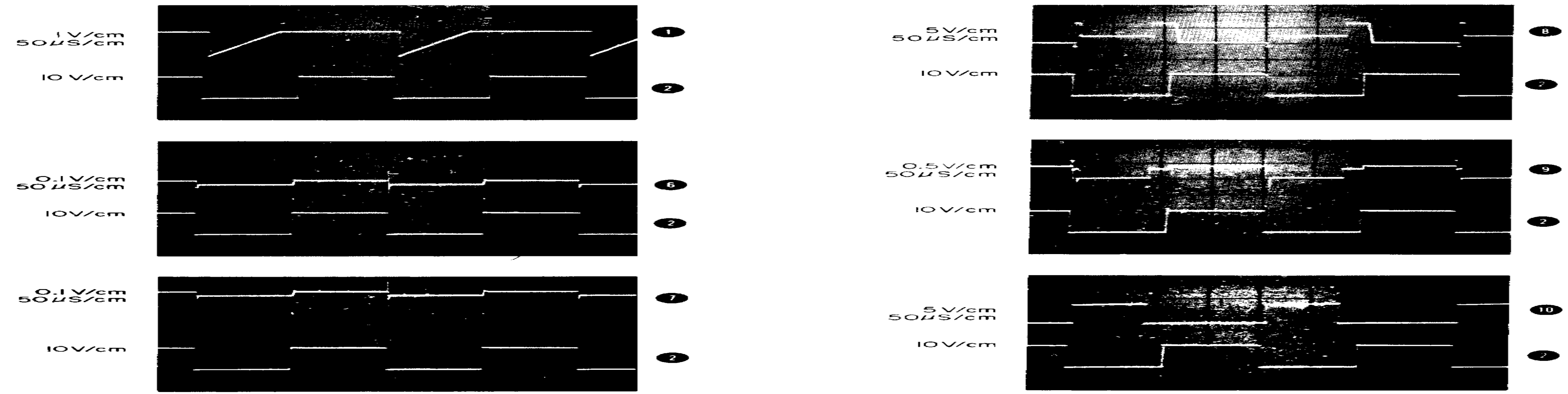

Figure 7-3. Model 432A Waveforms, A2 Meter Logic Assembly

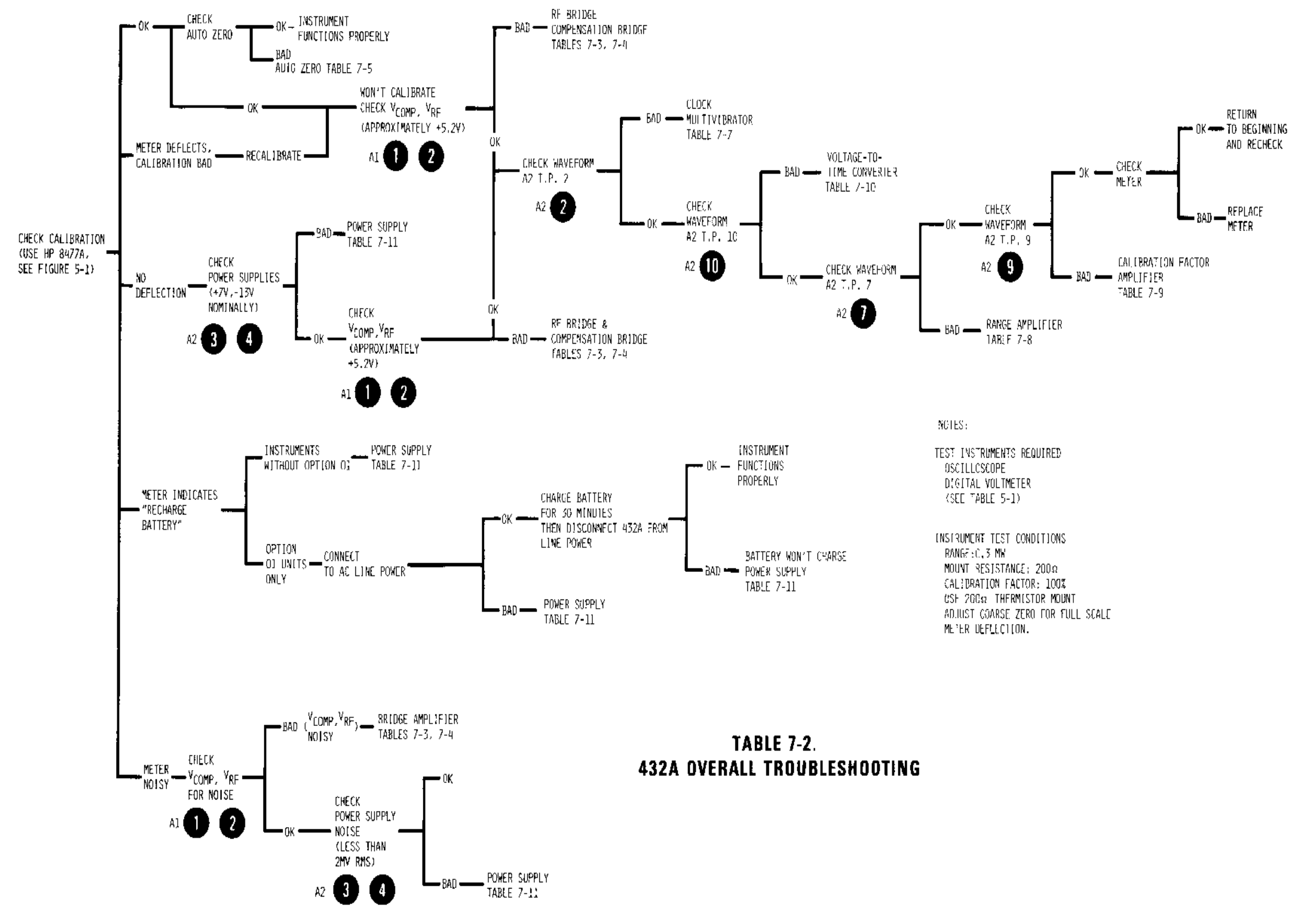
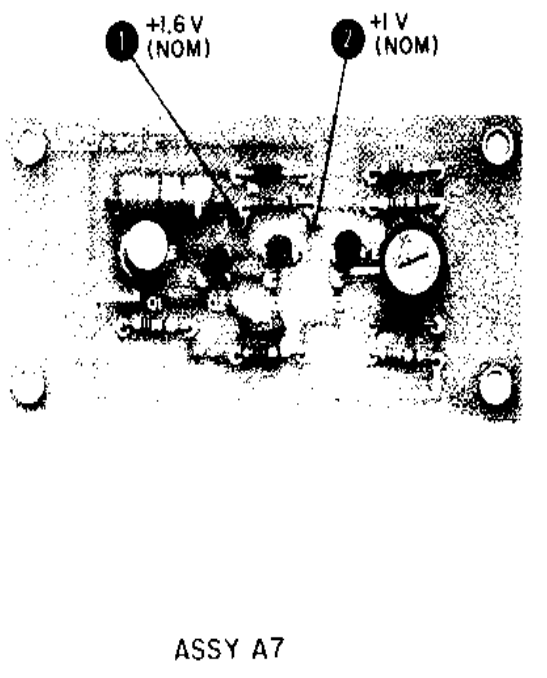
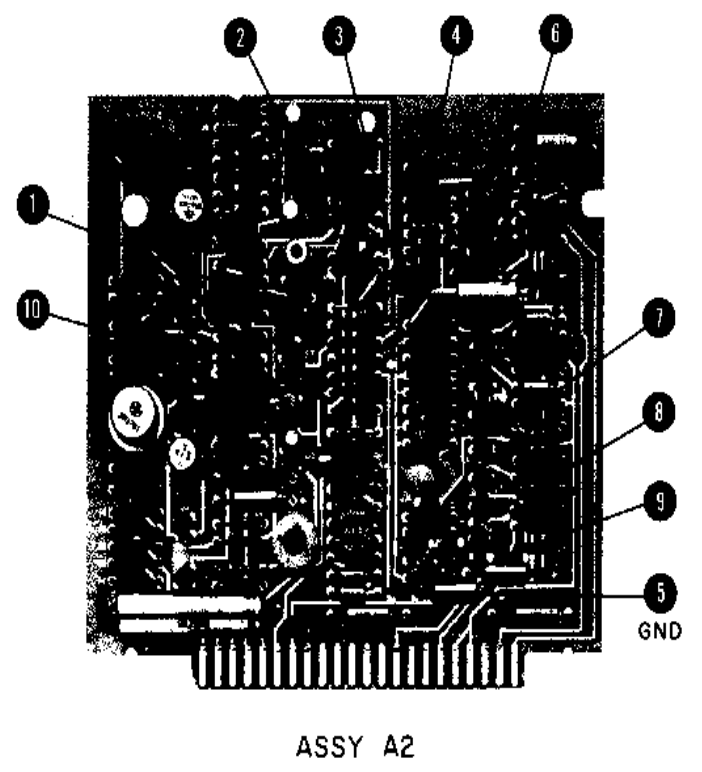
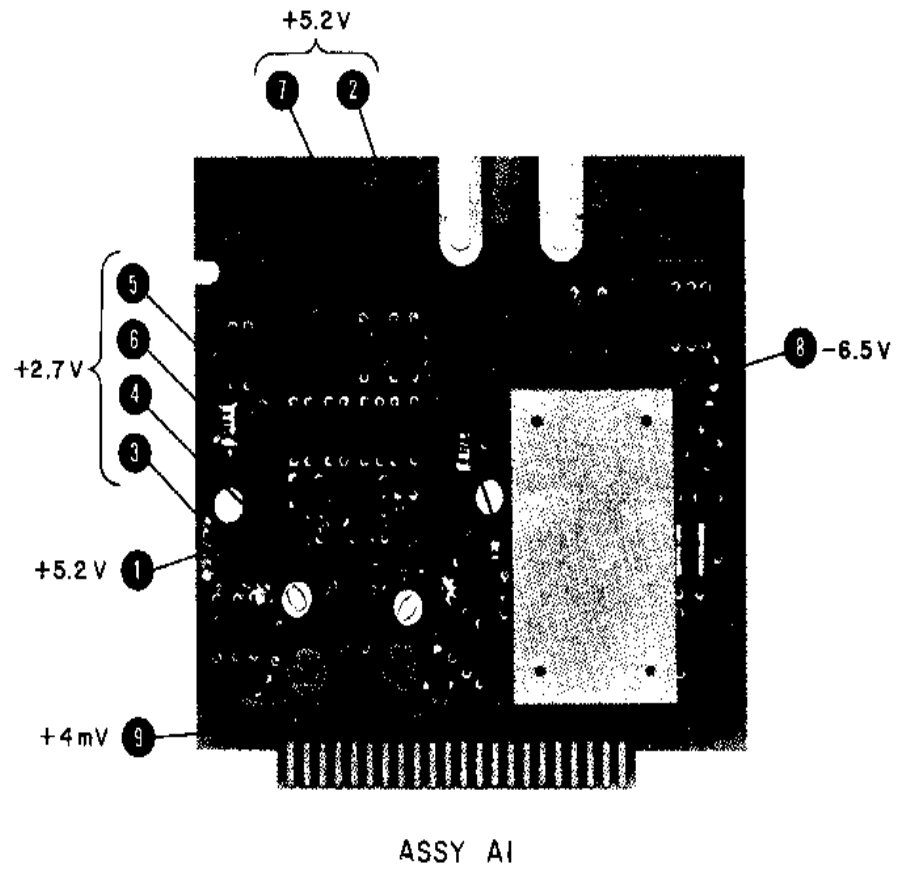
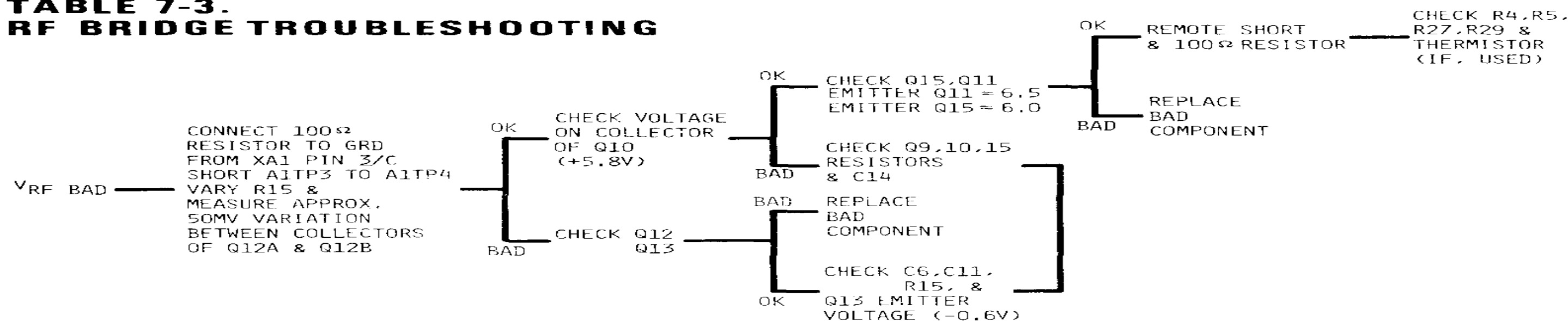

Figure 7-4. Model 432A Test Point Locations

Table 7-2. Overall Troubleshooting

**TABLE 7-3.
RF BRIDGE TROUBLESHOOTING**



NOTE: IF TROUBLESHOOTING RF BRIDGE FOR NOISE, CHECK Q12.

**TABLE 7-4.
COMPENSATION BRIDGE P/O A1 TROUBLESHOOTING**

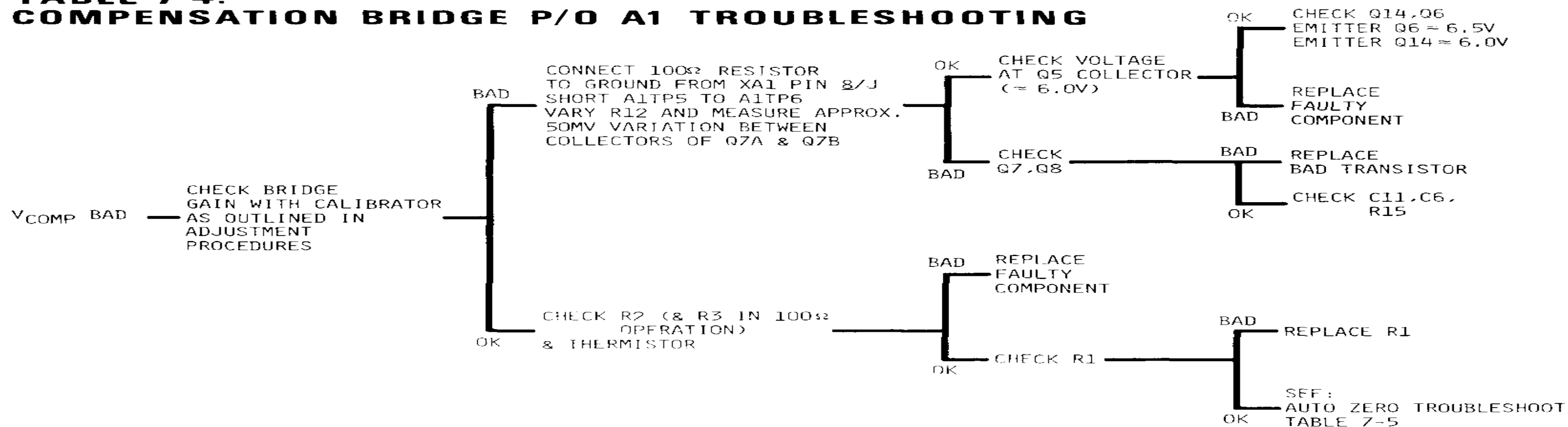

TABLE 7-5.
AUTO ZERO CIRCUIT P/O A1 TROUBLESHOOTING

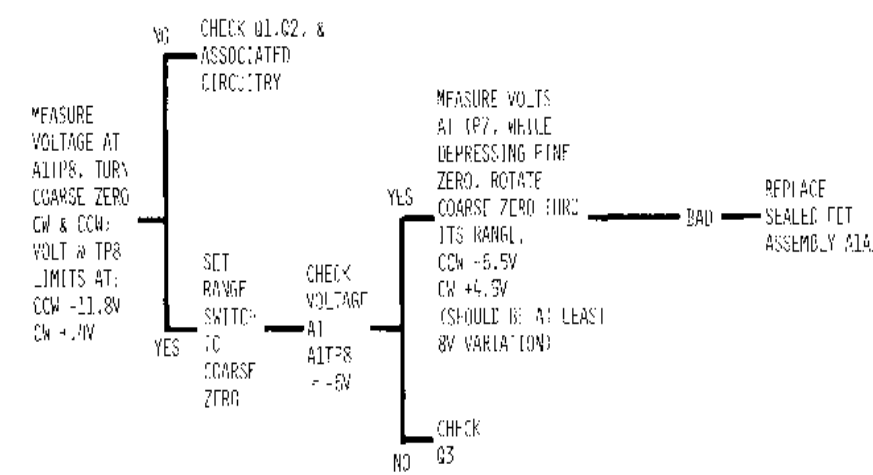
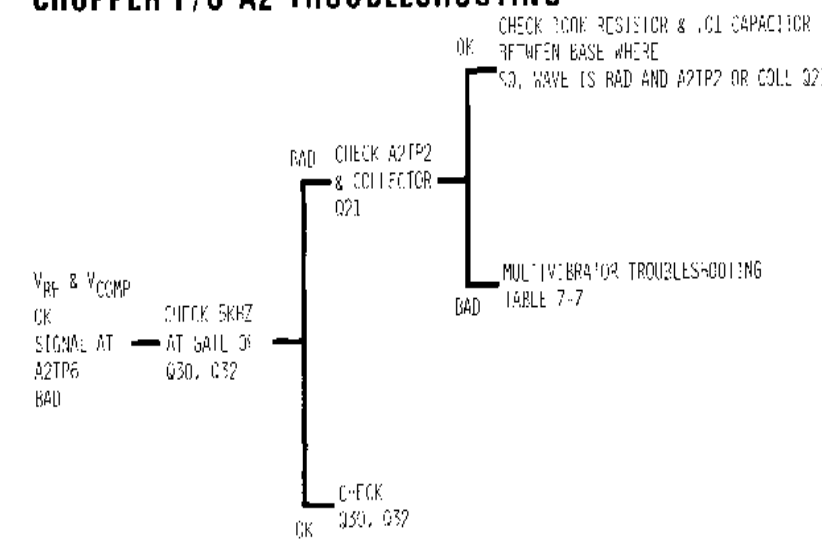

TABLE 7-6.
CHOPPER P/O A2 TROUBLESHOOTING



SERVICE HINT: IF TROUBLESHOOTING CHOPPER FOR NOISE, LEFT END OF C25 & C31 AND SEE IF NOISE PERSISTS.

TABLE 7-7.
MULTIVIBRATOR P/O A2 TROUBLESHOOTING

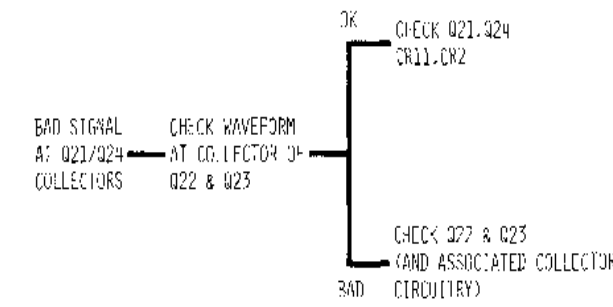

TABLE 7-8.
RANGE AMPLIFIER TROUBLESHOOTING

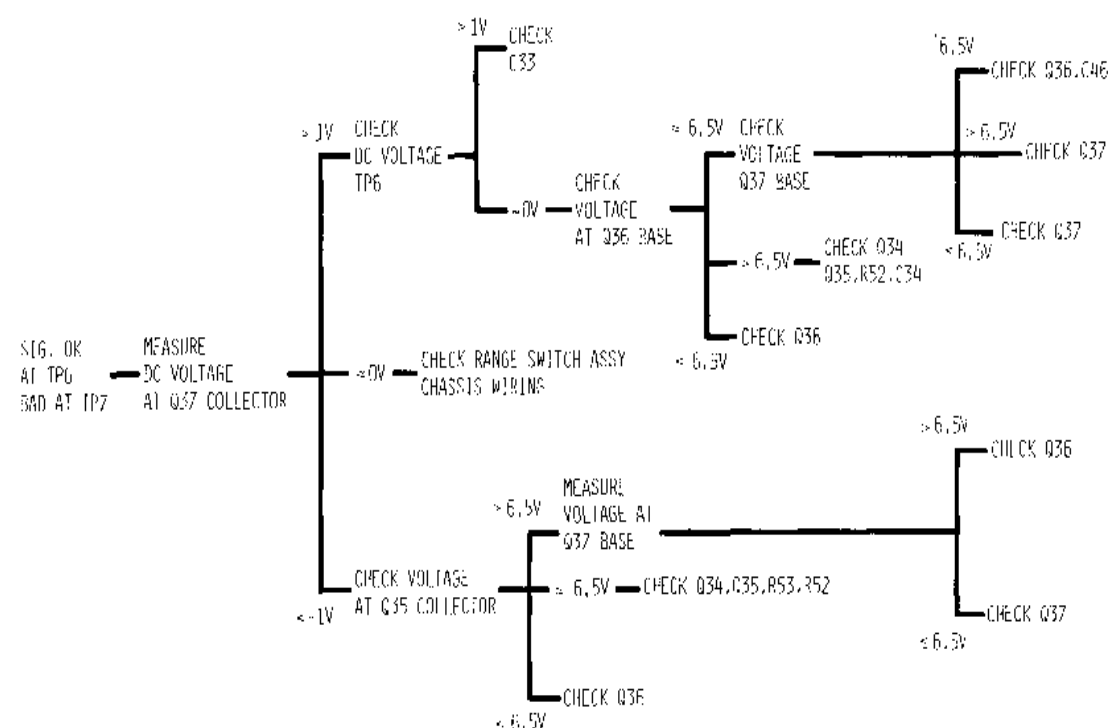
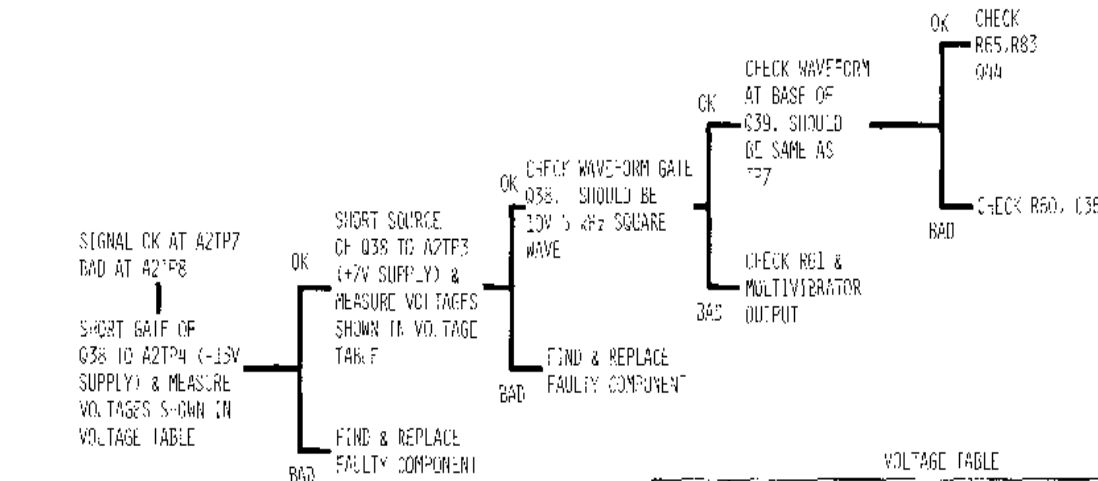

TABLE 7-9.
CALIBRATION FACTOR AMPLIFIER P/O A2 TROUBLESHOOTING



VOLTAGE TABLE

POINT	W/TH GATE OF Q38 TO TP4 VOLTAGE IF BAD, CHECK	W/TH SOURCE OF Q38 TO TP4 VOLTAGE IF BAD, REPLACE
BASE, Q39	-1V Q38, C38, R63	+6.1V Q39, C36
BASE, Q40	+1.4V A4 ASSY, CHASSIS WIRING	-3V Q40
BASE, Q41	+6.63V Q39, Q41, R77, C39	+6.2V Q39, Q41
BASE, Q42	+5.47V Q41	+5.8V Q42
TP8	+6.13V Q4, Q45	0.7V Q42, Q45

TABLE 7-10.
VOLTAGE-TO-TIME CONVERTER & METER TROUBLESHOOTING

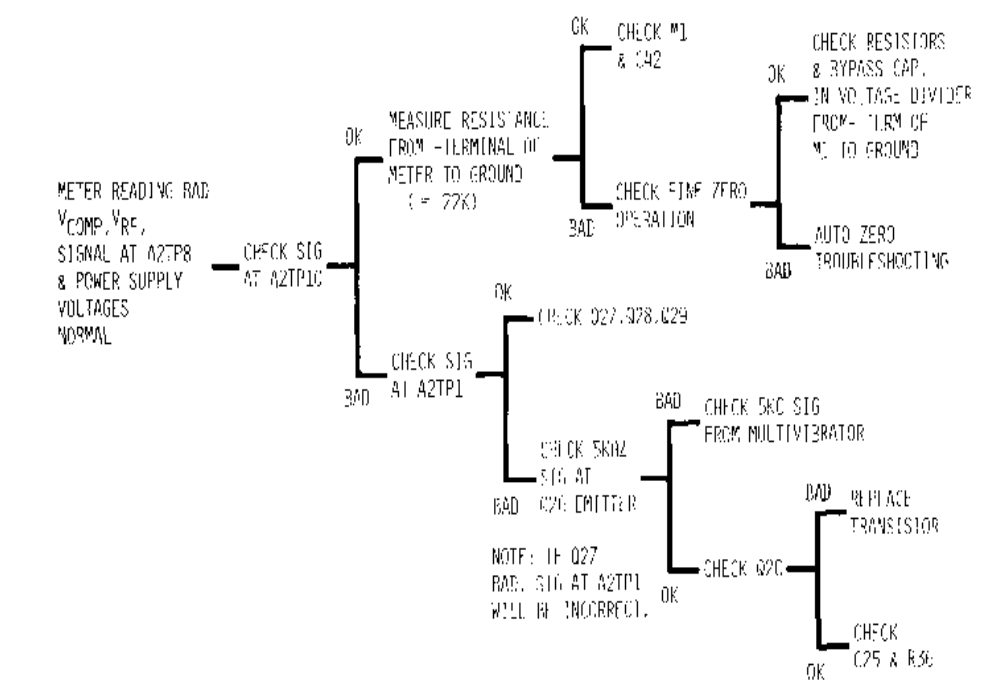
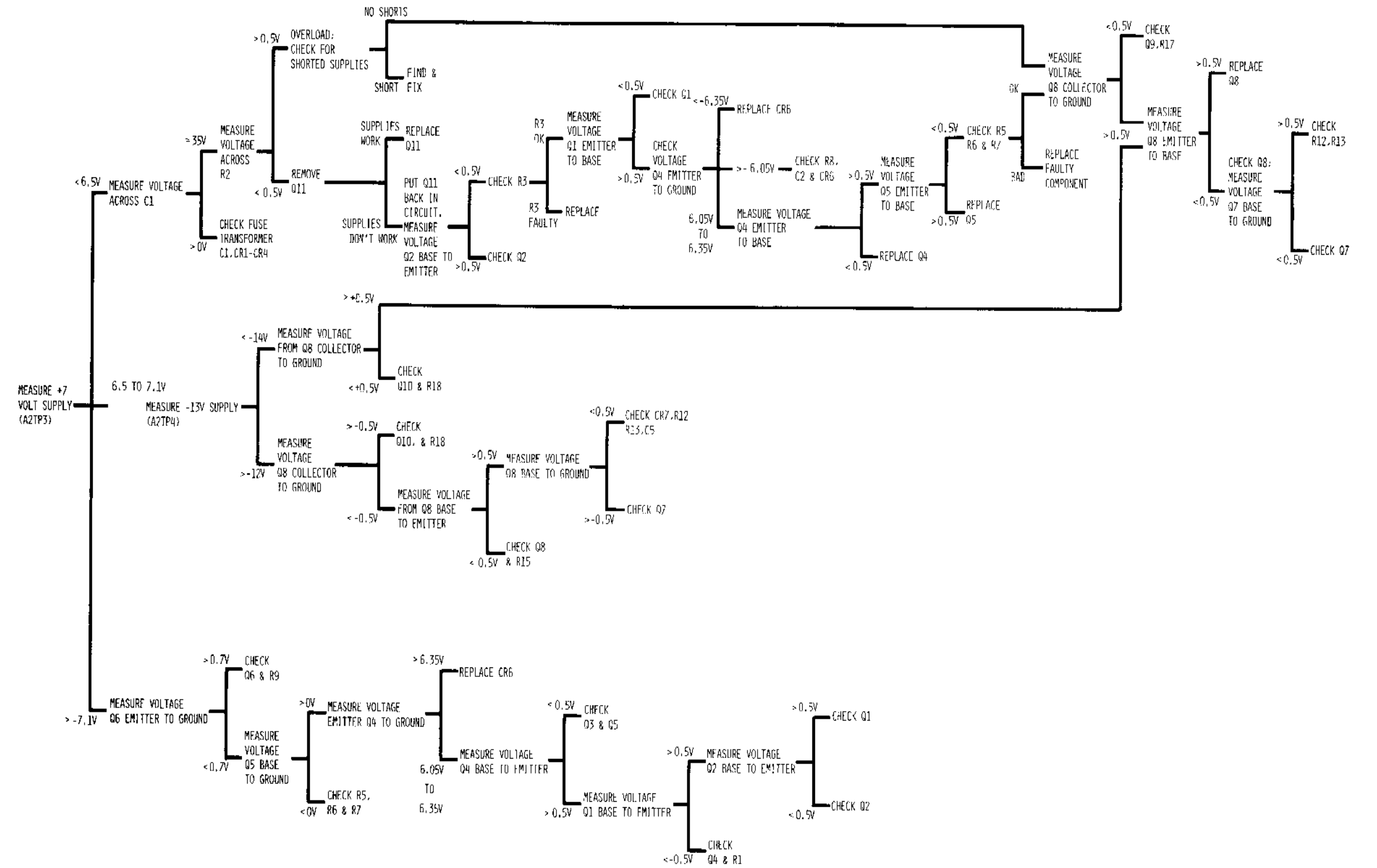

TABLE 7-11.
POWER SUPPLY TROUBLESHOOTING



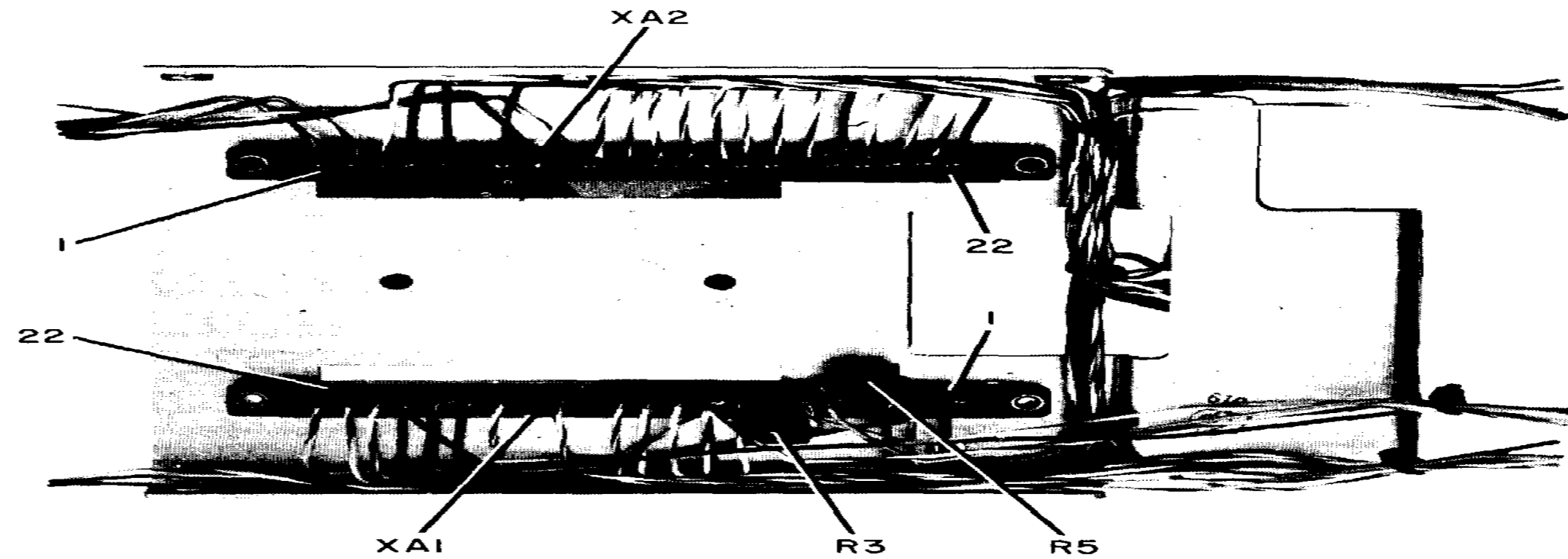

Figure 7-5. 432A Bottom View, Component Locations

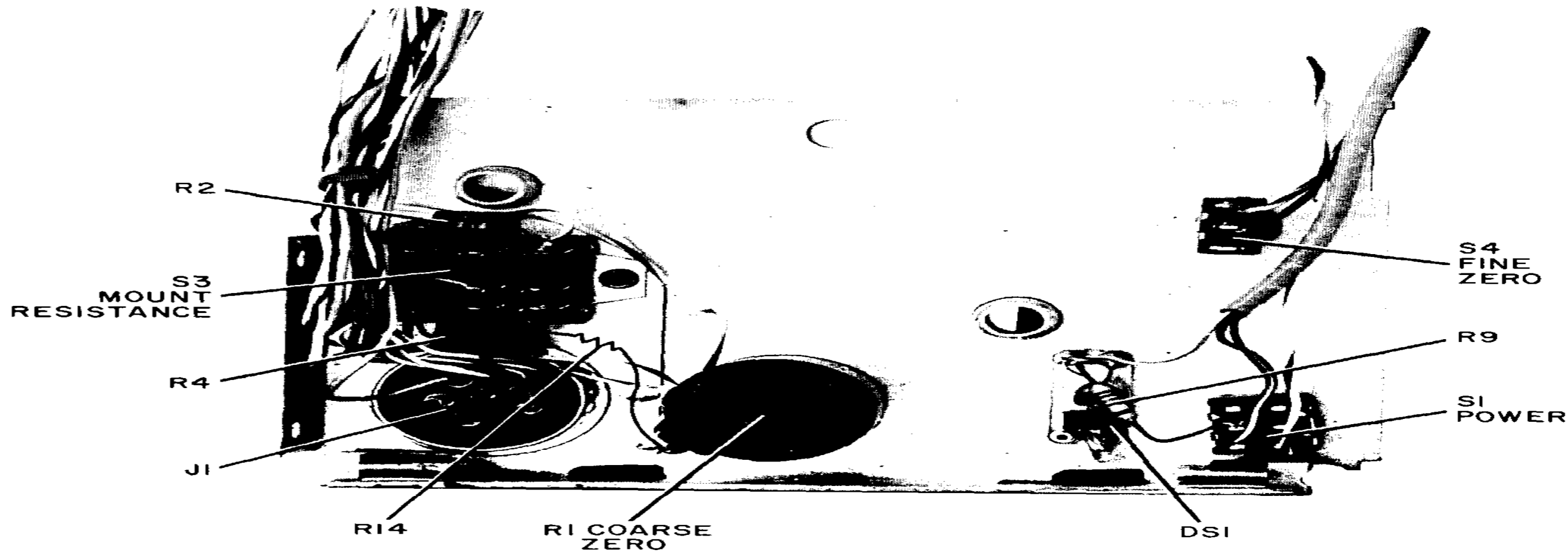

Figure 7-6. 432A Front Panel Interior

** ADDED FOR LONG CABLE OPTIONS (11,12)

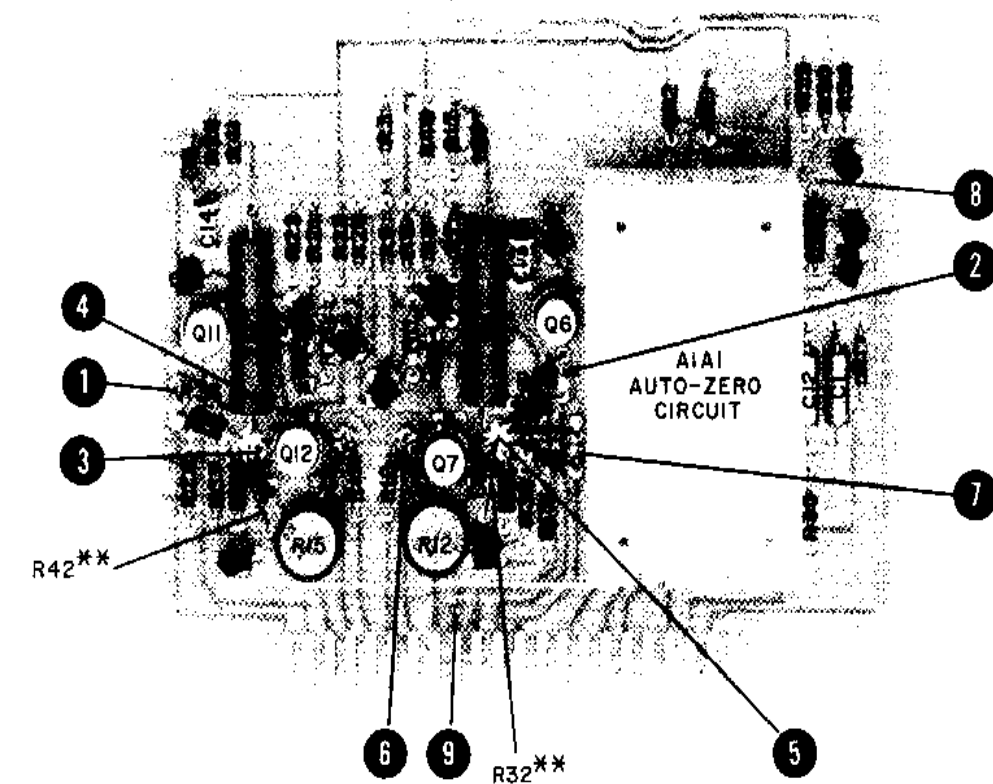

Figure 7-7. A1 Bridge Assembly Component Locations

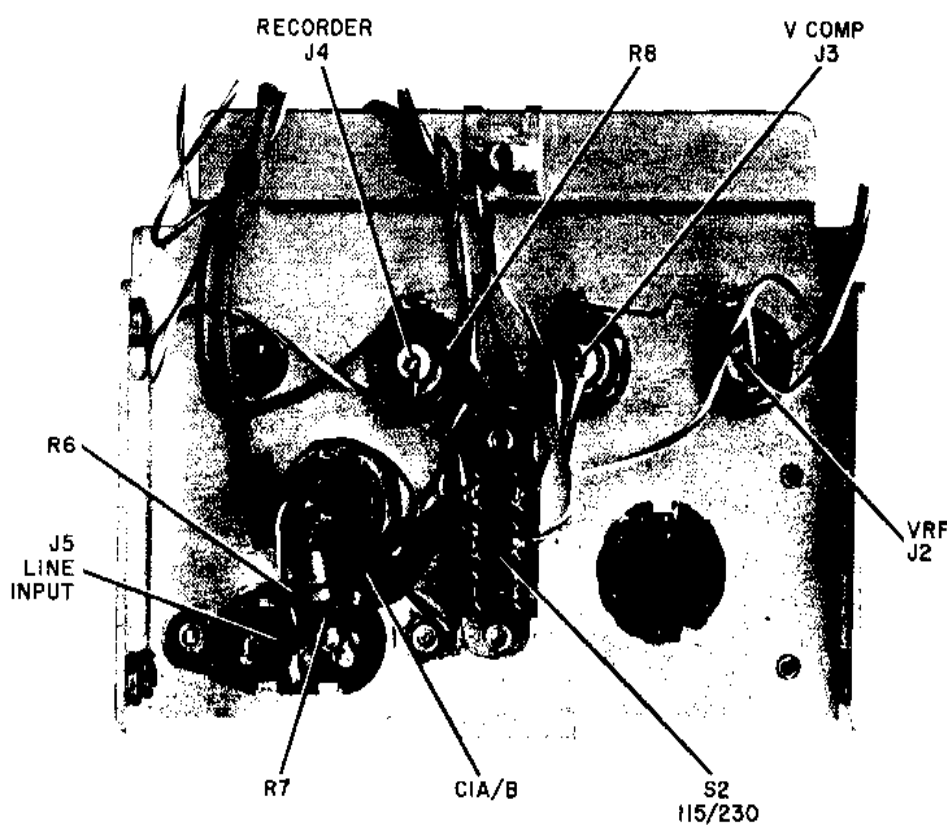

Figure 7-8. 432A Rear Panel Interior

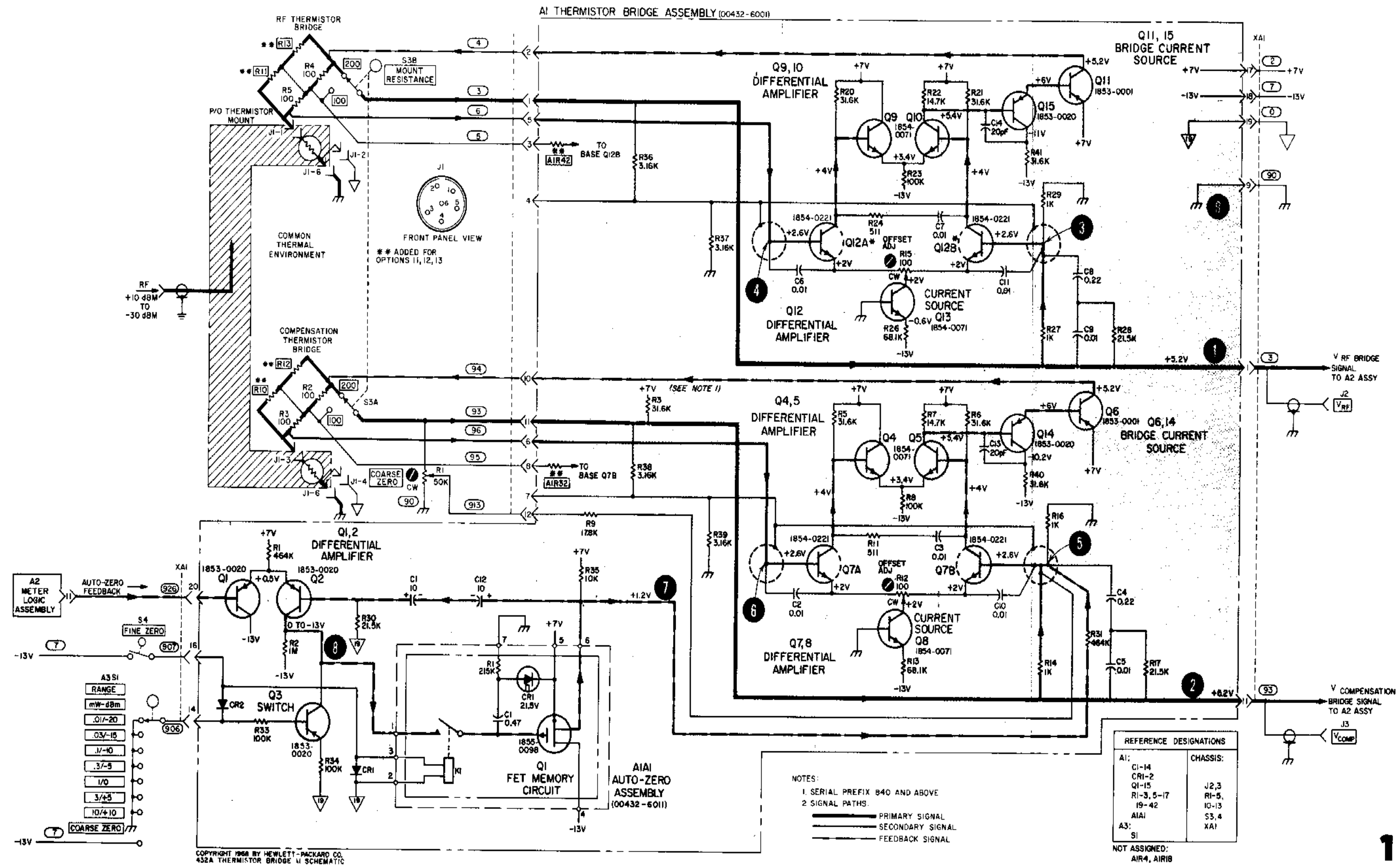

Figure 7-9. RF and Compensation Bridge Schematic

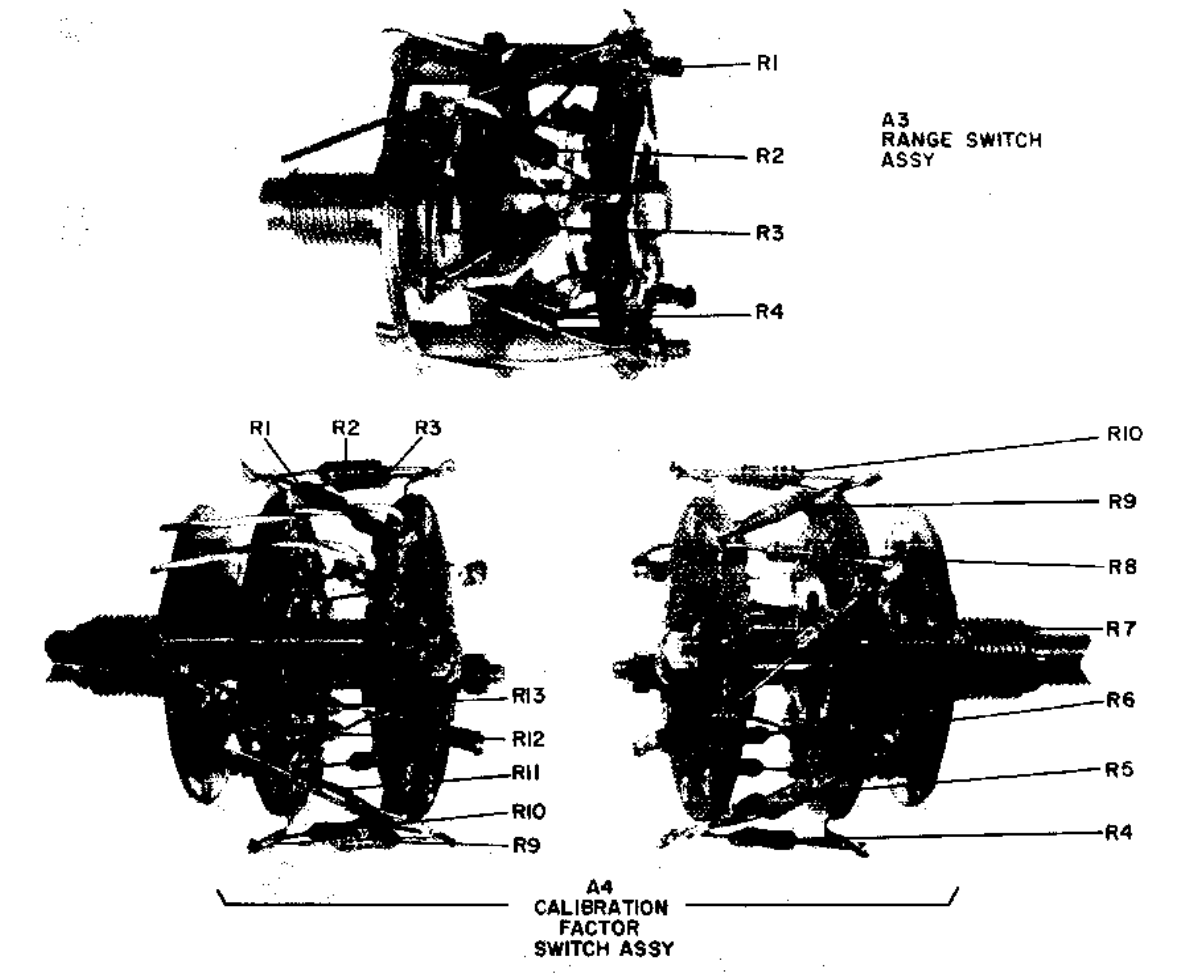

Figure 7-10. Model 432A Switches

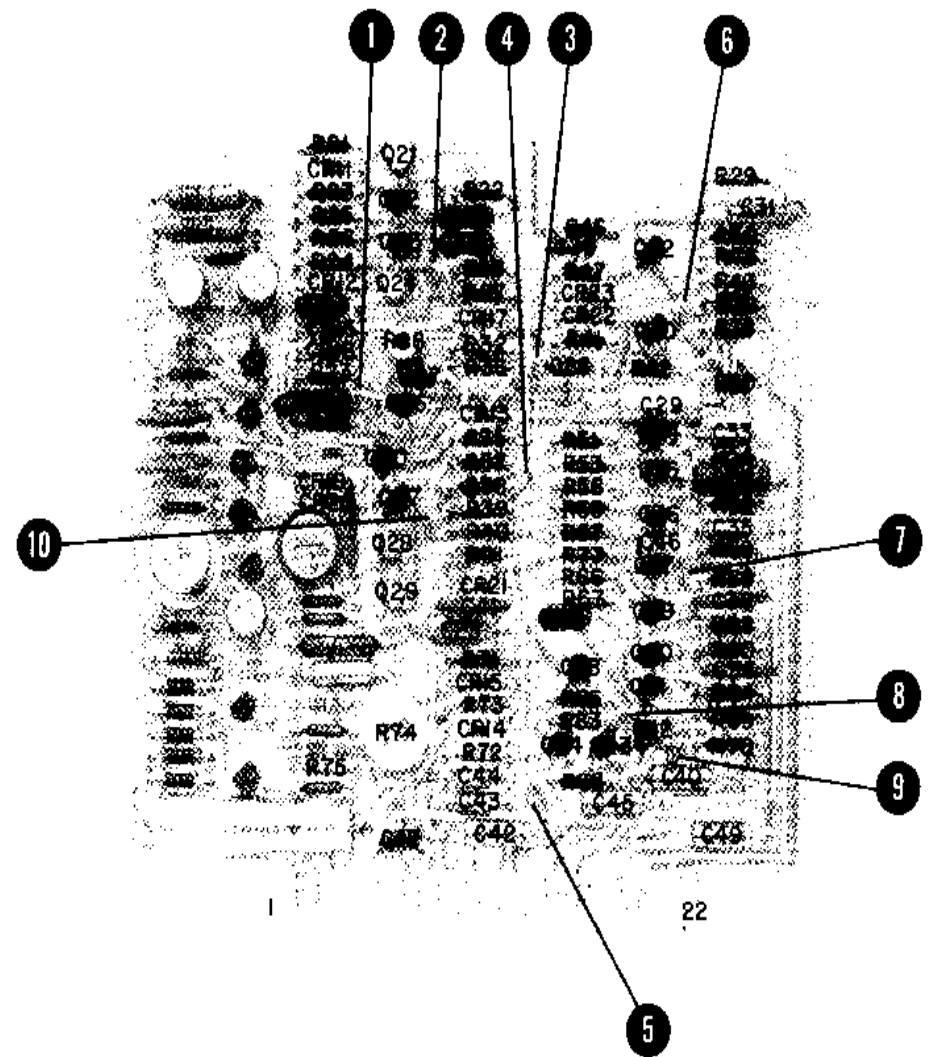

Figure 7-11. A2 Meter Logic Assembly Component Locations

P/O A2 METER LOGIC ASSEMBLY (00432-6018)

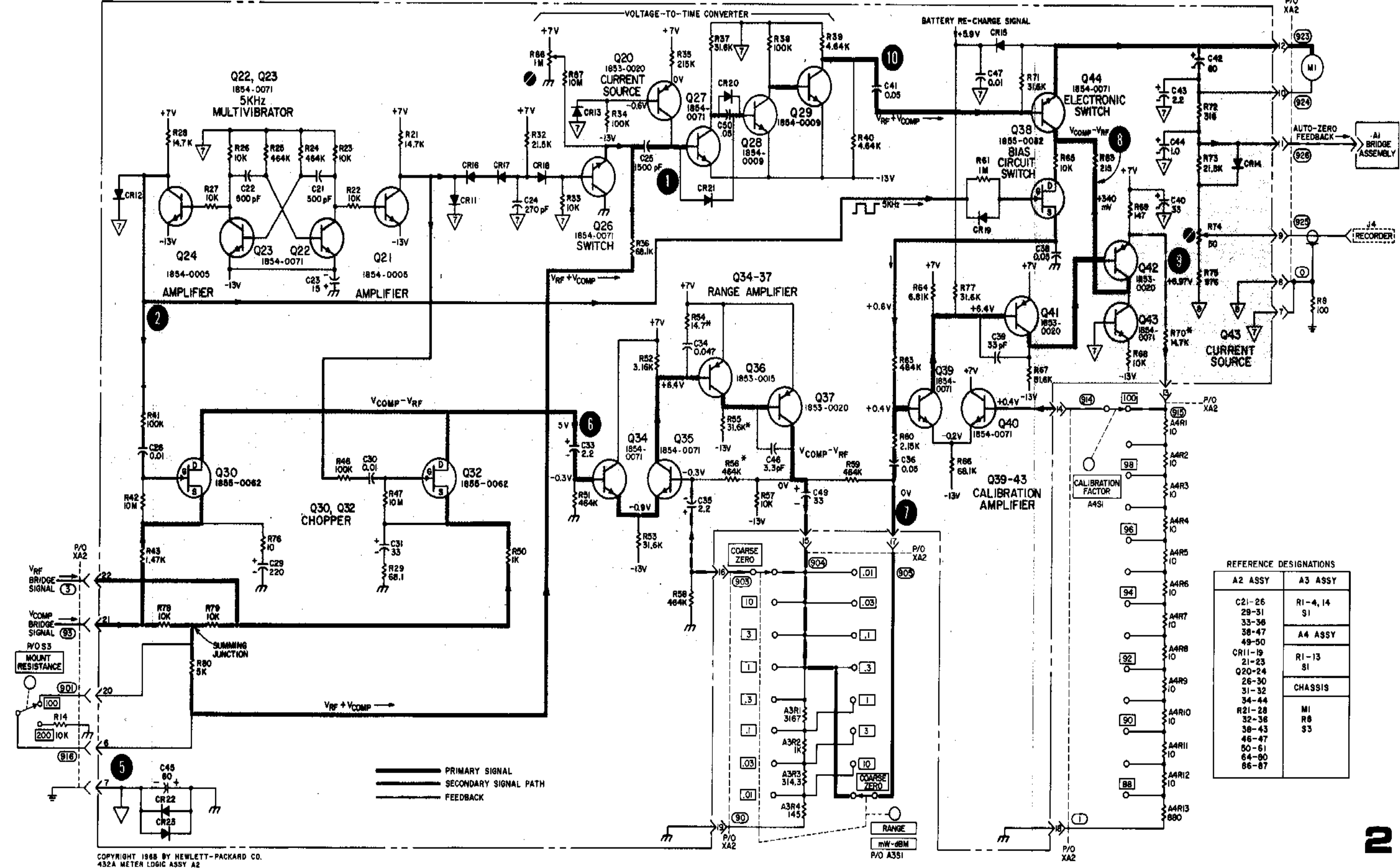

Figure 7-12. Meter Logic Schematic

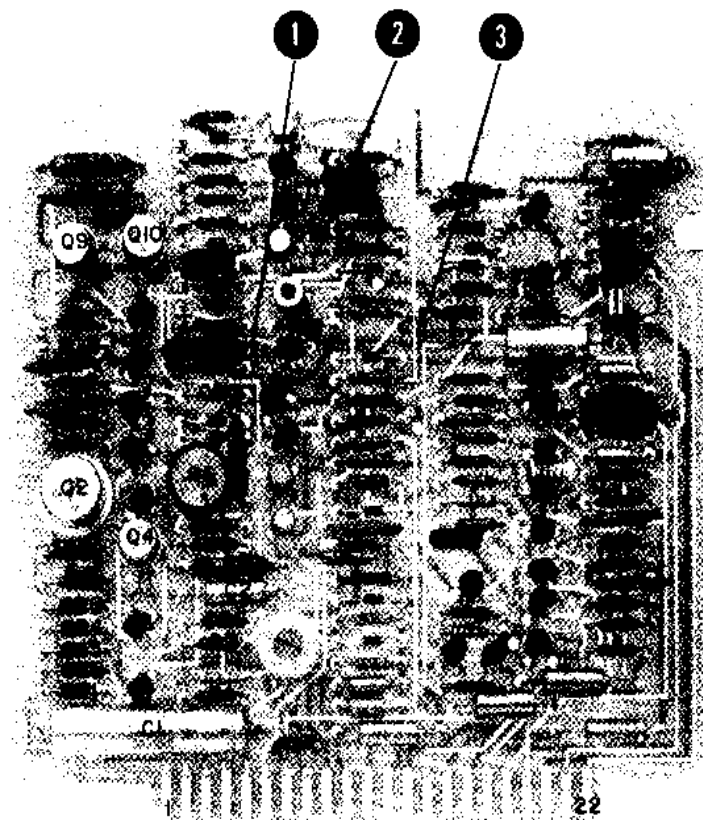

Figure 7-13. A2 Meter Logic Assembly, Power Supply Component Locations

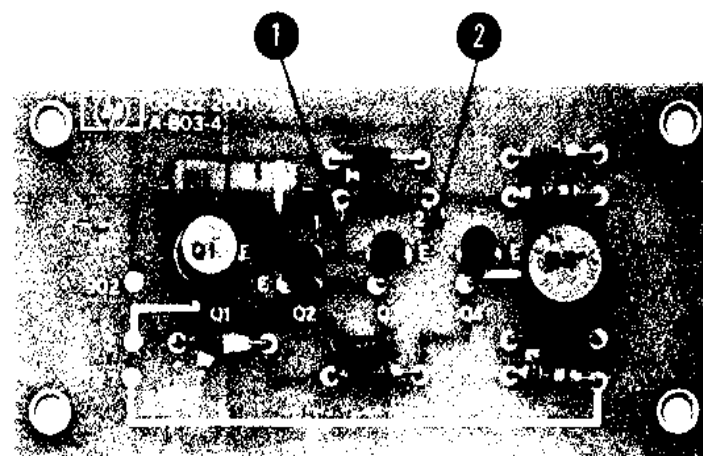

Figure 7-14. A7 Battery Charging Circuit (Option 01), Component Locations

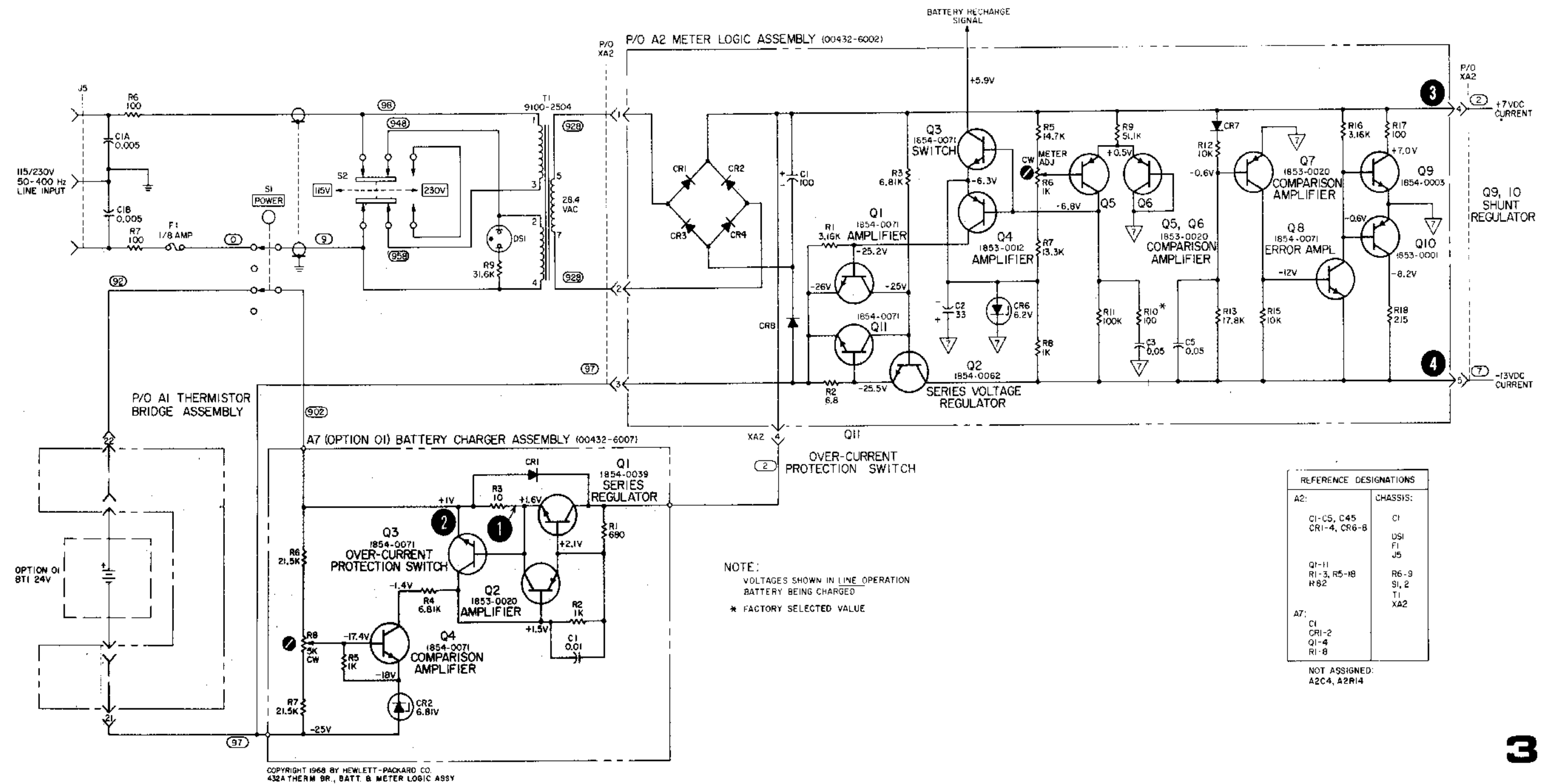

Figure 7-15. Power Supply Schematic

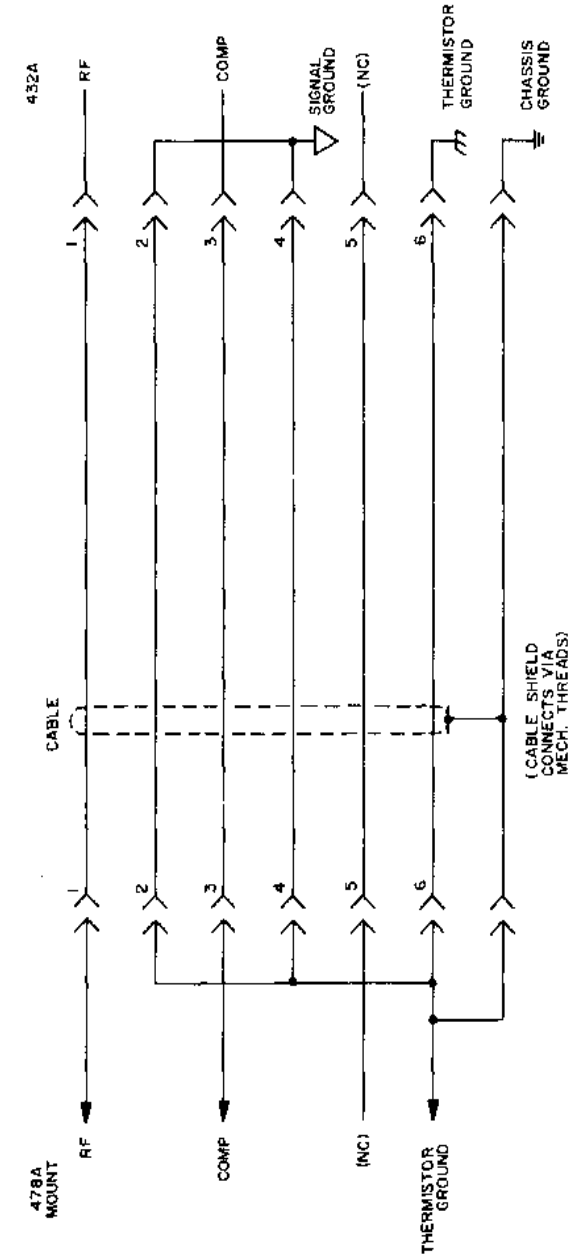
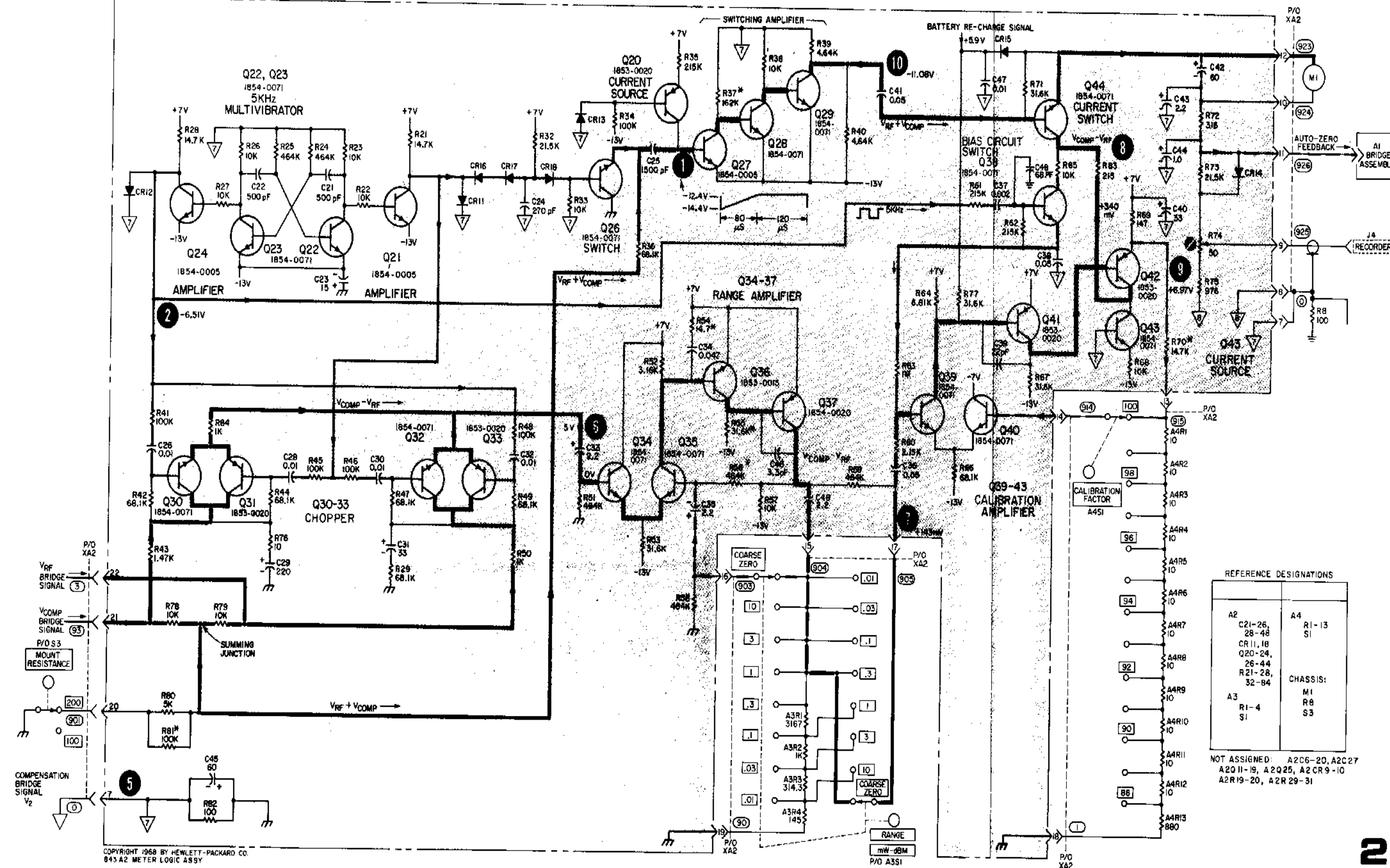

Figure 7-16. Thermistor Cable Wiring Diagram



COPYRIGHT 1968 BY HEWLETT-PACKARD CO.
843 A2 METER LOGIC ASSY

REFERENCE DESIGNATIONS

A2 C21-26, 28-48 CR11, 18 Q20-24, 26-44 R21-28, 32-84	A4 R1-13 S1
A3 R1-4 S1	CHASSIS: M1 R8 S3

NOT ASSIGNED: A2C6-20, A2C27
A2011-19, A2Q25, A2CR9-10
A2R19-20, A2R29-31

Figure A1-3. Meter Logic Schematic

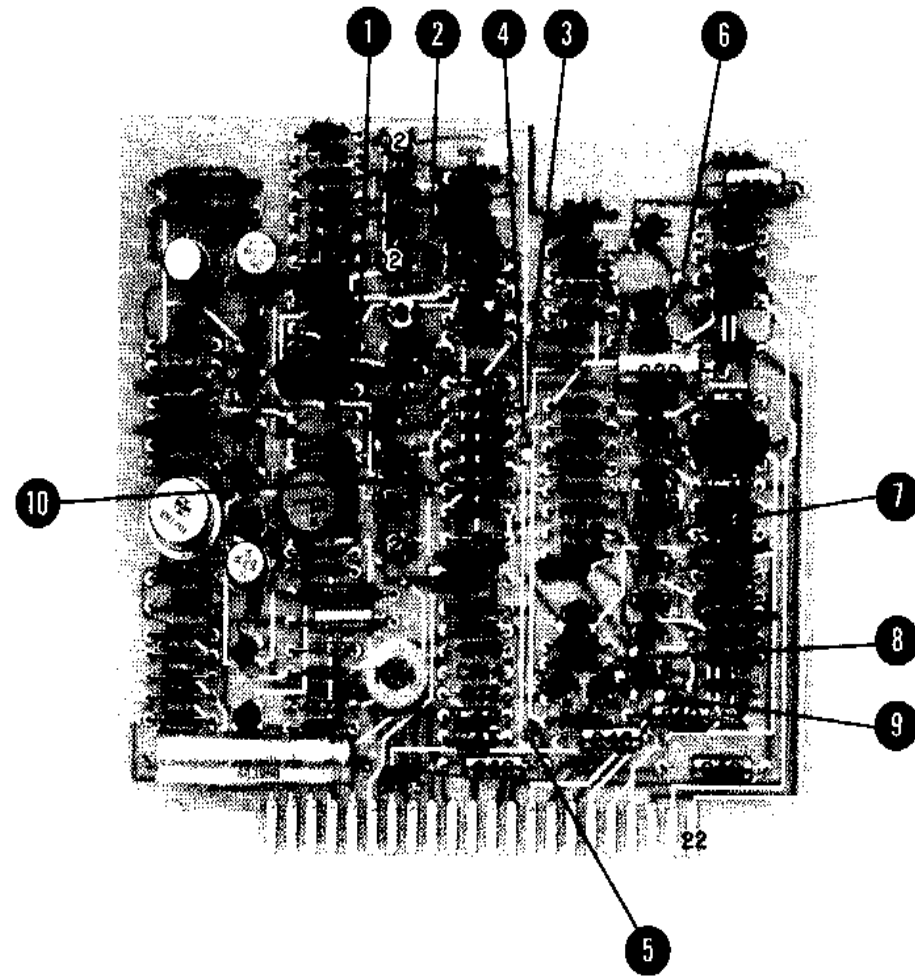

Figure 7-11. A2 Meter Logic Assembly Component Locations

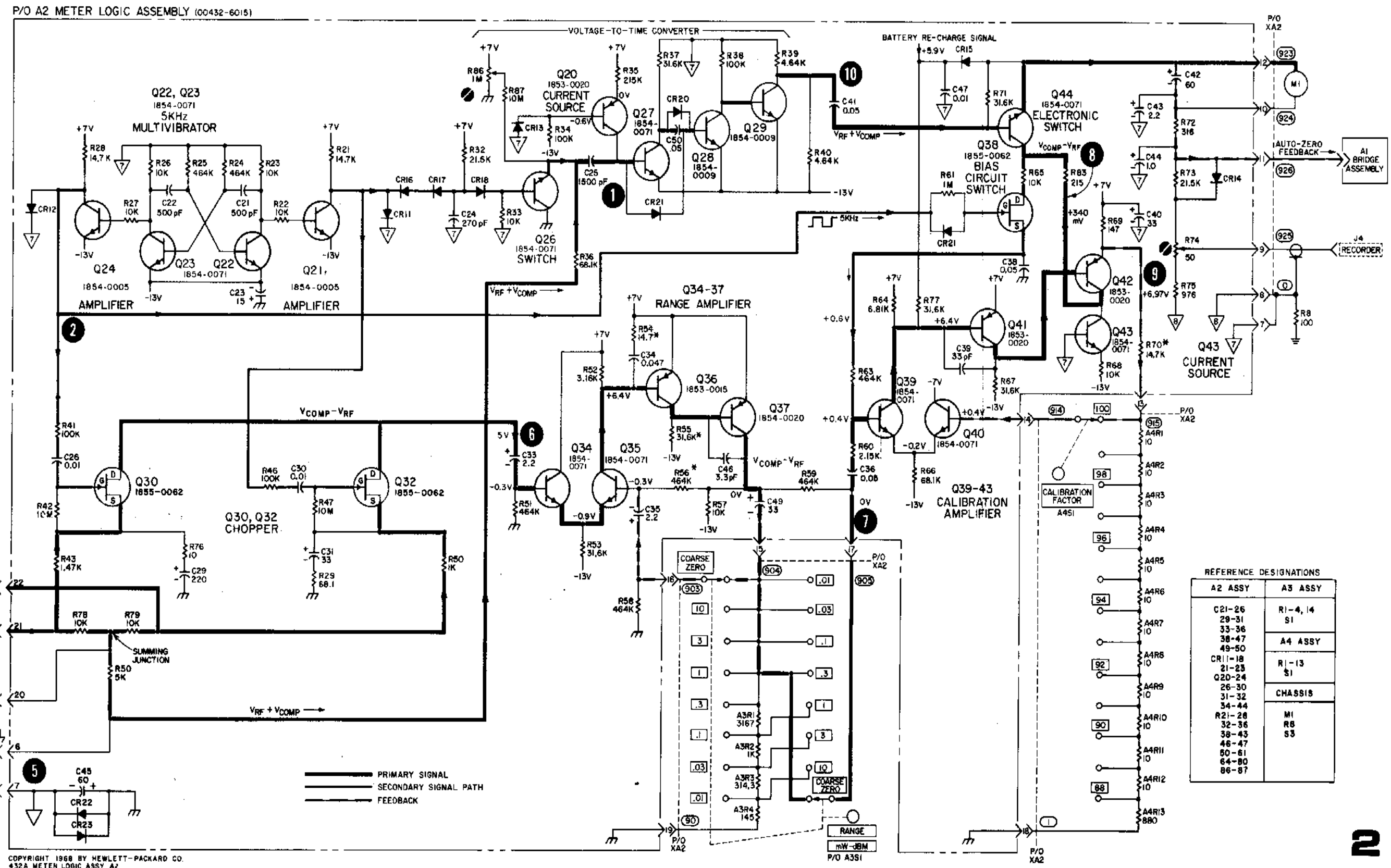

Figure 7-12. Meter Logic Schematic

